

# GATES INDUSTRIAL FLUID POWER

CATALOG NO.	50176
EDITION	2024
SUPERSEDES	50176 (2019)

## HYDRAULIC TUBE FITTINGS CATALOGUE 2024



**DRIVEN BY POSSIBILITY™**



OUR VISION

**“CONTINUALLY PUSH  
THE BOUNDARIES OF  
MATERIALS SCIENCE TO  
ADVANCE THE WAY THE  
WORLD MOVES.”**



## GATES. DRIVEN BY POSSIBILITY.

Gates Corporation is a leading manufacturer of application-specific fluid power and power transmission solutions. We serve customers across industries, bringing relentless innovation, and **uncompromising quality** to every product we make. Our reputation is **built on over a century of experience**, but everything we do is geared towards powering the future.

## ENGINEERED TO EXCEED EXPECTATIONS.

Change is a part of the Gates DNA. We never stand still, but are always looking for ways to meet emerging challenges head-on with solutions that accelerate our partners' growth and development. That's why **thousands of industrial facilities and automotive manufacturers around the world choose Gates** hose and hydraulic systems, equipment, and accessories to power their most demanding fluid power applications.

## PORT-TO-PORT HYDRAULIC SOLUTIONS.

With patented technologies designed to perform in extreme conditions, Gates is committed to create **fluid power system solutions for your specific working needs**. All our hydraulic products are specifically designed, tested and validated together to produce pre-tested and validated combinations that perform beyond any international standard. This kind of easy self-assembly is known as the **Gates Integrated System approach**, saving you time and effort. That is why Gates is your total fluid power solution.

## INNOVATION FUELED BY MATERIALS SCIENCE.

We don't rest on our rich heritage of innovation. We leverage it to inspire solutions that will power the next hundred years. We invest continually in R&D and technology, so our products not only outperform industry standards; they exceed our customers' demanding expectations. The **Zinc Nickel coating on our Gates Hydraulic Tube Fittings** protects against red rust for over 1200 hours (acc. to **ISO 9227**). It provides a significantly better surface protection than standard chrome VI free surface finishing materials, whilst easily reaching protection **class K5** of the **VDMA24576 standard**.

## COMMITTED TO YOUR BUSINESS.

With Gates, you benefit from the strength and expertise of a **global manufacturer**, the innovative and reliable aspects of **German engineering**, and the convenience of a nearby distribution network, local product support and useful online tools. A winning combination by any standards.

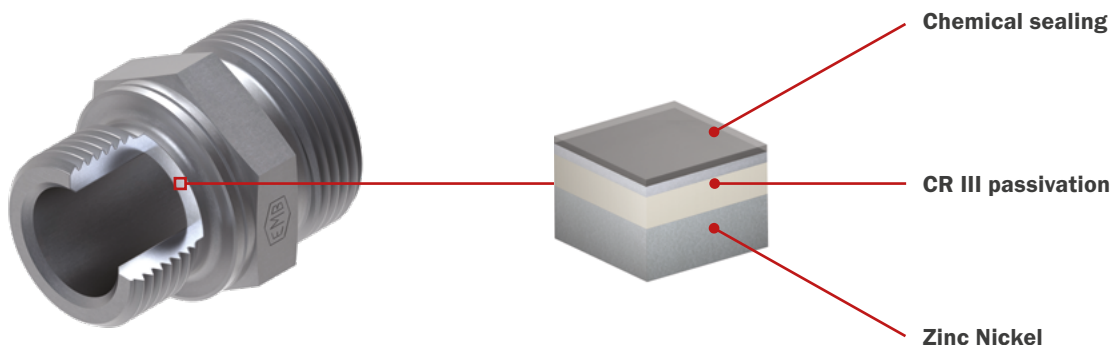

# CONTENTS & TUBE FITTINGS SELECTION TABLE



## CONTENTS

1. PIPE SCREW JOINTS.....	12
2. TUBE FITTINGS.....	46
3. PIPE CONNECTIONS.....	95
4. VALVES.....	106
5. SINGLE PARTS.....	115
6. WELDING NIPPLE-PIPE SCREW JOINTS.....	130
7. FLARE FITTINGS.....	135
8. CONTROL SYSTEM.....	139
9. MACHINERY.....	174
10. ENGINEERING & TECHNICAL DATA.....	189

# CONTENTS & TUBE FITTINGS SELECTION TABLE



## PIPE SCREW JOINTS/SCREW IN SCREW JOINTS/ SCREW JOINT PIPE CONNECTIONS

### A

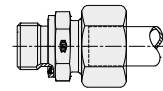
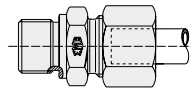
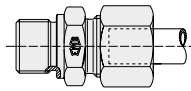
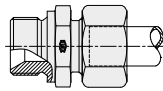
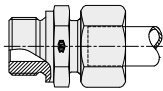

**A Male stud fitting**  
Metric Form A  
p. 13

**A Male stud fitting**  
BSP Form A  
p. 14

**A Male stud fitting**  
BSP  
p. 16

**A Male stud fitting**  
Metric  
p. 18

**A Male stud fitting**  
BSP WD  
p. 19

### A

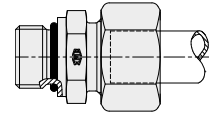
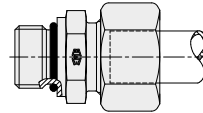
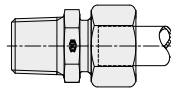
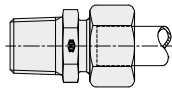
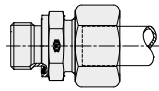

**A Male stud fitting**  
Metric WD  
p. 23

**A Male stud fitting**  
NPT  
p. 21

**A Male stud fitting**  
BSP Taper  
p. 22

**A Male stud fitting**  
Metric O-ring  
p. 23

**A Male stud fitting**  
UNF/UN O-ring  
p. 24

### B C

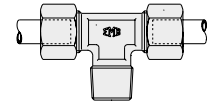
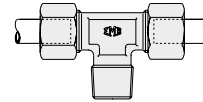
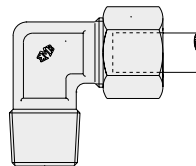
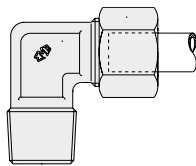
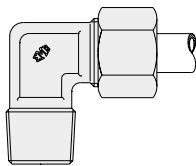

**B Male stud elbow**  
BSP taper  
p. 25

**B Male stud elbow**  
Metric taper  
p. 26

**B Male stud elbow**  
NPT  
p. 27

**C Male stud fitting**  
BSP Taper  
p. 28

**C Male stud fitting**  
Metric Taper  
p. 29

### C D E

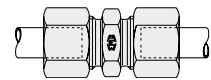
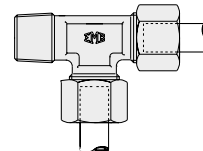
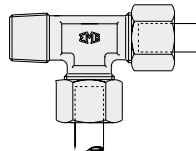
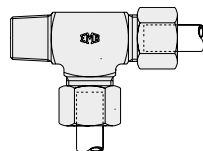
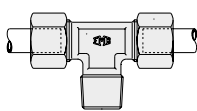

**C Male stud fitting**  
NPT  
p. 30

**D Male stud run tee**  
BSP taper  
p. 31

**D Male stud run tee**  
Metric taper  
p. 32

**D Male stud run tee**  
NPT  
p. 33

**E Straight fittings**  
p. 34

# CONTENTS & TUBE FITTINGS SELECTION TABLE

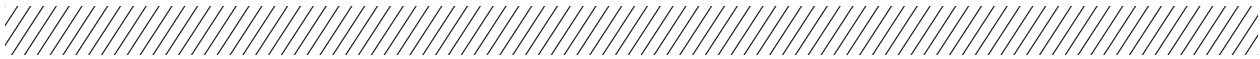

ER	F	G	GR	H
<b>ER Straight reducing fittings</b> p. 35	<b>F Equal elbows</b> p. 36	<b>G Equal tees</b> p. 37	<b>GR Tee reducers</b> p. 38	<b>H Equal crosses</b> p. 40

K	L	N	V	BS
<b>K Straight bulkhead connections</b> p. 41	<b>L Bulkhead elbow connections</b> p. 42	<b>N Welding bulkhead connections</b> p. 43	<b>V Welding bosses</b> p. 44	<b>BS Welding elbows</b> p. 45

## TUBE FITTINGS

### Banjo fitting

SBD				SB
<b>SBD Banjo fitting</b> BSP p. 47	<b>SBD Banjo fitting</b> Metric p. 48	<b>SBD Banjo fitting</b> components BSP DKA p. 49	<b>SBD Banjo fitting</b> components Metric DKA p. 50	<b>SB Banjo fitting</b> choke-free BSP p. 51

SB	SBE			
<b>SB Banjo fitting</b> choke-free Metric p. 52	<b>SBE Banjo fitting high pressure</b> BSP DKA p. 53	<b>SBE Banjo fitting high pressure</b> BSP EDE p. 54	<b>SBE Banjo fitting high pressure</b> BSP KDE p. 55	<b>SBE Banjo fitting high pressure</b> Metric DKA p. 56

# CONTENTS & TUBE FITTINGS SELECTION TABLE



SBE		SGE		
<b>SBE Banjo fitting high pressure Metric EDE</b> p. 57	<b>SBE Banjo fitting high pressure Metric KDE</b> p. 58	<b>SGE T swiveling screw fitting high pressure BSP DKA</b> p. 59	<b>SGE T swiveling screw fitting high pressure BSP EDE</b> p. 60	<b>SGE T swiveling screw fitting high pressure Metric DKA</b> p. 61

## Adjustable fitting

SGE	VB	VC	VD	VBDKO
<b>SGE T swiveling screw fitting high pressure Metric EDE</b> p. 62	<b>VB Adjustable elbow</b> p. 63	<b>VC Adjustable branch tee</b> p. 64	<b>VD Adjustable barrel tee</b> p. 65	<b>VBDKO Adjustable male stud elbow</b> p. 66

## Standpipe fitting

BFDKO	VCDKO	VDDKO	VA/WD	
<b>BFDKO Adjustable 45° elbow</b> p. 67	<b>VCDKO Adjustable equal tee</b> p. 68	<b>VDDKO Adjustable male stud tee-stud barrel</b> p. 69	<b>VA/WD Stud standpipe fitting BSP</b> p. 70	<b>VA/WD Stud standpipe fitting Metric</b> p. 71

VA	VADKO			EDKO
<b>VA Stud standpipe fitting NPT</b> p. 72	<b>VADKO/WD Stud standpipe adaptor BSP</b> p. 73	<b>VADKO/WD Stud standpipe adaptor Metric</b> p. 74	<b>VADKO Stud standpipe adaptor NPT</b> p. 75	<b>EDKO Straight fitting taper</b> p. 76

## Adjustable locknut fitting

EDKOR	BE			
<b>EDKOR Straight reducer fitting taper</b> p. 77	<b>BE Adjustable locknut elbow Metric</b> p. 79	<b>BE Adjustable locknut elbow UNF/UN</b> p. 80	<b>BE Adjustable locknut elbow BSP RR</b> p. 81	<b>BE Adjustable locknut elbow Metric RR</b> p. 82

# CONTENTS & TUBE FITTINGS SELECTION TABLE



BFE				CE
<b>BFE Adjustable 45° locknut elbow Metric</b> p. 83	<b>BFE Adjustable 45° locknut elbow UNF/UN</b> p. 84	<b>BFE Adjustable 45° locknut elbow BSP RR</b> p. 85	<b>BFE Adjustable 45° locknut elbow Metric RR</b> p. 86	<b>CE Adjustable locknut branch tee Metric</b> p. 87

CE			DE	
<b>CE Adjustable locknut branch tee UNF/UN</b> p. 88	<b>CE Adjustable locknut branch tee BSP RR</b> p. 89	<b>CE Adjustable locknut branch tee Metric RR</b> p. 90	<b>DE Adjustable locknut run tee Metric</b> p. 91	<b>DE Adjustable locknut run tee UNF/UN</b> p. 92

DE	
<b>DE Adjustable locknut run tee BSP RR</b> p. 93	<b>DE Adjustable locknut run tee Metric RR</b> p. 94

## PIPE CONNECTION / PRESSURE-GAUGE CONNECTION / CONNECTIONS REDUCER

Gauge fittings		Female stud fittings	
O	VODKO	AI	
<b>O Gauge fitting</b> BSP p. 96	<b>VODKO Gauge fitting</b> Taper p. 97	<b>AI Female stud fitting</b> BSP p. 98	<b>AI Female stud fitting</b> Metric p. 99



# CONTENTS & TUBE FITTINGS SELECTION TABLE

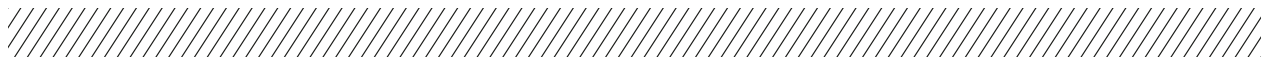

## Gauge fittings

## Female stud fittings

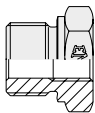
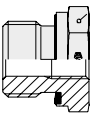
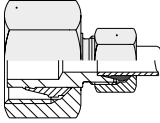
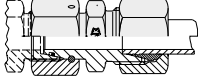
RI	RI/WD	RL/RS	RLDKO/RSDKO
			
RI Reducing adaptor BSP p. 100	RI/WD Reducing adaptor BSP p. 101	RL/RS Reducing connection p. 102-103	RLDKO/RSDKO Reducing connection p. 104-105

## VALVES / NON-RETURN VALVES / SHUT-OFF ELEMENTS

### Non-return valves with cone

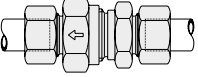
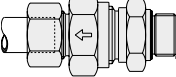
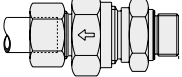
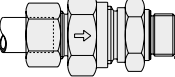
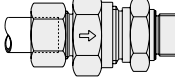
RD	RV		RZ	
				
RD Non-return valves p. 108	RV Non-return valves BSP p. 109	RV Non-return valves Metric p. 110	RZ Non-return valves BSP p. 111	RZ Non-return valves Metric p. 112

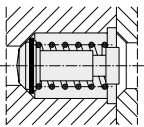
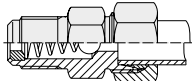
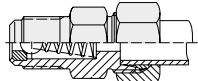

### Ball check valves

RF	RVS	ARVA	ARVV
			
RF Non-return valves p. 113	RVS Inside parts p. 113	ARVA Ball check valves p. 114	ARVV Ball check valves p. 114

## SINGLE PARTS

### Cutting Ring

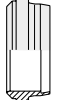
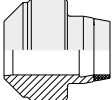
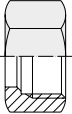
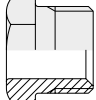
### Nut

DS	DSW	M	UES	GM
				
DS Cutting Ring p. 116	DSW Cutting Ring p. 117	M Fitting nut p. 118	UES Internal fitting nut p. 119	GM Counter nut p. 119

# CONTENTS & TUBE FITTINGS SELECTION TABLE



## Plug

## Sealing Ring

VSCH/WD	VSCHK	STO/O	DKA/DKAD	DKI
VSCH/WD Blanking plug p. 120	VSCHK Standpipe end plug p. 121	STO/O Blanking plug p. 122	DKA/DKAD Sealing Ring p. 123-124	DKI Packing ring p. 125

## Support Sleeve

WD	TR	KDE	EDE	VSH
WD Captive seal p. 125	TR Sealing Ring p. 126	KDE Retaining ring p. 127	EDE Retaining ring with captive seal p. 128	VSH Support Sleeve p. 129

## WELDING NIPPLE-PIPE SCREW JOINTS

### Welding nipples

### Welding type screw joints

SNO	SNR	SNO-V	SNO-A
SNO Welding nipple p. 131	SNR Welding nipple reducer p. 132	SNO-V Welding type screw joint p. 133	SNO-A Welding type order example p. 134

## FLARE FITTINGS

### Flare connection parts

BAO	SRO	BMO	ABO-A
BAO Flare adaptor p. 136	SRO Support ring p. 137	BMO Nut p. 137	Flaring type order example p. 138







# CONTENTS & TUBE FITTINGS SELECTION TABLE

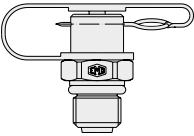
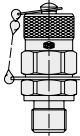
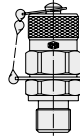
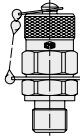

## CONTROL SYSTEM

### Test Fittings

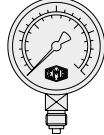
### Accessories

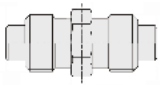
CST	CSH	CSS	CSHK	CST
				
<b>CST Test fitting</b> 400 bar p. 140-143	<b>CSH Test fitting</b> 630 bar p. 144-150	<b>CSS Test fitting</b> 630 bar p. 151-157	<b>CSHK Test fitting</b> 630 bar p. 158-161	<b>CST Pressure test kit</b> p. 162
CSH	CSS	CMM	VO	CS
				
<b>CSH Pressure test kit</b> p. 162	<b>CSS Pressure test kit</b> p. 162	<b>CMM Pressure gauge</b> p. 163	<b>VO Adjustable gauge fitting</b> p. 163	<b>CS Hose connector</b> p. 164



**DRIVEN BY POSSIBILITY™**

# **1. PIPE SCREW JOINTS**

# PIPE SCREW JOINTS

A MALE STUD FITTINGS



## A MALE STUD FITTING METRIC FORM A

Metric parallel.

Sealing by additional sealing element,

e.g. sealing ring according to DIN 7603

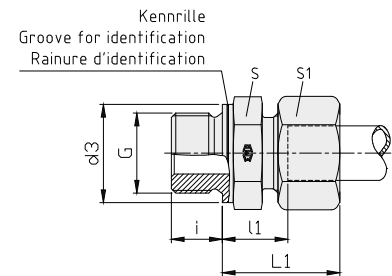

description	pipe OD	PN series	S	S1	L1	l1	d3	i	G	kg / 100 pcs
DS-A 6-ML/FormA	6	L 250	14	14	23.5	8.5	14	8	M 10 x 1	2.83
DS-A 8-ML/FormA	8		17	17	25	10	17	12	M 12 x 1,5	4.39
DS-A 10-ML/FormA	10		19	19	26	11	19	12	M 14 x 1,5	5.65
DS-A 12-ML/FormA	12		22	22	27	12.5	21	12	M 16 x 1,5	7.61
DS-A 15-ML/FormA	15		24	27	28.5	13.5	23	12	M 18 x 1,5	10.67
DS-A 18-ML/FormA	18		27	32	31	14.5	27	14	M 22 x 1,5	15.68
DS-A 22-ML/FormA	22		32	36	33	32.5	31	16	M 26 x 1,5	20.98
DS-A 28-ML/FormA	28	L 160	41	41	34	17.5	39	18	M 33 x 2	29.73
DS-A 35-ML/FormA	35		50	50	39	17.5	49	20	M 42 x 2	47.94
DS-A 42-ML/FormA	42		55	60	42	19	55	22	M 48 x 2	65.17
DS-A 6-MS/FormA	6	S 250	17	17	28	13	17	12	M 12 x 1,5	5.45
DS-A 8-MS/FormA	8		19	19	30	15	19	12	M 14 x 1,5	7.16
DS-A 10-MS/FormA	10		22	22	31.5	15.5	21	12	M 16 x 1,5	9.64
DS-A 12-MS/FormA	12		24	24	33	17	23	12	M 18 x 1,5	11.89
DS-A 14-MS/FormA	14		27	27	36,5	19	25	14	M 20 x 1,5	16.42
DS-A 16-MS/FormA	16		27	30	37	18.5	27	14	M 22 x 1,5	18.25
DS-A 20-MS/FormA	20	S 160	32	36	42	20.5	32	16	M 27 x 2	28.83
DS-A 25-MS/FormA	25		41	46	47	23	39	18	M 33 x 2	52.22
DS-A 30-MS/FormA	30	S 100	50	50	50	23.5	49	20	M 42 x 2	71.44
DS-A 38-MS/FormA	38		55	60	26,5	26	55	22	M 48 x 2	98.98

# PIPE SCREW JOINTS

A MALE STUD FITTINGS



## A MALE STUD FITTING BSP FORM A

BSP parallel.

Sealing by additional sealing element,  
e.g. sealing ring according to DIN 7603

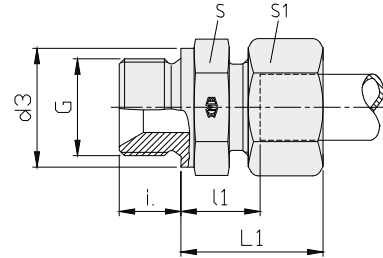

description	pipe OD	PN series	S	S1	L1	l1	d3	i	G	kg / 100 pcs
DS-A 6-L/R 1/2"/FormA/60°	6	L 250	27	14	27	12	26	14	G 1/2" A	8.50
DS-A 6-L/R 1/4"/FormA/60°	6		19	14	25	10	18	12	G 1/4" A	4.29
DS-A 6-RL/FormA/60°	6		14	14	23.5	8.5	14	8	G 1/8" A	2.78
DS-A 8-L/R 1/8"/FormA/60°	8		14	17	23.5	8.5	14	8	G 1/8" A	3.52
DS-A 8-L/R 3/8"/FormA/60°	8		22	17	26.5	11.5	22	12	G 3/8" A	6.40
DS-A 8-RL/FormA/60°	8		19	17	25	10	18	12	G 1/4" A	4.82
DS-A 10-L/R 1/2"/FormA/60°	10		27	19	28	13	26	14	G 1/2" A	9.50
DS-A 10-L/R 3/8"/FormA/60°	10		22	19	27.5	12.5	22	12	G 3/8" A	7.00
DS-A 10-RL/FormA/60°	10		19	19	26	11	18	12	G 1/4" A	5.52
DS-A 12-L/R 1/2"/FormA/60°	12		27	22	28	13	26	14	G 1/2" A	10.36
DS-A 12-L/R 1/4"/FormA/60°	12		19	22	26.5	12	18	12	G 1/4" A	6.68
DS-A 12-L/R 3/4"/FormA/60°	12		32	22	29	14	32	16	G 3/4" A	14.82
DS-A 12-RL/FormA/60°	12		22	22	27.5	12.5	22	12	G 3/8" A	7.68
DS-A 15-L/R 3/4"/FormA/60°	15		32	27	31	15	32	16	G 3/4" A	16.76
DS-A 15-L/R 3/8"/FormA/60°	15		24	27	28.5	13.5	22	12	G 3/8" A	10.77
DS-A 15-RL/FormA/60°	15		27	27	29	14	26	14	G 1/2" A	12.56
DS-A 18-L/R 3/4"/FormA/60°	18		32	32	31	14.5	32	16	G 3/4" A	18.84
DS-A 18-L/R 3/8"/FormA/60°	18		27	32	30.5	14	22	12	G 3/8" A	14.43
DS-A 18-RL/FormA/60°	18	27	32	31	14.5	26	14	G 1/2" A	15.05	
DS-A 22-L/R 1"/FormA/60°	22	41	36	33	17.5	39	18	G 1" A	29.57	
DS-A 22-L/R 1/2"/FormA/60°	22	32	36	33	16.5	26	14	G 1/2" A	19.63	
DS-A 22-RL/FormA/60°	22	32	36	33	16.5	32	16	G 3/4" A	21.00	
DS-A 28-L/R 1 1/4"/FormA/60°	28	50	41	35	26	49	20	G 1 1/4" A	42.97	
DS-A 28-L/R 1/2"/FormA/60°	28	41	41	34	17.5	26	14	G 1/2" A	25.08	
DS-A 28-L/R 3/4"/FormA/60°	28	41	41	34	17.5	32	16	G 3/4" A	27.08	
DS-A 28-RL/FormA/60°	28	41	41	34	17.5	39	18	G 1" A	30.24	
DS-A 35-L/R 1"/FormA/60°	35	46	50	39	17.5	39	18	G 1" A	41.35	
DS-A 35-RL/FormA/60°	35	50	50	39	17.5	49	20	G 1 1/4" A	46.90	
DS-A 42-L/R 1 1/4"/FormA/60°	42	55	60	42	19	49	20	G 1 1/4" A	62.32	
DS-A 42-RL/FormA/60°	42	55	60	42	19	55	22	G 1 1/2" A	63.82	

# PIPE SCREW JOINTS

A MALE STUD FITTINGS (CONTINUED)



description	pipe OD	PN series	S	S1	L1	l1	d3	i	G	kg / 100 pcs
DS-A 6-RS/FormA/60°	6	S 250	19	17	28	13	18	12	G 1/4" A	5.88
DS-A 6-S/R 1/8"/FormA/60°	6		14	17	27.5	12.5	14	8	G 1/8" A	4.42
DS-A 6-S/R 3/8"/FormA/60°	6		22	17	32.5	17.5	22	12	G 3/8" A	8.48
DS-A 8-RS/FormA/60°	8		19	19	30	8	18	12	G 1/4" A	6.87
DS-A 8-S/R 1/2"/FormA/60°	8		27	19	33	18	26	14	G 1/2" A	12.33
DS-A 8-S/R 1/8"/FormA/60°	8		17	19	30	15	14	8	G 1/8" A	5.90
DS-A 8-S/R 3/8"/FormA/60°	8		22	19	30	16	22	12	G 3/8" A	8.53
DS-A 10-RS/FormA/60°	10		22	22	30.5	15	22	12	G 3/8" A	9.50
DS-A 10-S/R 1/2"/FormA/60°	10		27	22	34	17.5	26	14	G 1/2" A	13.42
DS-A 10-S/R 1/4"/FormA/60°	10		19	22	28	12.5	18	12	G 1/4" A	7.93
DS-A 12-RS/FormA/60°	12		22	24	33.5	17	22	12	G 3/8" A	10.71
DS-A 12-S/R 1/2"/FormA/60°	12		27	24	34	17.5	26	14	G 1/2" A	14.04
DS-A 12-S/R 1/4"/FormA/60°	12		22	24	33.5	17	18	12	G 1/4" A	10.55
DS-A 12-S/R 3/4"/FormA/60°	12		32	24	36	19.5	32	16	G 3/4" A	19.95
DS-A 14-RS/FormA/60°	14		27	27	37	19	26	14	G 1/2" A	16.37
DS-A 14-S/R 3/8"/FormA/60°	14		24	27	36.5	18.5	22	12	G 3/8" A	14.21
DS-A 16-RS/FormA/60°	16		27	30	37	18.5	26	14	G 1/2" A	17.50
DS-A 16-S/R 3/4"/FormA/60°	16		32	30	39	20.5	32	16	G 3/4" A	23.43
DS-A 16-S/R 3/8"/FormA/60°	16		27	30	36.5	18	22	12	G 3/8" A	16.64
DS-A 20-RS/FormA/60°	20		32	36	42	20.5	32	16	G 3/4" A	28.14
DS-A 20-S/R 1"/FormA/60°	20	41	36	44	22.5	39	18	G 1" A	39.84	
DS-A 20-S/R 1/2"/FormA/60°	20	32	36	42	20.5	26	14	G 1/2" A	26.68	
DS-A 25-RS/FormA/60°	25	S 160	41	46	47	23	39	18	G 1" A	51.36
DS-A 25-S/R 1 1/4"/FormA/60°	25		50	46	50	26	49	20	G 1 1/4" A	70.91
DS-A 25-S/R 1/2"/Form A/60°	25		41	46	50	23	26	14	G 1/2" A	47.23
DS-A 25-S/R 3/4"/FormA/60°	25		41	46	47	23	32	16	G 3/4" A	48.52
DS-A 30-RS/FormA/60°	30	S 100	50	50	50	23.5	49	20	G 1 1/4" A	69.04
DS-A 30-S/R 1"/FormA/60°	30		46	50	50	23.5	39	18	G 1" A	60.58
DS-A 30-S/R 3/4"/FormA/60°	30		46	50	50	23.5	32	16	G 3/4" A	57.79
DS-A 38-RS/FormA/60°	38		55	60	57	26	55	22	G 1 1/2" A	96.38
DS-A 38-S/R 1"/FormA/60°	38	55	60	57	26	39	18	G 1" A	90.50	
DS-A 38-S/R 1 1/4"/FormA/60°	38	55	60	57	26	49	20	G 1 1/4" A	94.87	

# PIPE SCREW JOINTS

A MALE STUD FITTINGS



## A MALE STUD FITTING BSP

Series LL, BSP taper.

Series L+S, BSP parallel, form B.

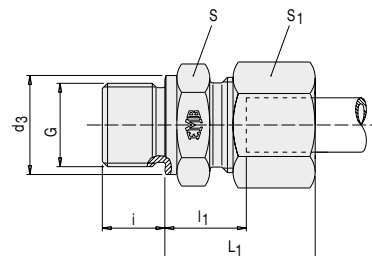

description	pipe OD	PN series	S	S <sub>1</sub>	L <sub>1</sub>	l <sub>1</sub>	d <sub>3</sub>	i	G	kg / 100 pcs
A 4-RLL	4	LL 100 (400)	11	10	26.0	16.0	-	8	R 1/8" K taper	1.4
A 6-RLL	6	LL PN 100 (400)	11	12	26.0	14.5	-	8	R 1/8" K taper	1.6
A 8-RLL	8		12	14	28.0	16.5	-	8	R 1/8" K taper	1.8
DS-A 6-RL	6		14	14	23.0	8.5	14	8	G 1/8" A	2.5
DS-A 6-L/R 1/4"	6	L PN 400 (1600)	19	14	25.0	10.0	18	12	G 1/4" A	3.5
DS-A 6-L/R 3/8"	6		22	14	26.0	11.5	22	12	G 3/8" A	5.6
DS-A 6-L/R 1/2"	6		27	14	27.0	12.0	26	14	G 1/2" A	7.3
DS-A 8-RL	8		19	17	25.0	10.0	18	12	G 1/4" A	4.5
DS-A 8-L/R 1/8"	8		14	17	24.0	9.5	14	8	G 1/8" A	3.1
DS-A 8-L/R 3/8"	8		22	17	26.0	11.5	22	12	G 3/8" A	6.0
DS-A 8-L/R 1/2"	8		27	17	27.0	12.0	26	14	G 1/2" A	9.0
DS-A 10-RL	10		19	19	26.0	11.0	18	12	G 1/4" A	4.7
DS-A 10-L/R 3/8"	10		22	19	27.0	12.5	22	12	G 3/8" A	6.2
DS-A 10-L/R 1/2"	10		27	19	28.0	13.0	26	14	G 1/2" A	9.2
DS-A 12-RL	12		22	22	27.0	12.5	22	12	G 3/8" A	7.0
DS-A 12-L/R 1/4"	12		19	22	27.0	12.0	18	12	G 1/4" A	5.8
DS-A 12-L/R 1/2"	12		27	22	28.0	13.0	26	14	G 1/2" A	9.4
DS-A 12-L/R 3/4"	12		32	22	29.0	14.0	32	16	G 3/4" A	14.7
DS-A 15-RL	15		27	27	29.0	14.0	26	14	G 1/2" A	11.5
DS-A 15-L/R 3/8"	15		24	27	29.0	13.5	22	12	G 3/8" A	9.7
DS-A 15-L/R 3/4"	15		32	27	30.0	15.0	32	16	G 3/4" A	16.1
DS-A 18-RL	18		27	32	31.0	14.5	26	14	G 1/2" A	13.2
DS-A 18-L/R 3/8"	18	27	32	29.5	14.0	22	12	G 3/8" A	13.3	
DS-A 18-L/R 3/4"	18	32	32	30.0	14.5	32	16	G 3/4" A	17.3	

L<sub>1</sub> = approximate length with nut tightened

Please see "Engineering and technical data - Selecting the correct tube fitting" for more information on pressure.



# PIPE SCREW JOINTS

A MALE STUD FITTINGS (CONTINUED)



description	pipe OD	PN/PB series	S	S <sub>1</sub>	L <sub>1</sub>	l <sub>1</sub>	d <sub>3</sub>	i	G	kg / 100 pcs
DS-A 22-RL	22	L PN 250 (1000)	32	36	33	16.5	32	16	G 3/4" A	18.5
DS-A 22-L/R 1/2"	22		32	36	47	26.5	26	14	G 1/2" A	17.7
DS-A 28-RL	28		41	41	34	17.5	39	18	G 1" A	25.9
DS-A 28-L/R 3/4"	28	L PB 250 (625)	41	41	34	17.5	32	16	G 3/4" A	25.6
DS-A 35-RL	35		50	50	39	17.5	49	20	G 1 1/4" A	42.2
DS-A 35-L/R 1"	35		46	50	39	17.5	39	18	G 1" A	37.8
DS-A 42-RL	42	S PB 630 (1575)	55	60	42	19.0	55	22	G 1 1/2" A	56.9
DS-A 6-RS	6		19	17	28	13.0	18	12	G 1/4" A	5.0
DS-A 6-S/R 1/2"	6		27	17	33	18.0	26	14	G 1/2" A	10.8
DS-A 8-RS	8		19	19	30	15.0	18	12	G 1/4" A	5.5
DS-A 8-S/R 3/8"	8		22	19	30	15.5	22	12	G 3/8" A	8.0
DS-A 10-RS	10		22	22	31	15.0	22	12	G 3/8" A	8.8
DS-A 10-S/R 1/4"	10		19	22	31	14.5	18	12	G 1/4" A	7.5
DS-A 10-S/R 1/2"	10		27	22	34	17.5	26	14	G 1/2" A	12.9
DS-A 12-RS	12		22	24	33	17.0	22	12	G 3/8" A	10.0
DS-A 12-S/R 1/4"	12		22	24	33	16.5	18	12	G 1/4" A	9.3
DS-A 12-S/R 1/2"	12		27	24	34	17.5	26	14	G 1/2" A	13.3
DS-A 14-RS	14		27	27	37	19.0	26	14	G 1/2" A	14.8
DS-A 14-S/R 3/8"	14		24	27	36	18.5	22	12	G 3/8" A	12.8
DS-A 16-RS	16		27	30	37	18.5	26	14	G 1/2" A	16.1
DS-A 16-S/R 3/8"	16		27	30	36	18.0	22	12	G 3/8" A	15.3
DS-A 16-S/R 3/4"	16		32	30	39	20.5	32	16	G 3/4" A	22.6
DS-A 20-RS	20		32	36	42	20.5	32	16	G 3/4" A	25.3
DS-A 20-S/R 1/2"	20		32	36	42	20.5	26	14	G 1/2" A	24.3
DS-A 25-RS	25		41	46	47	23.0	39	18	G 1" A	48.7
DS-A 25-S/R 3/4"	25		41	46	47	23.0	32	16	G 3/4" A	46.5
DS-A 30-RS	30	50	50	50	23.5	49	20	G 1 1/4" A	66.3	
DS-A 30-S/R 1"	30	46	50	50	23.5	39	18	G 1" A	57.8	
DS-A 38-RS	38	55	60	57	26.0	55	22	G 1 1/2" A	90.1	
DS-A 38-S/R 1 1/4"	38	55	60	57	26.0	49	20	G 1 1/4" A	91.9	

L<sub>1</sub> = approximate length with nut tightened

Please see "Engineering and technical data - Selecting the correct tube fitting" for more information on pressure.

# PIPE SCREW JOINTS

A MALE STUD FITTINGS



## A MALE STUD FITTING METRIC

Series LL, metric taper.

Series L+S, metric parallel, form B.

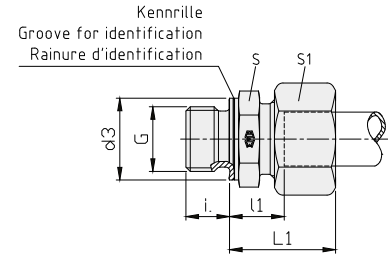

description	pipe OD	PN/PB series	S	S <sub>1</sub>	L <sub>1</sub>	l <sub>1</sub>	d <sub>3</sub>	i	G	kg / 100 pcs
A 4-MLL	4	LL PN 100 (400)	10	10	25	16.0	-	8	M 8 x 1 K	1.4
A 4-LL/M 6 x 1	4		9	10	26	16.0	-	8	M 6 x 1 K	0.9
A 6-MLL	6		11	12	25	14.5	-	8	M 10 x 1 K	1.6
A 8-MLL	8		12	14	27	16.5	-	8	M 10 x 1 K	1.8
DS-A 6-ML	6	L PN 400 (1600)	14	14	23	8.5	14	8	M 10 x 1	2.5
DS-A 8-ML	8		17	17	25	10.0	17	12	M 12 x 1.5	4.0
DS-A 8-L/M 18 x 1.5	8		24	17	26	11.5	23	12	M 18 x 1.5	6.7
DS-A 10-ML	10		19	19	26	11.0	19	12	M 14 x 1.5	4.9
DS-A 10-L/M 16 x 1.5	10		22	19	27	12.0	21	12	M 16 x 1.5	6.0
DS-A 10-L/M 18 x 1.5	10		24	19	27	12.5	23	12	M 18 x 1.5	7.0
DS-A 10-L/M 22 x 1.5	10		27	19	29	14.0	27	14	M 22 x 1.5	9.2
DS-A 12-ML	12		22	22	27	12.5	21	12	M 16 x 1.5	6.8
DS-A 12-L/M 14 x 1.5	12		19	22	26	11.0	19	12	M 14 x 1.5	5.7
DS-A 12-L/M 18 x 1.5	12		24	22	27	12.5	23	12	M 18 x 1.5	7.4
DS-A 12-L/M 22 x 1.5	12		27	22	29	14.0	27	14	M 22 x 1.5	10.3
DS-A 15-ML	15		24	27	29	13.5	23	12	M 18 x 1.5	9.5
DS-A 15-L/M 16 x 1.5	15		24	27	28	13.0	21	12	M 16 x 1.5	9.4
DS-A 15-L/M 22 x 1.5	15		27	27	30	15.0	27	14	M 22 x 1.5	12.1
DS-A 18-ML	18		27	32	31	14.5	27	14	M 22 x 1.5	13.7
DS-A 18-L/M 18 x 1.5	18		27	32	30	14.0	23	12	M 18 x 1.5	13.2
DS-A 22-ML	22	L PN 250 (1000)	32	36	33	16.5	31	16	M 26 x 1.5	18.8
DS-A 22-L/M 22 x 1.5	22		32	36	33	16.5	27	14	M 22 x 1.5	17.8
DS-A 28-ML	28	L PB 250 (625)	41	41	34	17.5	39	18	M 33 x 2	25.8
DS-A 35-ML	35		50	50	39	17.5	49	20	M 42 x 2	42.0
DS-A 42-ML	42		55	60	42	19.0	55	22	M 48 x 2	57.5
DS-A 6-MS	6		17	17	28	13.0	17	12	M 12 x 1.5	4.7
DS-A 8-MS	8	S PB 630*	19	19	30	15.0	19	12	M 14 x 1.5	6.5
DS-A 10-MS	10		22	22	31	15.0	21	12	M 16 x 1.5	8.6
DS-A 12-MS	12		24	24	33	17.0	23	12	M 18 x 1.5	10.9
DS-A 12-S/M 22 x 1.5	12		27	24	34	17.5	27	14	M 22 x 1.5	13.0
DS-A 14-MS	14		27	27	37	19.0	25	14	M 20 x 1.5	14.8
DS-A 16-MS	16		27	30	37	18.5	27	14	M 22 x 1.5	16.6
DS-A 16-S/M 18 x 1.5	16		27	30	36	18.0	23	12	M 18 x 1.5	15.7
DS-A 20-MS	20		S PB 400 (1000)	32	36	42	20.5	32	16	M 27 x 2
DS-A 25-MS	25	41		46	47	23.0	39	18	M 33 x 2	46.5
DS-A 30-MS	30	S PB 250 (625)	50	50	50	23.5	49	20	M 42 x 2	64.4
DS-A 38-MS	38		55	60	57	26.0	55	22	M 48 x 2	87.3

L<sub>1</sub> = approximate length with nut tightened

Please see "Engineering and technical data - Selecting the correct tube fitting" for more information on pressure.

# PIPE SCREW JOINTS

A MALE STUD FITTINGS



## A MALE STUD FITTING BSP WD

BSP parallel.

Captive seal NBR (e.g. Perbunan),  
FKM (e.g. Viton) upon request.

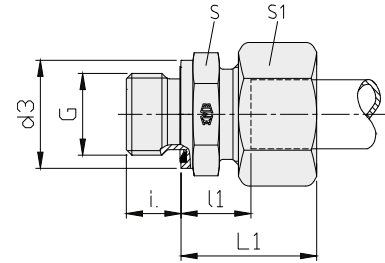

description	pipe OD	PN series	S	S <sub>1</sub>	L <sub>1</sub>	l <sub>1</sub>	d <sub>3</sub>	i	G	kg / 100 pcs
DS-A 6-RL/WD	6	L 500 (2200)	14	14	23	8.5	14	8	G 1/8" A	2.5
DS-A 6-L/R 1/4"/WD	6		19	14	25	10.0	19	12	G 1/4" A	3.9
DS-A 8-RL/WD	8		19	17	25	10.0	19	12	G 1/4" A	4.5
DS-A 8-L/R 1/8"/WD	8		14	17	23	8.5	14	8	G 1/8" A	2.9
DS-A 8-L/R 3/8"/WD	8		22	17	26	11.5	22	12	G 3/8" A	5.9
DS-A 10-RL/WD	10		19	19	26	11.0	19	12	G 1/4" A	4.7
DS-A 10-L/R 3/8"/WD	10	22	19	27	12.5	22	12	G 3/8" A	6.2	
DS-A 10-L/R 1/2"/WD	10	27	19	28	13.0	27	14	G 1/2" A	9.2	
DS-A 12-RL/WD	12	22	22	27	12.5	22	12	G 3/8" A	6.9	
DS-A 12-L/R 1/4"/WD	12	19	22	27	12.0	19	12	G 1/4" A	5.8	
DS-A 12-L/R 1/2"/WD	12	27	22	28	13.0	27	14	G 1/2" A	9.4	
DS-A 15-RL/WD	15	L 400 (1700)	27	27	29	14.0	27	14	G 1/2" A	11.5
DS-A 15-L/R 3/8"/WD	15		24	27	29	13.5	22	12	G 3/8" A	9.7
DS-A 18-RL/WD	18		27	32	31	14.5	27	14	G 1/2" A	13.2
DS-A 18-L/R 3/4"/WD	18	32	32	31	14.5	32	16	G 3/4" A	17.4	
DS-A 22-RL/WD	22	L 250 (1100)	32	36	33	16.5	32	16	G 3/4" A	18.5
DS-A 28-RL/WD	28		41	41	34	17.5	40	18	G 1" A	25.9
DS-A 35-RL/WD	35		50	50	39	17.5	50	20	G 1 1/4" A	42.2
DS-A 42-RL/WD	42	55	60	42	19.0	55	22	G 1 1/2" A	56.9	
DS-A 6-RS/WD	6	S 800 (3400)	19	17	28	13.0	19	12	G 1/4" A	5.0
DS-A 8-RS/WD	8		19	19	30	15.0	19	12	G 1/4" A	5.5
DS-A 8-S/R 3/8"/WD	8		22	19	30	15.5	22	12	G 3/8" A	7.8
DS-A 10-RS/WD	10		22	22	31	15.0	22	12	G 3/8" A	8.8
DS-A 10-S/R 1/4"/WD	10		19	22	31	14.5	19	12	G 1/4" A	7.3
DS-A 10-S/R 1/2"/WD	10		27	22	34	17.5	27	14	G 1/2" A	12.9
DS-A 12-RS/WD	12	22	24	33	17.0	22	12	G 3/8" A	10.0	
DS-A 12-S/R 1/4"/WD	12	22	24	33	16.5	19	12	G 1/4" A	9.3	
DS-A 12-S/R 1/2"/WD	12	27	24	34	17.5	27	14	G 1/2" A	13.6	
DS-A 14-RS/WD	14	S 630 (2700)	27	27	37	19.0	27	14	G 1/2" A	14.8
DS-A 16-RS/WD	16		27	30	37	18.5	27	14	G 1/2" A	16.1
DS-A 16-S/R 3/8"/WD	16		27	30	36	18.0	22	12	G 3/8" A	15.2
DS-A 16-S/R 3/4"/WD	16	32	30	39	20.5	27	16	G 3/4" A	22.2	
DS-A 20-RS/WD	20	S 400 (1700)	32	36	42	20.5	32	16	G 3/4" A	25.3
DS-A 25-RS/WD	25		41	46	47	23.0	40	18	G 1" A	46.5
DS-A 25-S/R 1/2"/WD	25		41	46	47	23.0	27	14	G 1/2" A	45.0
DS-A 30-RS/WD	30		50	50	50	23.5	50	20	G 1 1/4" A	63.5
DS-A 38-RS/WD	38		55	60	57	26.0	55	22	G 1 1/2" A	87.0

L<sub>1</sub> = approximate length with nut tightened

Please see "Engineering and technical data - Selecting the correct tube fitting" for more information on pressure.

# PIPE SCREW JOINTS

A MALE STUD FITTINGS



## A MALE STUD FITTING METRIC WD

Metric parallel.

Captive seal NBR (e.g. Perbunan),  
FKM (e.g. Viton) upon request.

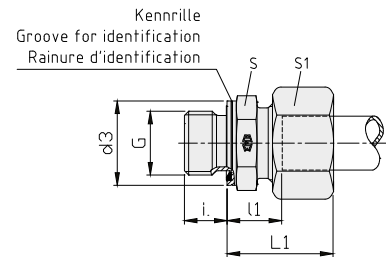

description	pipe OD	PN series	S	S <sub>1</sub>	L <sub>1</sub>	l <sub>1</sub>	d <sub>3</sub>	i	G	kg / 100 pcs
DS-A 6-ML/WD	6	L 500 (2200)	14	14	23	8.5	14	8	M 10 x 1	2.5
DS-A 8-ML/WD	8		17	17	25	10.0	17	12	M 12 x 1.5	4.0
DS-A 10-ML/WD	10		19	19	26	11.0	19	12	M 14 x 1.5	4.9
DS-A 12-ML/WD	12	L 400 (1700)	22	22	27	12.5	22	12	M 16 x 1.5	6.8
DS-A 12-L/M 18x1.5/WD	12		24	22	27	12.5	24	12	M 18 x 1.5	7.4
DS-A 12-L/M 22x1.5/WD	12		27	22	29	14.0	27	14	M 22 x 1.5	10.3
DS-A 15-ML/WD	15		24	27	29	13.5	24	12	M 18 x 1.5	9.5
DS-A 15-L/M 22x1.5/WD	15		27	27	30	15.0	27	14	M 22 x 1.5	12.0
DS-A 18-ML/WD	18	L 250 (1100)	27	32	31	14.5	27	14	M 22 x 1.5	13.7
DS-A 22-ML/WD	22		32	36	33	16.5	32	16	M 26 x 1.5	18.8
DS-A 28-ML/WD	28		41	41	34	17.5	40	18	M 33 x 2	25.8
DS-A 35-ML/WD	35		50	50	39	17.5	50	20	M 42 x 2	42.0
DS-A 42-ML/WD	42		55	60	42	19.0	55	22	M 48 x 2	57.5
DS-A 6-MS/WD	6	S 800 (3400)	17	17	28	13.0	17	12	M 12 x 1.5	4.7
DS-A 8-MS/WD	8		19	19	30	15.0	19	12	M 14 x 1.5	6.5
DS-A 10-MS/WD	10		22	22	31	15.0	22	12	M 16 x 1.5	8.6
DS-A 12-MS/WD	12	S 630 (2700)	24	24	33	17.0	24	12	M 18 x 1.5	10.9
DS-A 14-MS/WD	14		27	27	37	19.0	26	14	M 20 x 1.5	14.8
DS-A 16-MS/WD	16		27	30	37	18.5	27	14	M 22 x 1.5	16.6
DS-A 20-MS/WD	20	S 400 (1700)	32	36	42	20.5	32	16	M 27 x 2	25.3
DS-A 25-MS/WD	25		41	46	47	23.0	40	18	M 33 x 2	46.5
DS-A 30-MS/WD	30		50	50	50	23.5	50	20	M 42 x 2	64.4
DS-A 38-MS/WD	38		55	60	57	26.0	55	22	M 48 x 2	87.3

L<sub>1</sub> = approximate length with nut tightened

Please see "Engineering and technical data - Selecting the correct tube fitting" for more information on pressure.

# PIPE SCREW JOINTS

A MALE STUD FITTINGS



## A MALE STUD FITTING NPT

NPT (ANSI/ASME B1-20.1.1983).

Special dimensions.

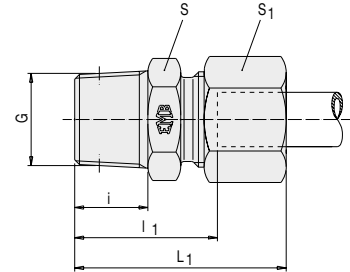

description	pipe OD	PN series	S	S <sub>1</sub>	L <sub>4</sub>	L <sub>4</sub>	i	G	kg / 100 pcs
A 4-LL/NPT	4	LL 100 (400)	11	10	28	18.0	10.0	1/8" NPT	1.5
A 6-LL/NPT	6		11	12	28	16.5	10.0	1/8" NPT	1.5
A 8-LL/NPT	8		12	14	30	18.5	10.0	1/8" NPT	2.0
DS-A 6-L / NPT	6	L 315 (1260)	12	14	32	18.0	10.0	1/8" NPT	2.6
DS-A 6-L 1/4" / NPT	6		17	14	38	23.0	15.1	1/4" NPT	3.8
DS-A 8-L / NPT	8		17	17	38	23.0	15.0	1/4" NPT	4.0
DS-A 10-L / NPT	10		17	19	39	24.0	15.0	1/4" NPT	4.8
DS-A 10-L 3/8" / NPT	10		19	19	40	25.0	15.2	3/8" NPT	6.0
DS-A 12-L / NPT	12		19	22	40	25.0	15.0	3/8" NPT	6.5
DS-A 12-L 1/4" / NPT	12		19	22	40	25.0	15.1	1/4" NPT	5.8
DS-A 12-L 1/2" / NPT	12		24	22	45	30.0	19.8	1/2" NPT	8.9
DS-A 15-L / NPT	15		24	27	46	31.0	20.0	1/2" NPT	11.0
DS-A 18-L / NPT	18		27	32	48	31.5	20.0	1/2" NPT	13.5
DS-A 22-L / NPT	22	L 160 (640)	32	36	50	33.5	20.0	3/4" NPT	19.0
DS-A 28-L / NPT	28		41	41	56	39.5	25.0	1" NPT	27.5
DS-A 35-L / NPT	35		46	50	62	40.0	25.6	1 1/4" NPT	40.5
DS-A 42-L / NPT	42		55	60	65	42.0	26.0	1 1/2" NPT	57.0
DS-A 6-S / NPT	6		17	17	43	26.0	15.0	1/4" NPT	5.0
DS-A 8-S / NPT	8	17	19	43	28.0	15.0	1/4" NPT	5.5	
DS-A 10-S / NPT	10	19	22	44	27.5	15.0	3/8" NPT	8.0	
DS-A 10-S 1/4" / NPT	10	19	22	44	27.5	15.1	1/4" NPT	7.6	
DS-A 12-S / NPT	12	S 630 (2520)	22	24	46	29.5	15.0	3/8" NPT	10.0
DS-A 12-S 1/4" / NPT	12		22	24	46	29.5	15.1	1/4" NPT	9.4
DS-A 12-S 1/2" / NPT	12		24	24	51	34.5	19.8	1/2" NPT	11.9
DS-A 14-S / NPT	14	24	27	54	36.0	20.0	1/2" NPT	15.5	
DS-A 16-S / NPT	16	27	30	54	35.5	20.0	1/2" NPT	16.0	
DS-A 20-S / NPT	20	32	36	59	37.5	20.0	3/4" NPT	25.0	
DS-A 25-S / NPT	25	41	46	69	45.0	25.0	1" NPT	47.5	
DS-A 30-S/NPT	30	46	50	73	46.0	25.6	1 1/4" NPT	62.0	
DS-A 38-S/NPT	38	55	60	80	49.0	26.0	1 1/2" NPT	89.0	

L<sub>4</sub> = approximate length with nut tightened

Please see "Engineering and technical data - Selecting the correct tube fitting" for more information on pressure.

# PIPE SCREW JOINTS

A MALE STUD FITTINGS

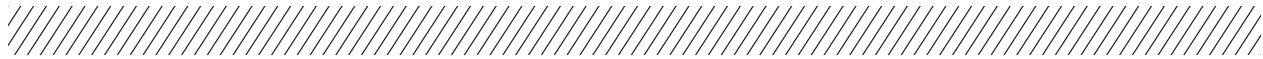

## AP MALE STUD FITTINGS BSP TAPER

BSP taper.

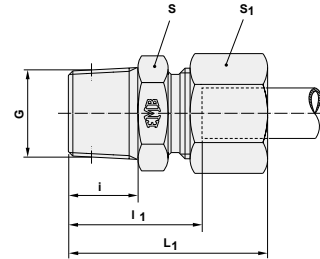

description	pipe OD	PN series	S	S <sub>1</sub>	L <sub>1</sub>	l <sub>1</sub>	i	G	kg / 100 pcs
DS-AP 6-L/R 1/8"	6	L 315 (1260)	12	14	30.0	15.0	8	R 1/8" K	2.2
DS-AP 8-L/R 1/4"	8		17	17	35.0	20.0	12	R 1/4" K	3.8
DS-AP 10-L/R 1/4"	10		17	19	37.0	22.0	12	R 1/4" K	4.3
DS-AP 12-L/R 3/8"	12		19	22	37.0	22.0	12	R 3/8" K	6.0
DS-AP 15-L/R 1/2"	15		24	27	40.0	25.0	14	R 1/2" K	10.3
DS-AP 18-L/R 1/2"	18		27	32	42.0	25.5	14	R 1/2" K	12.7
DS-AP 22-L/R 3/4"	22	L 160 (640)	32	36	46.0	29.5	16	R 3/4" K	18.5
DS-AP 28-L/R 1"	28		41	41	51.5	34.5	18	R 1" K	25.8
DS-AP 35-L/R 1 1/4"	35		50	50	56.0	34.5	20	R 1 1/4" K	41.5
DS-AP 42-L/R 1 1/2"	42		55	60	61.0	38.0	22	R 1 1/2" K	56.7

L<sub>1</sub> = approximate length with nut tightened

Please see "Engineering and technical data - Selecting the correct tube fitting" for more information on pressure.

# PIPE SCREW JOINTS

A MALE STUD FITTINGS



## A MALE STUD FITTING METRIC O-RING

Metric parallel (DIN ISO 6149-2 a. -3).

O-ring seal.

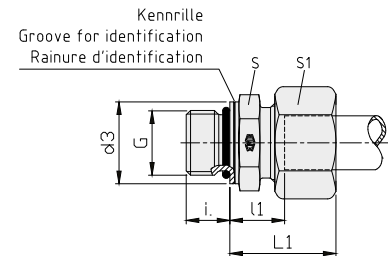

description	pipe OD	PN series	S	S <sub>1</sub>	L <sub>1</sub>	l <sub>1</sub>	d <sub>3</sub>	i	G	kg / 100 pcs	o-ring shore A-90
DS-A 6-ML/O	6	L 400 (1700)	14	14	24	9.5	14	9.5	M 10 x 1	2.4	8.1 x 1.6
DS-A 8-ML/O	8		17	17	24	10.0	17	11.0	M 12 x 1.5	3.8	9.3 x 2.2
DS-A 10-ML/O	10		19	19	25	11.0	19	11.0	M 14 x 1.5	5.1	11.3 x 2.2
DS-A 12-ML/O	12		22	22	27	12.5	22	11.5	M 16 x 1.5	6.8	13.3 x 2.2
DS-A 15-ML/O	15		24	27	28	13.5	24	14.0	M 18 x 1.5	9.5	15.3 x 2.2
DS-A 18-ML/O	18		27	32	30	14.5	27	15.0	M 22 x 1.5	14.0	19.3 x 2.2
DS-A 22-ML/O	22	L 250 (1100)	32	36	32	16.5	32	18.5	M 27 x 2	18.8	23.6 x 2.9
DS-A 28-ML/O	28		41	41	34	17.5	41	18.5	M 33 x 2	26.8	29.6 x 2.9
DS-A 35-ML/O	35		50	50	39	17.5	50	19.0	M 42 x 2	43.4	38.6 x 2.9
DS-A 6-MS/O	6	S 630 (2700)	17	17	27	13.0	17	11.0	M 12 x 1.5	4.8	9.3 x 2.2
DS-A 8-MS/O	8		19	19	29	15.0	19	11.0	M 14 x 1.5	6.4	11.3 x 2.2
DS-A 10-MS/O	10		22	22	31	15.0	22	12.5	M 16 x 1.5	8.6	13.3 x 2.2
DS-A 12-MS/O	12		24	24	33	17.0	24	14.0	M 18 x 1.5	10.9	15.3 x 2.2
DS-A 16-MS/O	16		27	30	36	18.5	27	15.0	M 22 x 1.5	16.6	19.3 x 2.2
DS-A 20-MS/O	20		32	36	42	20.5	32	18.5	M 27 x 2	26.2	23.6 x 2.9
DS-A 25-MS/O	25	S 400 (1700)	41	46	47	23.0	41	18.5	M 33 x 2	48.8	29.6 x 2.9
DS-A 30-MS/O	30		50	50	50	23.5	50	19.0	M 42 x 2	66.2	38.6 x 2.9

L<sub>1</sub> = approximate length with nut tightened

O-rings NBR (e.g. Perbunan), FKM (e.g. Viton) upon request

Please see "Engineering and technical data - Selecting the correct tube fitting" for more information on pressure.

# PIPE SCREW JOINTS

A MALE STUD FITTINGS



## A MALE STUD FITTING UNF/UN O-RING

UNF/UN (ISO 11926-2 and 3).

O-ring-seal.

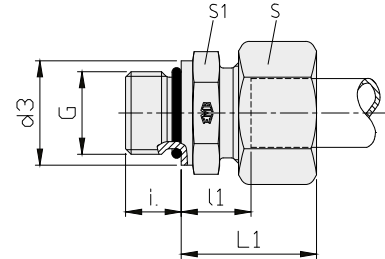

description	pipe OD	PN series	S	S <sub>1</sub>	L <sub>1</sub>	i <sub>1</sub>	d <sub>3</sub>	i	G	kg / 100 pcs	o-ring shore A-90	
DS-A 8-L/7/16"-20 UNF	8	L 400 (1700)	17	17	25	10.0	14	9.0	7/16-20 UNF-2A	3.6	8.92 x 1.83	
DS-A 10-L/7/16"-20 UNF	10		17	19	26	11.0	14	9.0	7/16-20 UNF-2A	4.2	8.92 x 1.83	
DS-A 12-L/9/16"-18 UNF	12		19	22	26	11.0	17	10.0	9/16-18 UNF-2A	5.6	12.00 x 2.00	
DS-A 12-L/3/4"-16 UNF	12		24	22	28	13.0	22	11.0	3/4-16 UNF-2A	7.6	16.36 x 2.21	
DS-A 12-L/7/8"-14 UNF	12		27	22	29	14.3	27	12.7	7/8-14 UNF-2A	10.1	19.18 x 2.46	
DS-A 15-L/3/4"-16 UNF	15		24	27	29	14.0	22	11.0	3/4-16 UNF-2A	9.7	16.36 x 2.21	
DS-A 15-L/7/8"-14 UNF	15		27	27	30	15.3	27	12.7	7/8-14 UNF-2A	12.0	19.18 x 2.46	
DS-A 18-L/3/4"-16 UNF	18		27	32	31	14.5	22	11.0	3/4-16 UNF-2A	13.1	16.36 x 2.21	
DS-A 18-L/7/8"-14 UNF	18		27	32	31	14.8	27	12.7	7/8-14 UNF-2A	13.7	19.18 x 2.46	
DS-A 22-L/7/8"-14 UNF	22		32	36	33	16.8	27	12.7	7/8-14 UNF-2A	18.0	19.18 x 2.46	
DS-A 22-L/1 1/16"-12 UN	22	L 250 (1100)	32	36	33	16.5	32	15.0	11/16-12 UN-2A	18.8	23.47 x 2.95	
DS-A 22-L 1 5/16"-12 UN	22		41	36	34	17.5	41	15.0	15/16-12 UN-2A	24.8	29.74 x 2.95	
DS-A 28-L/1 1/16"-12 UN	28		41	41	34	17.5	32	15.0	11/16-12 UN-2A	25.2	23.47 x 2.95	
DS-A 28-L/1 5/16"-12 UN	28		41	41	34	17.5	41	15.0	15/16-12 UN-2A	26.2	29.74 x 2.95	
DS-A 35-L/1 5/16"-12 UN	35		46	50	39	17.5	41	15.0	15/16-12 UN-2A	37.6	37.46 x 2.95	
DS-A 35-L/1 5/8"-12 UN	35		50	50	39	17.5	50	15.0	15/8-12 UN-2A	41.0	37.46 x 3	
DS-A 42-L/1 5/8"-12 UN	42		55	60	42	19.0	50	15.0	15/8-12 UN-2A	57.6	37.46 x 3	
DS-A 8-S/7/16"-20 UNF	8		S 630 (2700)	17	19	30	15.0	14	9.0	7/16-20 UNF-2A	5.4	8.92 x 1.83
DS-A 10-S/9/16"-18 UNF	10			19	22	31	14.5	17	10.0	9/16-18 UNF-2A	7.4	12.00 x 2.00
DS-A 12-S/9/16"-18 UNF	12			22	24	31	14.5	17	10.0	9/16-18 UNF-2A	8.6	12.00 x 2.00
DS-A 12-S 3/4"-16 UNF	12	24		24	34	17.5	22	11.0	3/4-16 UNF-2A	10.9	16.36 x 2.21	
DS-A 16-S/3/4"-16 UNF	16	24		30	34	15.5	22	11.0	3/4-16 UNF-2A	13.5	16.36 x 2.21	
DS-A 16-S/7/8"-14 UNF	16	27		30	37	18.8	27	12.7	7/8-14 UNF-2A	16.4	19.18 x 2.46	
DS-A 20-S 3/4"-16 UNF	20	32		36	42	20.5	22	11.0	3/4-16 UNF-2A	24.0	16.36 x 2.21	
DS-A 20-S/7/8"-14 UNF	20	32		36	42	20.8	27	12.7	7/8-14 UNF-2A	25.2	19.18 x 2.46	
DS-A 20-S/1 1/16"-12 UN	20	32		36	42	20.5	32	15.0	11/16-12 UN-2A	26.0	23.47 x 2.95	
DS-A 25-S/1 1/16"-12 UN	25	36		46	47	23.0	32	15.0	11/16-12 UN-2A	42.5	23.47 x 2.95	
DS-A 25-S/1 5/16"-12 UN	25	S 400 (1700)	41	46	47	23.0	41	15.0	15/16-12 UN-2A	47.7	29.74 x 2.95	
DS-A 30-S/1 5/16"-12 UN	30		46	50	50	23.5	41	15.0	15/16-12 UN-2A	56.3	29.74 x 2.95	
DS-A 30-S/1 5/8"-12 UN	30		50	50	50	23.5	50	15.0	15/8-12 UN-2A	63.4	37.46 x 3	
DS-A 38-S 1 5/8"-12 UN	38		55	60	57	26.0	50	15.0	15/8-12 UN-2A	89.4	37.46 x 3	

L<sub>1</sub> = approximate length with nut tightened

O-rings NBR (e.g. Perbunan). FKM (e.g. Viton) upon request

Please see "Engineering and technical data - Selecting the correct tube fitting" for more information on pressure.



# PIPE SCREW JOINTS

B MALE STUD ELBOWS



## B MALE STUD ELBOW BSP TAPER

BSP taper.

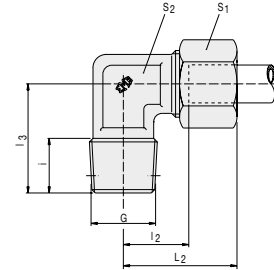

description	pipe OD	PN series	S <sub>1</sub>	S <sub>2</sub>	L <sub>2</sub>	l <sub>2</sub>	l <sub>3</sub>	i	G	kg / 100 pcs
B 4-RLL	4	LL 100 (400)	10	11	21	11.0	17	8	R 1/8" K	2.2
B 6-RLL	6		12	11	21	9.5	17	8	R 1/8" K	2.5
B 8-RLL	8		14	12	23	11.5	20	8	R 1/8" K	3.4
DS-B 6-RL	6	L 315 (1260)	14	12	27	12.0	20	8	R 1/8" K	4.0
DS-B 8-RL	8		17	14	29	14.0	26	12	R 1/4" K	6.6
DS-B 10-RL	10		19	17	30	15.0	27	12	R 1/4" K	8.3
DS-B 12-RL	12		22	19	32	17.0	28	12	R 3/8" K	11.8
DS-B 15-RL	15		27	19	36	21.0	34	14	R 1/2" K	13.0
DS-B 18-RL	18		32	24	40	23.5	36	14	R 1/2" K	16.6
DS-B 6-RS	6	S 630* (2520)	17	14	31	16.0	26	12	R 1/4" K	7.2
DS-B 8-RS	8		19	17	32	17.0	27	12	R 1/4" K	8.8
DS-B 10-RS	10		22	19	34	17.5	28	12	R 3/8" K	13.4
DS-B 12-RS	12		24	22	38	21.5	28	12	R 3/8" K	16.5
DS-B 14-RS	14		27	19	40	22.0	32	14	R 1/2" K	15.3
DS-B 16-RS	16		30	24	43	24.5	32	14	R 1/2" K	17.9

L<sub>2</sub> = approximate length with nut tightened

OD 4 to 12 mm manufactured from profile material

\* PN 630 applies only to taper port forms; PN 400 is applicable to parallel port forms

Please see "Engineering and technical data - Selecting the correct tube fitting" for more information on pressure.

# PIPE SCREW JOINTS

B MALE STUD ELBOWS



## B MALE STUD ELBOW METRIC TAPER

Metric taper.

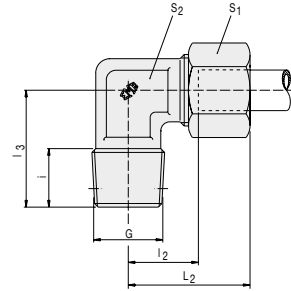

description	pipe OD	PN series	S <sub>1</sub>	S <sub>2</sub>	L <sub>2</sub>	l <sub>2</sub>	l <sub>3</sub>	i	G	kg / 100 pcs
B 4-MLL	4	LL 100 (400)	10	9	21	11.0	17	8	M 8x1 K	2.1
B 6-MLL	6		12	11	21	9.5	17	8	M 10x1 K	2.5
B 8-MLL	8		14	12	23	11.5	20	8	M 10x1 K	3.4
DS-B 6-ML	6	L 315 (1260)	14	12	27	12.0	20	8	M 10x1 K	4.0
DS-B 8-ML	8		17	14	29	14.0	26	12	M 12x1.5 K	6.6
DS-B 10-ML	10		19	17	30	15.0	27	12	M 14x1.5 K	8.3
DS-B 12-ML	12		22	19	32	17.0	28	12	M 16x1.5 K	11.8
DS-B 15-ML	15		27	19	36	21.0	32	12	M 18x1.5 K	12.0
DS-B 18-ML	18		32	24	40	23.5	36	14	M 22x1.5 K	19.1
DS-B 6-MS	6	S 630* (2520)	17	14	31	16.0	26	12	M 12x1.5 K	7.5
DS-B 8-MS	8		19	17	32	17.0	27	12	M 14x1.5 K	10.0
DS-B 10-MS	10		22	19	34	17.5	28	12	M 16x1.5 K	13.8
DS-B 12-MS	12		24	22	38	21.5	28	12	M 18x1.5 K	16.5
DS-B 14-MS	14		27	19	40	22.0	32	14	M 20x1.5 K	15.3
DS-B 16-MS	16		30	24	43	24.5	32	14	M 22x1.5 K	19.0

L<sub>2</sub> = approximate length with nut tightened

OD 4 to 12 mm manufactured from profile material

\* PN 630 applies only to taper port forms; PN 400 is applicable to parallel port forms

Please see "Engineering and technical data - Selecting the correct tube fitting" for more information on pressure.

# PIPE SCREW JOINTS

## B MALE STUD ELBOWS



### B MALE STUD ELBOW NPT

NPT (ANSI/ASME B1-20.1.1983).

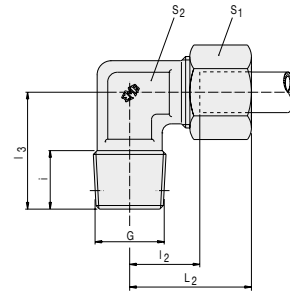

description	pipe OD	PN series	S <sub>1</sub>	S <sub>2</sub>	L <sub>2</sub>	l <sub>2</sub>	l <sub>3</sub>	i	G	kg / 100 pcs
B 4-LL/NPT	4	LL 100 (400)	10	11	21	11.0	17	10.0	1/8" NPT	2.1
B 6-LL/NPT	6		12	11	21	9.5	17	10.0	1/8" NPT	2.4
B 8-LL/NPT	8		14	12	23	11.5	20	10.0	1/8" NPT	3.3
DS-B 6-L/NPT	6	L 315 (1260)	14	12	27	12.0	20	10.0	1/8" NPT	4.0
DS-B 8-L/NPT	8		17	14	29	14.0	26	15.0	1/4" NPT	6.3
DS-B 10-L/NPT	10		19	17	30	15.0	27	15.0	1/4" NPT	8.2
DS-B 12-L/NPT	12		22	19	32	17.0	28	15.0	3/8" NPT	11.6
DS-B 15-L/NPT	15		27	19	36	21.0	34	20.0	1/2" NPT	14.0
DS-B 18-L/NPT	18		32	24	40	23.5	36	20.0	1/2" NPT	16.5
DS-B 22-L/NPT	22	L 160 (640)	36	27	44	27.5	42	20.0	3/4" NPT	23.5
DS-B 28-L/NPT	28		41	36	47	30.5	48	25.0	1" NPT	37.5
DS-B 35-L/NPT	35		50	41	56	34.5	54	25.5	1 1/4" NPT	57.5
DS-B 42-L/NPT	42		60	50	63	40.0	61	26.0	1 1/2" NPT	83.0
DS-B 6-S/NPT	6	S 630 (2520)	17	14	31	16.0	26	15.0	1/4" NPT	6.9
DS-B 8-S/NPT	8		19	17	32	17.0	27	15.0	1/4" NPT	8.5
DS-B 10-S/NPT	10		22	19	34	17.5	28	15.0	3/8" NPT	13.3
DS-B 12-S/NPT	12		24	22	38	21.5	28	15.0	3/8" NPT	16.8
DS-B 14-S/NPT	14		27	19	40	22.0	34	20.0	1/2" NPT	16.6
DS-B 16-S/NPT	16		30	24	43	24.5	36	20.0	1/2" NPT	18.6
DS-B 20-S/NPT	20	S 400 (1600)	36	27	48	26.5	42	20.0	3/4" NPT	30.0
DS-B 25-S/NPT	25		46	36	54	30.0	48	25.0	1" NPT	56.5
DS-B 30-S/NPT	30		50	41	62	35.5	54	25.5	1 1/4" NPT	82.0
DS-B 38-S/NPT	38		60	50	72	41.0	61	26.0	1 1/2" NPT	116.0

L<sub>2</sub> = approximate length with nut tightened

OD 4 to 12 mm manufactured from profile material

Please see "Engineering and technical data - Selecting the correct tube fitting" for more information on pressure.

# PIPE SCREW JOINTS

C MALE STUD BRANCH TEES



## C MALE STUD BRANCH TEE BSP TAPER

BSP taper.

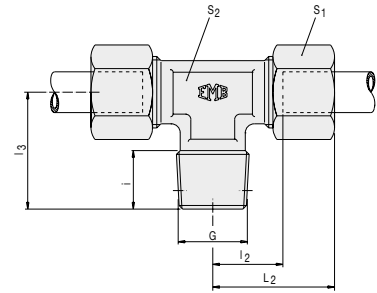

description	pipe OD	PN series	S <sub>1</sub>	S <sub>2</sub> *	L <sub>2</sub>	l <sub>2</sub>	l <sub>3</sub>	i	G	kg / 100 pcs
C 4-RLL	4	LL 100 (400)		10/9	21	11.0	17	8	R 1/8" K	2.9
C 6-RLL	6		12	11	21	9.5	17	8	R 1/8" K	3.4
C 8-RLL	8		14	12/14	23	11.5	20	8	R 1/8" K	4.7
DS-C 6-RL	6	L 315 (1260)	14	12/14	27	12.0	20	8	R 1/8" K	6.0
DS-C 8-RL	8		17	14	29	14.0	26	12	R 1/4" K	9.2
DS-C 10-RL	10		19	17	30	15.0	27	12	R 1/4" K	11.7
DS-C 12-RL	12		22	19	32	17.0	28	12	R 3/8" K	16.0
DS-C 15-RL	15		27	19	36	21.0	34	14	R 1/2" K	20.3
DS-C 18-RL	18		32	24	40	23.5	36	14	R 1/2" K	29.2
DS-C 6-RS	6	S 400 (1600)	17	14	31	16.0	26	12	R 1/4" K	10.9
DS-C 8-RS	8		19	17	32	17.0	27	12	R 1/4" K	14.0
DS-C 10-RS	10		22	19	34	17.5	28	12	R 3/8" K	19.0
DS-C 12-RS	12		24	22	38	21.5	28	12	R 3/8" K	24.5
DS-C 14-RS	14		27	19	40	22.0	32	14	R 1/2" K	24.4
DS-C 16-RS	16		30	24	43	24.5	32	14	R 1/2" K	28.4

L<sub>2</sub> = approximate length with nut tightened

OD 4 to 12 mm manufactured from profile material

Please see "Engineering and technical data - Selecting the correct tube fitting" for more information on pressure.

\* Depending on type of production, the wrench size may vary in some cases.

# PIPE SCREW JOINTS

C MALE STUD BRANCH TEES



## C MALE STUD BRANCH TEE METRIC TAPER

Metric taper.

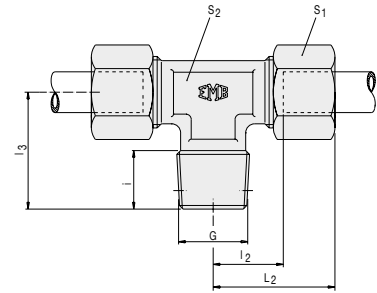

description	pipe OD	PN series	S <sub>1</sub>	S <sub>2</sub> *	L <sub>2</sub>	l <sub>2</sub>	l <sub>3</sub>	i	G	kg / 100 pcs
C 4-MLL	4	LL 100 (400)		10/9	21	11.0	17	8	M 8x1 K	2.8
C 6-MLL	6		12	11	21	9.5	17	8	M 10x1 K	3.4
C 8-MLL	8		14	12/14	23	11.5	20	8	M 10x1 K	4.7
DS-C 6-ML	6	L 315 (1260)	14	12/14	27	12.0	20	8	M 10x1 K	6.0
DS-C 8-ML	8		17	14	29	14.0	26	12	M 12x1.5 K	9.2
DS-C 10-ML	10		19	17	30	15.0	27	12	M 14x1.5 K	11.7
DS-C 12-ML	12		22	19	32	17.0	28	12	M 16x1.5 K	16.0
DS-C 15-ML	15		27	19	36	21.0	32	12	M 18x1.5 K	19.3
DS-C 18-ML	18		32	24	40	23.5	36	14	M 22x1.5 K	29.2
DS-C 6-MS	6	S 400 (1600)	17	14	31	16.0	26	12	M 12x1.5 K	10.9
DS-C 8-MS	8		19	17	32	17.0	27	12	M 14x1.5 K	14.0
DS-C 10-MS	10		22	19	34	17.5	28	12	M 16x1.5 K	19.0
DS-C 12-MS	12		24	22	38	21.5	28	12	M 18x1.5 K	24.5
DS-C 14-MS	14		27	19	40	22.0	32	14	M 20x1.5 K	24.4
DS-C 16-MS	16		30	24	43	24.5	32	14	M 22x1.5 K	28.4

L<sub>2</sub> = approximate length with nut tightened

OD 4 to 12 mm manufactured from profile material

Please see "Engineering and technical data - Selecting the correct tube fitting" for more information on pressure.

\* Depending on type of production, the wrench size may vary in some cases.

# PIPE SCREW JOINTS

C MALE STUD BRANCH TEES



## C MALE STUD BRANCH TEE NPT

NPT (ANSI/ASME B1-20.1.1983).

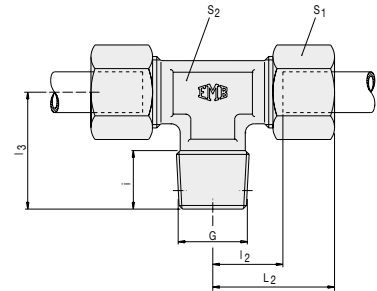

description	pipe OD	PN series	S <sub>1</sub>	S <sub>2</sub>	L <sub>2</sub>	l <sub>2</sub>	l <sub>3</sub>	i	G	kg / 100 pcs
C 4-LL/NPT	4	LL 100 (400)	10	11	21	11.0	17	10.0	1/8" NPT	2.2
C 6-LL/NPT	6		12	11	21	9.5	17	10.0	1/8" NPT	2.8
C 8-LL/NPT	8		14	12	23	11.5	20	10.0	1/8" NPT	3.7
DS-C 6-L/NPT	6	L 315 (1260)	14	12	27	12.0	20	10.0	1/8" NPT	4.5
DS-C 8-L/NPT	8		17	14	29	14.0	26	15.0	1/4" NPT	6.5
DS-C 10-L/NPT	10		19	17	30	15.0	27	15.0	1/4" NPT	8.5
DS-C 12-L/NPT	12		22	19	32	17.0	28	15.0	3/8" NPT	12.0
DS-C 15-L/NPT	15		27	19	36	21.0	34	20.0	1/2" NPT	21.0
DS-C 18-L/NPT	18		32	24	40	23.5	36	20.0	1/2" NPT	28.0
DS-C 22-L/NPT	22	L 160 (640)	36	27	44	27.5	42	20.0	3/4" NPT	38.0
DS-C 28-L/NPT	28		41	36	47	30.5	48	25.0	1" NPT	56.0
DS-C 35-L/NPT	35		50	41	56	34.5	54	25.5	1 1/4" NPT	91.0
DS-C 42-L/NPT	42		60	50	63	40.0	61	26.0	1 1/2" NPT	137.0
DS-C 6-S/NPT	6	S 630 (2520)	17	14	31	16.0	26	15.0	1/4" NPT	8.5
DS-C 8-S/NPT	8		19	17	32	17.0	27	15.0	1/4" NPT	10.5
DS-C 10-S/NPT	10		22	19	34	17.5	28	15.0	3/8" NPT	15.0
DS-C 12-S/NPT	12		24	22	38	21.5	28	15.0	3/8" NPT	18.0
DS-C 14-S/NPT	14		27	19	40	22.0	34	20.0	1/2" NPT	25.0
DS-C 16-S/NPT	16		30	24	43	24.5	36	20.0	1/2" NPT	34.5
DS-C 20-S/NPT	20	S 400 (1600)	36	27	48	26.5	42	20.0	3/4" NPT	49.5
DS-C 25-S/NPT	25		46	36	54	30.0	48	25.0	1" NPT	92.5
DS-C 30-S/NPT	30		50	41	62	35.5	54	25.5	1 1/4" NPT	128.0
DS-C 38-S/NPT	38		60	50	72	41.0	61	26.0	1 1/2" NPT	189.0

L<sub>2</sub> = approximate length with nut tightened

OD 4 to 12 mm manufactured from profile material

Please see "Engineering and technical data - Selecting the correct tube fitting" for more information on pressure.

# PIPE SCREW JOINTS

D MALE STUD RUN TEES



## D MALE STUD RUN TEE BSP TAPER

BSP taper.

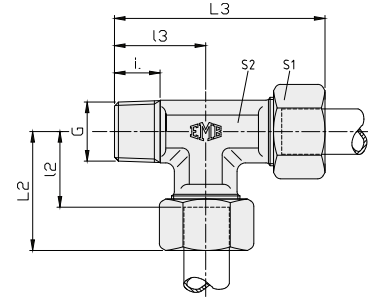

description	pipe OD	PN series	S <sub>1</sub>	S <sub>2</sub> *	L <sub>2</sub>	l <sub>2</sub>	L <sub>3</sub>	l <sub>3</sub>	i	G	kg / 100 pcs
D 4-RLL	4	LL 100 (400)	10	11	21	11.0	38	17	8	R 1/8" K	2.9
D 6-RLL	6		12	11	21	9.5	38	17	8	R 1/8" K	3.5
D 8-RLL	8		14	12	23	11.5	43	20	8	R 1/8" K	4.7
DS-D 6-RL	6	L 315 (1260)	14	12/14	27	12.0	47	20	8	R 1/8" K	6.0
DS-D 8-RL	8		17	14	29	14.0	55	26	12	R 1/4" K	9.1
DS-D 10-RL	10		19	17	30	15.0	57	27	12	R 1/4" K	11.4
DS-D 12-RL	12		22	19	32	17.0	60	28	12	R 3/8" K	16.2
DS-D 15-RL	15		27	19	36	21.0	70	34	14	R 1/2" K	20.0
DS-D 18-RL	18		32	24	40	23.5	76	36	14	R 1/2" K	26.7
DS-D 6-RS	6	S 400 (1600)	17	14	31	16.0	57	26	12	R 1/4" K	10.8
DS-D 8-RS	8		19	17	32	17.0	59	27	12	R 1/4" K	13.8
DS-D 10-RS	10		22	19	34	17.5	62	28	12	R 3/8" K	19.0
DS-D 12-RS	12		24	22	38	21.5	66	28	12	R 3/8" K	24.3
DS-D 14-RS	14		27	19	40	22.0	72	32	14	R 1/2" K	23.4
DS-D 16-RS	16		30	24	43	24.5	75	32	14	R 1/2" K	30.7

L<sub>2</sub>+L<sub>3</sub> = approximate length with nut tightened

OD 4 to 12 mm manufactured from profile material

Please see "Engineering and technical data - Selecting the correct tube fitting" for more information on pressure.

\* Depending on type of production, the wrench size may vary in some cases

# PIPE SCREW JOINTS

D MALE STUD RUN TEES



## D MALE STUD RUN TEE METRIC TAPER

Metric taper.

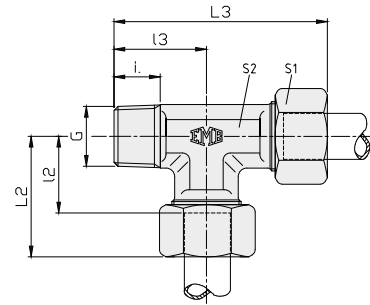

description	pipe OD	PN series	S <sub>1</sub>	S <sub>2</sub> *	L <sub>2</sub>	l <sub>2</sub>	L <sub>3</sub>	l <sub>3</sub>	i	G	kg / 100 pcs
D 4-MLL	4	LL 100 (400)	10	9	21	11.0	38	17	8	M 8x1 K	2.8
D 6-MLL	6		12	11	21	9.5	38	17	8	M 10x1 K	3.5
D 8-MLL	8		14	12	23	11.5	43	20	8	M 10x1 K	4.7
DS-D 6-ML	6	L 315 (1260)	14	12/14	27	12.0	47	20	8	M 10x1 K	6.0
DS-D 8-ML	8		17	14	29	14.0	55	26	12	M 12x1.5 K	9.1
DS-D 10-ML	10		19	17	30	15.0	57	27	12	M 14x1.5 K	11.4
DS-D 12-ML	12		22	19	32	17.0	60	28	12	M 16x1.5 K	16.2
DS-D 15-ML	15		27	19	36	21.0	68	32	12	M 18x1.5 K	18.6
DS-D 18-ML	18		32	24	40	23.5	76	36	14	M 22x1.5 K	26.6
DS-D 6-MS	6	S 400 (1600)	17	14	31	16.0	57	26	12	M 12x1.5 K	10.8
DS-D 8-MS	8		19	17	32	17.0	59	27	12	M 14x1.5 K	13.8
DS-D 10-MS	10		22	19	34	17.5	62	28	12	M 16x1.5 K	19.0
DS-D 12-MS	12		24	22	38	21.5	66	28	12	M 18x1.5 K	24.3
DS-D 14-MS	14		27	19	40	22.0	72	32	14	M 20x1.5 K	23.8
DS-D 16-MS	16		30	24	43	24.5	75	32	14	M 22x1.5 K	31.9

L<sub>2</sub>+L<sub>3</sub> = approximate length with nut tightened

OD 4 to 12 mm manufactured from profile material

Please see "Engineering and technical data - Selecting the correct tube fitting" for more information on pressure.

\* Depending on type of production, the wrench size may vary in some cases



# PIPE SCREW JOINTS

D MALE STUD RUN TEES



## D MALE STUD RUN TEE NPT

NPT (ANSI/ASME B1-20.1.1983).

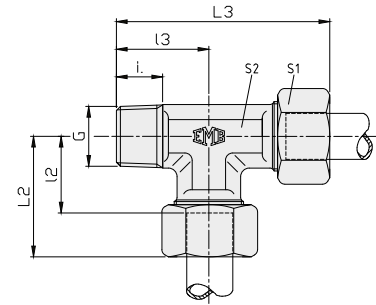

description	pipe OD	PN series	S <sub>1</sub>	S <sub>2</sub>	L <sub>2</sub>	l <sub>2</sub>	L <sub>3</sub>	l <sub>3</sub>	i	G	kg / 100 pcs
D 4-LL/NPT	4	LL 100 (400)	10	11	21	11.0	36	15	10.0	1/8" NPT	2.3
D 6-LL/NPT	6		12	9	21	9.5	36	15	10.0	1/8" NPT	2.9
D 8-LL/NPT	8		14	12	23	11.5	42	19	10.0	1/8" NPT	3.7
DS-D 6-L/NPT	6	L 315 (1260)	14	12	27	12.0	46	19	10.0	1/8" NPT	5.0
DS-D 8-L/NPT	8		17	14	29	14.0	52	23	15.0	1/4" NPT	6.5
DS-D 10-L/NPT	10		19	17	30	15.0	54	24	15.0	1/4" NPT	8.5
DS-D 12-L/NPT	12		22	19	32	17.0	57	25	15.0	3/8" NPT	12.5
DS-D 15-L/NPT	15		27	19	36	21.0	66	30	20.0	1/2" NPT	20.5
DS-D 18-L/NPT	18		32	24	40	23.5	73	33	20.0	1/2" NPT	26.5
DS-D 22-L/NPT	22	L 160 (640)	36	27	44	27.5	86	42	20.0	3/4" NPT	36.5
DS-D 28-L/NPT	28		41	36	47	30.5	95	48	25.0	1" NPT	56.0
DS-D 35-L/NPT	35		50	41	56	34.5	110	54	25.5	1 1/4" NPT	81.0
DS-D 42-L/NPT	42		60	50	63	40.0	124	61	26.0	1 1/2" NPT	115.0
DS-D 6-S/NPT	6	S 630 (2520)	17	14	31	16.0	54	23	15.0	1/4" NPT	9.0
DS-D 8-S/NPT	8		19	17	32	17.0	56	24	15.0	1/4" NPT	10.5
DS-D 10-S/NPT	10		22	19	34	17.5	59	25	15.0	3/8" NPT	15.6
DS-D 12-S/NPT	12		24	22	38	21.5	66	28	15.0	3/8" NPT	18.0
DS-D 14-S/NPT	14		27	19	40	22.0	70	30	20.0	1/2" NPT	24.5
DS-D 16-S/NPT	16		30	24	43	24.5	76	33	20.0	1/2" NPT	32.0
DS-D 20-S/NPT	20	S 400 (1600)	36	27	48	26.5	90	42	20.0	3/4" NPT	49.0
DS-D 25-S/NPT	25		46	36	54	30.0	102	48	25.0	1" NPT	82.2
DS-D 30-S/NPT	30		50	41	62	35.5	116	54	25.5	1 1/4" NPT	109.5
DS-D 38-S/NPT	38		60	50	72	41.0	133	61	26.0	1 1/2" NPT	155.0

L<sub>2</sub>+L<sub>3</sub> = approximate length with nut tightened

OD 4 to 12 mm manufactured from profile material

Please see "Engineering and technical data - Selecting the correct tube fitting" for more information on pressure.

# PIPE SCREW JOINTS

E STRAIGHT FITTINGS

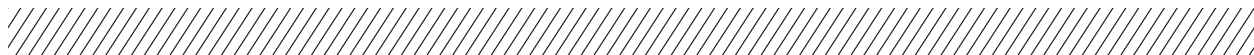

## E STRAIGHT FITTINGS

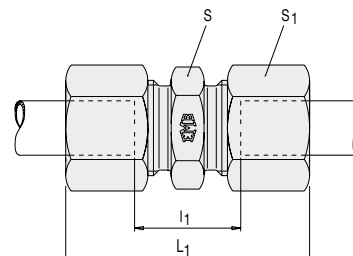

description	pipe OD	PN series	S	S <sub>1</sub>	L <sub>1</sub>	l <sub>1</sub>	kg / 100 pcs
E 4-LL	4		9	10	31	12	1.4
E 6-LL	6	LL 100 (400)	11	12	32	9	2.1
E 8-LL	8		12	14	35	12	2.6
DS-E 6-L	6		12	14	39	10	3.5
DS-E 8-L	8	L 500 (2200)	14	17	40	11	4.9
DS-E 10-L	10		17	19	42	13	6.9
DS-E 12-L	12		19	22	43	14	8.5
DS-E 15-L	15	400 (1700)	24	27	46	16	13.8
DS-E 18-L	18		27	32	48	16	19.5
DS-E 22-L	22		32	36	52	20	26.2
DS-E 28-L	28	250 (1100)	41	41	54	21	31.5
DS-E 35-L	35		46	50	63	20	49.4
DS-E 42-L	42		55	60	66	21	72.8
DS-E 6-S	6		14	17	45	16	5.9
DS-E 8-S	8	S 800 (3400)	17	19	47	18	7.8
DS-E 10-S	10		19	22	49	17	11.0
DS-E 12-S	12		22	24	51	19	13.6
DS-E 14-S	14	630 (2700)	24	27	57	22	18.2
DS-E 16-S	16		27	30	57	21	22.3
DS-E 20-S	20		32	36	66	23	34.7
DS-E 25-S	25	400 (1700)	41	46	74	26	66.9
DS-E 30-S	30		46	50	80	27	80.9
DS-E 38-S	38		55	60	90	29	119.4

L<sub>1</sub> = approximate length with nut tightened

Please see "Engineering and technical data - Selecting the correct tube fitting" for more information on pressure.

# PIPE SCREW JOINTS

ER STRAIGHT REDUCING FITTINGS



## ER STRAIGHT REDUCING FITTINGS

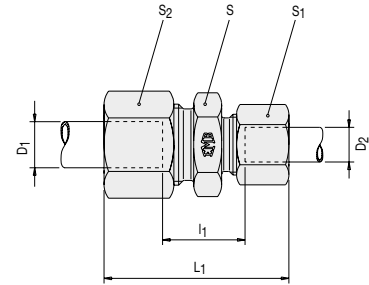

description	pipe OD <sub>1</sub>	Pipe OD <sub>2</sub>	PN series	S	S <sub>1</sub>	S <sub>2</sub>	L <sub>1</sub>	l <sub>1</sub>	kg / 100 pcs
ER 6/4-LL	6	4	LL 100 (400)	11	10	12	32	10.5	1.8
ER 8/4-LL	8	4		12	10	14	34	12.5	2.1
ER 8/6-LL	8	6		12	12	14	34	11.0	2.3
DS-ER 8/6-L	8	6	L 500 (2200)	14	14	17	40	11.0	4.3
DS-ER 10/6-L	10	6		17	14	19	41	12.0	5.2
DS-ER 10/8-L	10	8		17	17	19	41	12.0	5.7
DS-ER 12/6-L	12	6	L 400 (1700)	19	14	22	42	13.0	6.5
DS-ER 12/8-L	12	8		19	17	22	42	13.0	7.0
DS-ER 12/10-L	12	10		19	19	22	43	14.0	7.5
DS-ER 15/10-L	15	10		24	19	27	45	15.0	10.7
DS-ER 15/12-L	15	12		24	22	27	45	15.0	11.4
DS-ER 18/10-L	18	10		27	19	32	46	15.5	14.3
DS-ER 18/12-L	18	12		27	22	32	46	15.5	15.0
DS-ER 18/15-L	18	15		27	27	32	48	16.5	17.2
DS-ER 22/12-L	22	12		32	22	36	48	17.5	19.3
DS-ER 22/15-L	22	15		32	27	36	50	18.5	21.8
DS-ER 22/18-L	22	18	L 250 (1100)	32	32	36	50	18.0	23.8
DS-ER 28/18-L	28	18		41	32	41	52	19.0	30.6
DS-ER 28/22-L	28	22		41	36	41	54	21.0	32.6
DS-ER 35/22-L	35	22		46	36	50	59	21.0	44.3
DS-ER 35/28-L	35	28	46	41	50	59	21.0	46.1	
DS-ER 8/6-S	8	6	S 800 (3400)	17	17	19	47	18.0	7.4
DS-ER 10/6-S	10	6		19	17	22	48	17.5	9.1
DS-ER 10/8-S	10	8		19	19	22	48	17.5	9.5
DS-ER 12/6-S	12	6	S 630 (2700)	22	17	24	50	19.5	11.1
DS-ER 12/8-S	12	8		22	19	24	50	19.5	11.5
DS-ER 12/10-S	12	10		22	22	24	51	19.0	12.7
DS-ER 14/10-S	14	10		24	22	27	54	20.5	15.6
DS-ER 14/12-S	14	12		24	24	27	54	20.5	16.2
DS-ER 16/12-S	16	12		27	24	30	54	20.0	18.8
DS-ER 16/14-S	16	14		27	27	30	57	21.5	21.2
DS-ER 20/10-S	20	10	S 400 (1700)	32	22	36	60	22.0	27.1
DS-ER 20/12-S	20	12		32	24	36	60	22.0	27.7
DS-ER 20/16-S	20	16		32	30	36	63	23.0	31.3
DS-ER 25/16-S	25	16		41	30	46	68	25.5	51.2
DS-ER 25/20-S	25	20		41	36	46	71	25.5	56.4
DS-ER 30/20-S	30	20		46	36	50	74	26.0	65.1
DS-ER 30/25-S	30	25		46	46	50	77	26.5	77.8
DS-ER 38/30-S	38	30		55	50	60	87	29.5	110.3

L<sub>1</sub> = approximate length with nut tightened

Please see "Engineering and technical data - Selecting the correct tube fitting" for more information on pressure.

# PIPE SCREW JOINTS

F EQUAL ELBOWS



## F EQUAL ELBOWS

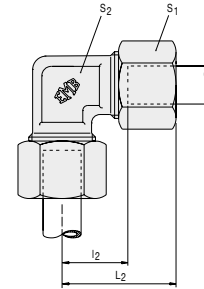

description	pipe OD	PN series	S <sub>1</sub>	S <sub>2</sub> *	L <sub>2</sub>	l <sub>2</sub>	kg / 100 pcs
F 4-LL	4		10	9	21	11.0	2.5
F 6-LL	6	LL 100 (400)	12	11	21	9.5	2.8
F 8-LL	8		14	12	23	11.5	3.8
DS-F 6-L	6		14	12	27	12.0	4.9
DS-F 8-L	8	L 500 (2200)	17	14	29	14.0	7.6
DS-F 10 L	10		19	14/ 17	30	15.0	9.6
DS-F 12-L	12		22	17	32	17.0	13.5
DS-F 15-L	15	L 400 (1700)	27	19	36	21.0	15.8
DS-F 18-L	18		32	24	40	23.5	23.9
DS-F 22-L	22		36	27	44	27.5	31.7
DS-F 28-L	28	L 250 (1100)	41	36	47	30.5	42.0
DS-F 35-L	35		50	41	56	34.5	75.9
DS-F 42-L	42		60	50	63	40.0	107.8
DS-F 6-S	6		17	14	31	16.0	8.5
DS-F 8-S	8	S 800 (3400)	19	14/ 17	32	17.0	11.7
DS-F 10-S	10		22	17	34	17.5	16.1
DS-F 12-S	12		24	22	38	21.5	20.5
DS-F 14-S	14	S 630 (2700)	27	19	40	22.0	20.7
DS-F 16-S	16		30	24	43	24.5	25.0
DS-F 20-S	20		36	27	48	26.5	40.7
DS-F 25-S	25	S 400 (1700)	46	36	54	30.0	77.6
DS-F 30-S	30		50	41	62	35.5	97.4
DS-F 38-S	38		60	50	72	41.0	131.8

L<sub>2</sub> = approximate length with nut tightened

OD 4 to 12 mm manufactured from profile material

Please see "Engineering and technical data - Selecting the correct tube fitting" for more information on pressure.

\* Depending on type of production, the wrench size may vary in some cases

# PIPE SCREW JOINTS

G EQUAL TEES



## G EQUAL TEES

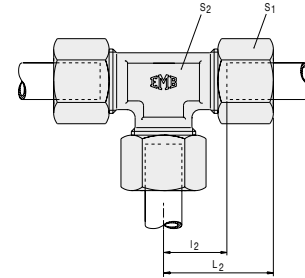

description	pipe OD	PN series	S <sub>1</sub>	S <sub>2</sub> *	L <sub>2</sub>	l <sub>2</sub>	kg / 100 pcs
G 4-LL	4	LL 100 (400)	10	9	21	11.0	2.9
G 6-LL	6		12	12	21	9.5	3.8
G 8-LL	8		14	12/14	23	11.5	5.1
DS-G 6-L	6	L 500 (2200)	14	12	27	12.0	7.1
DS-G 8-L	8		17	14	29	14.0	10.1
DS-G 10-L	10		19	17	30	15.0	13.0
DS-G 12-L	12		22	19	32	17.0	17.7
DS-G 15-L	15	L 400 (1700)	27	19	36	21.0	23.2
DS-G 18-L	18		32	24	40	23.5	35.4
DS-G 22-L	22	L 250 (1100)	36	27	44	27.5	44.3
DS-G 28-L	28		41	36	47	30.5	61.1
DS-G 35-L	35		50	41	56	34.5	90.1
DS-G 42-L	42		60	50	63	40.0	136.8
DS-G 6-S	6	S 800 (3400)	17	14	31	16.0	12.0
DS-G 8-S	8		19	17	32	17.0	15.7
DS-G 10-S	10		22	19	34	17.5	21.2
DS-G 12-S	12	S 630 (2700)	24	22/17	38	21.5	28.5
DS-G 14-S	14		27	19	40	22.0	28.5
DS-G 16-S	16	S 400 (1700)	30	24	43	24.5	35.9
DS-G 20-S	20		36	27	48	26.5	55.8
DS-G 25-S	25		46	36	54	30.0	106.7
DS-G 30-S	30		50	41	62	35.5	134.9
DS-G 38-S	38		60	50	72	41.0	202.2

L<sub>2</sub> = approximate length with nut tightened

OD 4 to 12 mm manufactured from profile material

Please see "Engineering and technical data - Selecting the correct tube fitting" for more information on pressure.

\* Depending on type of production, the wrench size may vary in some cases

# PIPE SCREW JOINTS

GR TEE REDUCERS



## GR TEE REDUCERS

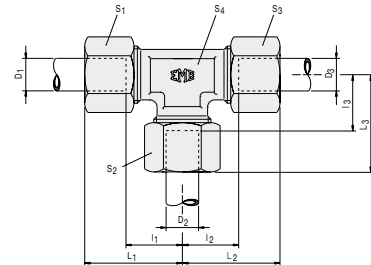

description	pipe OD <sub>1</sub>	Pipe OD <sub>2</sub>	Pipe OD <sub>3</sub>	PN series	S <sub>1</sub>	S <sub>2</sub>	S <sub>3</sub>	S <sub>4</sub>	L <sub>1</sub>	L <sub>2</sub>	L <sub>3</sub>	I <sub>1</sub>	I <sub>2</sub>	I <sub>3</sub>	kg / 100 pcs
GR 4/8/4-LL	4	8	4	LL 100 (400)	10	14	10	12	23	23	23	13.0	13.0	11.5	4.3
GR 6/4/6-LL	6	4	6		12	10	12	11	21	21	21	9.5	9.5	11.0	3.5
DS-GR 6/8/6-L	6	8	6		14	17	14	14	29	29	29	14.0	14.0	14.0	9.2
DS-GR 8/6/8-L	8	6	8		17	14	17	14	29	29	29	14.0	14.0	14.0	9.5
DS-GR 6/10/6-L	6	10	6	L 500 (2200)	14	19	14	14	30	30	30	15.0	15.0	15.0	11.4
DS-GR 8/10/8-L	8	10	8		17	19	17	14	30	30	30	15.0	15.0	15.0	12.2
DS-GR 10/6/10-L	10	6	10		19	14	19	14	30	30	30	15.0	15.0	15.0	12.1
DS-GR 10/8/10-L	10	8	10		19	17	19	14	30	30	30	15.0	15.0	15.0	12.2
DS-GR 10/10/6-L	10	10	6		19	19	14	14	30	30	30	15.0	15.0	15.0	12.1
DS-GR 8/12/8-L	8	12	8		17	22	17	17	32	32	32	17.0	17.0	17.0	16.0
DS-GR 12/6/12-L	12	6	12		22	14	22	17	32	32	32	17.0	17.0	17.0	15.9
DS-GR 12/8/8-L	12	8	8		22	17	17	17	32	32	32	17.0	17.0	17.0	16.0
DS-GR 12/8/12-L	12	8	12		22	17	22	17	32	32	32	17.0	17.0	17.0	16.4
DS-GR 12/10/10-L	12	10	10		22	19	19	17	32	32	32	17.0	17.0	17.0	16.2
DS-GR 12/10/12-L	12	10	12		22	19	22	17	32	32	32	17.0	17.0	17.0	16.7
DS-GR 12/12/10-L	12	12	10		22	22	19	17	32	32	32	17.0	17.0	17.0	16.7
DS-GR 10/15/10-L	10	15	10		19	27	19	19	36	36	36	21.0	21.0	21.0	18.8
DS-GR 12/15/12-L	12	15	12		22	27	22	19	36	36	36	21.0	21.0	21.0	19.2
DS-GR 15/6/15-L	15	6	15	L 400 (1700)	27	14	27	19	36	36	36	21.0	21.0	21.0	19.4
DS-GR 15/10/15-L	15	10	15		27	19	27	19	36	36	36	21.0	21.0	21.0	20.7
DS-GR 15/12/12-L	15	12	12		27	22	22	19	36	36	36	21.0	21.0	21.0	18.8
DS-GR 15/12/15-L	15	12	15		27	22	27	19	36	36	36	21.0	21.0	21.0	21.1
DS-GR 15/15/12-L	15	15	12		27	27	22	19	36	36	36	21.0	21.0	21.0	20.8
DS-GR 12/18/12-L	12	18	12		22	32	22	24	39	39	40	24.0	24.0	23.5	26.3
DS-GR 18/10/10-L	18	10	10		32	19	19	24	40	39	39	23.5	24.0	24.0	25.9
DS-GR 18/10/18-L	18	10	18		32	19	32	24	40	40	39	23.5	23.5	24.0	29.7
DS-GR 18/12/18-L	18	12	18		32	22	32	24	40	40	39	23.5	23.5	24.0	29.7
DS-GR 18/15/18-L	18	15	18		32	27	32	24	40	40	39	23.5	23.5	24.0	31.6
DS-GR 18/18/10-L	18	18	10		32	32	19	24	40	39	40	23.5	24.0	23.5	29.6
DS-GR 22/10/22-L	22	10	22		36	19	36	27	44	44	43	27.5	27.5	28.0	39.1
DS-GR 22/12/22-L	22	12	22		36	22	36	27	44	44	43	27.5	27.5	28.0	39.7
DS-GR 22/15/15-L	22	15	15		36	27	27	27	44	43	43	27.5	28.0	28.0	37.7
DS-GR 22/15/22-L	22	15	22		36	27	36	27	44	44	43	27.5	27.5	28.0	41.0
DS-GR 22/18/18-L	22	18	18	L 250 (1100)	36	32	32	27	44	44	44	27.5	27.5	27.5	42.2
DS-GR 22/18/22-L	22	18	22		36	32	36	27	44	44	44	27.5	27.5	27.5	43.5
DS-GR 22/22/18-L	22	22	18		36	36	32	27	44	44	44	27.5	27.5	27.5	43.1
DS-GR 28/10/28-L	28	10	28		41	19	41	36	47	47	46	30.5	30.5	31.0	55.7
DS-GR 28/12/28-L	28	12	28		41	22	41	36	47	47	46	30.5	30.5	31.0	56.3
DS-GR 28/15/28-L	28	15	28		41	27	41	36	47	47	46	30.5	30.5	31.0	59.7

# PIPE SCREW JOINTS

GR TEE REDUCERS (CONTINUED)



description	pipe OD <sub>1</sub>	pipe OD <sub>2</sub>	pipe OD <sub>3</sub>	PN series	S <sub>1</sub>	S <sub>2</sub>	S <sub>3</sub>	S <sub>4</sub>	L <sub>1</sub>	L <sub>2</sub>	L <sub>3</sub>	l <sub>1</sub>	l <sub>2</sub>	l <sub>3</sub>	kg / 100 pcs
DS-GR 28/18/28-L	28	18	28	L 250 (1100)	41	32	41	36	47	47	47	30.5	30.5	30.5	59.7
DS-GR 28/22/22-L	28	22	22		41	36	36	36	47	47	47	30.5	30.5	30.5	60.2
DS-GR 28/22/28-L	28	22	28		41	36	41	36	47	47	47	30.5	30.5	30.5	60.3
DS-GR 10/6/10-S	10	6	10	S 800 (3400)	22	17	22	17	34	34	33	17.5	17.5	18.0	19.9
DS-GR 12/8/8-S	12	8	8		24	19	19	17	38	37	37	21.5	22.0	22.0	25.1
DS-GR 12/8/12-S	12	8	12		24	19	24	17	38	38	37	21.5	21.5	22.0	26.6
DS-GR 12/10/12-S	12	10	12		24	22	24	17	38	38	38	21.5	21.5	21.5	27.5
DS-GR 12/16/12-S	12	16	12		24	30	24	24	42	42	43	25.5	25.5	24.5	32.9
DS-GR 16/6/16-S	16	6	16		30	17	30	24	43	43	41	24.5	24.5	26.0	33.3
DS-GR 16/8/16-S	16	8	16		30	19	30	24	43	43	41	24.5	24.5	26.0	33.2
DS-GR 16/10/16-S	16	10	16		30	22	30	24	43	43	42	24.5	24.5	25.5	34.8
DS-GR 16/12/16-S	16	12	16		30	24	30	24	43	43	42	24.5	24.5	25.5	35.6
DS-GR 16/20/16-S	16	20	16		S 400 (1700)	30	36	30	27	47	47	48	28.5	28.5	26.5
DS-GR 20/10/20-S	20	10	20	36		22	36	27	48	48	46	26.5	26.5	29.5	51.7
DS-GR 20/12/20-S	20	12	20	36		24	36	27	48	48	46	26.5	26.5	29.5	52.4
DS-GR 20/16/20-S	20	16	20	36		30	36	27	48	48	47	26.5	26.5	28.5	54.2
DS-GR 20/25/20-S	20	25	20	36		46	36	36	53	53	54	31.5	31.5	30.0	89.1
DS-GR 25/16/25-S	25	16	25	46		30	46	36	54	54	52	30.0	30.0	33.5	96.6
DS-GR 25/20/25-S	25	20	25	46		36	46	36	54	54	53	30.0	30.0	31.5	99.8
DS-GR 25/30/25-S	25	30	25	46		50	46	41	61	61	62	37.0	37.0	35.5	139.4

$L_1+L_2+L_3$  = approximate length with nut tightened

Please see "Engineering and technical data - Selecting the correct tube fitting" for more information on pressure.

# PIPE SCREW JOINTS

H EQUAL CROSSES



## H EQUAL CROSSES

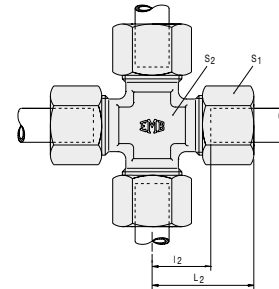

description	pipe OD	PN series	S <sub>1</sub>	S <sub>2</sub>	L <sub>2</sub>	l <sub>2</sub>	kg / 100 pcs
DS-H 6-L	6	L 500 (2200)	14	12	27	12.0	7.7
DS-H 8-L	8		17	12	29	14.0	10.9
DS-H 10-L	10		19	14	30	15.0	15.5
DS-H 12-L	12	L 400 (1700)	22	17	32	17.0	19.2
DS-H 15-L	15		27	19	36	21.0	31.1
DS-H 18-L	18		32	24	40	23.5	48.3
DS-H 22-L	22	L 250 (1100)	36	27	44	27.5	72.4
DS-H 28-L	28		41	36	47	30.5	101.2
DS-H 35-L	35		50	41	56	34.5	122.8
DS-H 42-L	42	S 800 (3400)	60	50	63	40.0	175.6
DS-H 6-S	6		17	12	31	16.0	12.3
DS-H 8-S	8		19	14	32	17.0	14.8
DS-H 10-S	10	S 630 (2700)	22	17	34	17.5	23.0
DS-H 12-S	12		24	17	38	21.5	28.2
DS-H 14-S	14		27	19	40	22.0	35.4
DS-H 16-S	16	S 400 (1700)	30	24	43	24.5	45.1
DS-H 20-S	20		36	27	48	26.5	70.4
DS-H 25-S	25		46	36	54	30.0	125.7
DS-H 30-S	30	S 400 (1700)	50	41	62	35.5	150.3
DS-H 38-S	38		60	50	72	41.0	205.1

*L<sub>2</sub>* = approximate length with nut tightened

Please see "Engineering and technical data - Selecting the correct tube fitting" for more information on pressure.



# PIPE SCREW JOINTS

K STRAIGHT BULKHEAD FITTINGS



## K STRAIGHT BULKHEAD FITTING

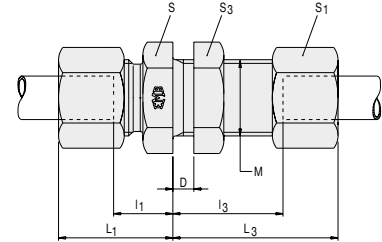

description	pipe OD	PN series	S	S <sub>1</sub>	S <sub>3</sub>	L <sub>1</sub>	l <sub>1</sub>	Dmax	L <sub>3</sub>	l <sub>3</sub>	M	kg / 100 pcs
DS-K 6-L	6	L 500 (2200)	17	14	17	22	7.0	16	42	27.0	M 12x1.5	6.7
DS-K 8-L	8		19	17	19	23	8.0	16	42	27.0	M 14x1.5	8.4
DS-K 10-L	10		22	19	22	25	10.0	16	43	28.0	M 16x1.5	11.0
DS-K 12-L	12	L 400 (1700)	24	22	24	25	10.0	16	44	29.0	M 18x1.5	13.3
DS-K 15-L	15		27	27	30	27	12.0	16	46	31.0	M 22x1.5	22.8
DS-K 18-L	18		32	32	36	30	13.5	16	49	32.5	M 26x1.5	33.2
DS-K 22-L	22	L 250 (1100)	36	36	41	33	16.5	16	51	34.5	M 30x2	41.5
DS-K 28-L	28		41	41	46	35	18.5	16	52	35.5	M 36x2	52.5
DS-K 35-L	35		50	50	55	40	18.5	16	58	36.5	M 45x2	80.0
DS-K 42-L	42	S 800 (3400)	60	60	65	42	19.0	16	59	36.0	M 52x2	119.3
DS-K 6-S	6		19	17	19	27	12.0	16	44	29.0	M 14x1.5	9.6
DS-K 8-S	8		22	19	22	28	13.0	16	44	29.0	M 16x1.5	12.4
DS-K 10-S	10	S 630 (2700)	24	22	24	31	14.5	16	46	29.5	M 18x1.5	18.1
DS-K 12-S	12		27	24	27	31	14.5	16	47	30.5	M 20x1.5	21.0
DS-K 14-S	14		30	27	30	35	17.0	16	50	32.0	M 22x1.5	29.0
DS-K 16-S	16	S 400 (1700)	32	30	32	35	16.5	16	50	31.5	M 24x1.5	31.0
DS-K 20-S	20		41	36	41	39	17.5	16	55	33.5	M 30x2	54.5
DS-K 25-S	25		46	46	46	44	20.0	16	59	35.0	M 36x2	89.0
DS-K 30-S	30	S 400 (1700)	50	50	50	48	21.5	16	64	37.5	M 42x2	107.7
DS-K 38-S	38		65	60	65	53	22.0	16	68	37.0	M 52x2	173.0

$L_1+L_3$  = approximate length with nut tightened

Please see "Engineering and technical data - Selecting the correct tube fitting" for more information on pressure.

# PIPE SCREW JOINTS

L BULKHEAD ELBOW FITTINGS



## L BULKHEAD ELBOW FITTING

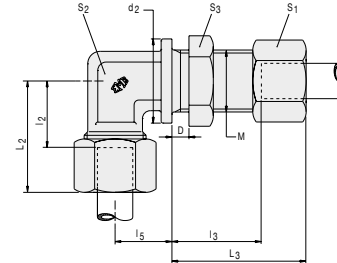

description	pipe OD	PN series	S <sub>1</sub>	S <sub>2</sub>	S <sub>3</sub>	L <sub>2</sub>	l <sub>2</sub>	l <sub>5</sub>	Dmax	L <sub>3</sub>	l <sub>3</sub>	d <sub>2</sub>	M	kg / 100 pcs
DS-L 6-L	6	L 500 (2200)	14	12	17	27	12.0	14	16	42	27.0	17	M 12x1.5	7.5
DS-L 8-L	8		17	12	19	29	14.0	17	16	42	27.0	19	M 14x1.5	9.9
DS-L 10-L	10		19	14	22	30	15.0	18	16	43	28.0	22	M 16x1.5	12.0
DS-L 12-L	12	L 400 (1700)	22	17	24	32	17.0	20	16	44	29.0	24	M 18x1.5	15.0
DS-L 15-L	15		27	19	30	36	21.0	23	16	46	31.0	27	M 22x1.5	25.0
DS-L 18-L	18		32	24	36	40	23.5	24	16	49	32.5	32	M 26x1.5	35.5
DS-L 22-L	22	L 250 (1100)	36	27	41	44	27.5	30	16	51	34.5	36	M 30x2	46.5
DS-L 28-L	28		41	36	46	47	30.5	34	16	52	35.5	42	M 36x2	64.0
DS-L 35-L	35		50	41	55	56	34.5	39	16	58	36.5	50	M 45x2	99.4
DS-L 42-L	42	S 800 (3400)	60	50	65	63	40.0	43	16	59	36.0	60	M 52x2	149.0
DS-L 6-S	6		17	12	19	31	16.0	17	16	44	29.0	19	M 14x1.5	10.5
DS-L 8-S	8		19	14	22	32	17.0	18	16	44	29.0	22	M 16x1.5	14.0
DS-L 10-S	10	S 630 (2700)	22	17	24	34	17.5	20	16	46	29.5	24	M 18x1.5	19.0
DS-L 12-S	12		24	17	27	38	21.5	21	16	47	30.5	27	M 20x1.5	22.5
DS-L 14-S	14		27	19	30	40	22.0	23	16	50	32.0	27	M 22x1.5	30.0
DS-L 16-S	16	S 400 (1700)	30	24	32	43	24.5	24	16	50	31.5	30	M 24x1.5	36.5
DS-L 20-S	20		36	27	41	48	26.5	30	16	55	33.5	36	M 30x2	58.0
DS-L 25-S	25		46	36	46	54	30.0	34	16	59	35.0	42	M 36x2	100.0
DS-L 30-S	30	S 400 (1700)	50	41	50	62	35.5	39	16	64	37.5	50	M 42x2	130.0
DS-L 38-S	38		60	50	65	72	41.0	43	16	68	37.0	60	M 52x2	197.0

$L_2+L_3$  = approximate length with nut tightened

Please see "Engineering and technical data - Selecting the correct tube fitting" for more information on pressure.

# PIPE SCREW JOINTS

N WELDING BULKHEAD FITTINGS



## N WELDING BULKHEAD FITTING

Socket material: steel, fusion weldable.

Socket surface: bright, oiled.

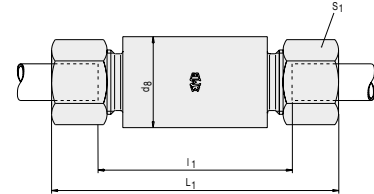

description	pipe OD	PN series	S <sub>1</sub>	L <sub>1</sub>	l <sub>1</sub>	d <sub>8</sub>	kg / 100 pcs
DS-N 6-L	6	L 500 (2200)	14	85	56	18	13.1
DS-N 8-L	8		17	85	56	20	16.2
DS-N 10-L	10		19	87	58	22	19.5
DS-N 12-L	12	L 400 (1700)	22	87	58	25	24.1
DS-N 15-L	15		27	100	70	28	35.3
DS-N 18-L	18		32	101	69	32	46.9
DS-N 22-L	22	L 250 (1100)	36	105	73	36	58.2
DS-N 28-L	28		41	106	73	40	66.0
DS-N 35-L	35		50	114	71	50	102.9
DS-N 42-L	42	S 800 (3400)	60	115	70	60	148.8
DS-N 6-S	6		17	89	60	20	16.9
DS-N 8-S	8		19	89	60	22	20.4
DS-N 10-S	10	S 630 (2700)	22	91	59	25	27.0
DS-N 12-S	12		24	91	59	28	33.1
DS-N 14-S	14		27	107	72	30	44.7
DS-N 16-S	16	S 400 (1700)	30	107	71	35	57.8
DS-N 20-S	20		36	114	71	38	73.2
DS-N 25-S	25		46	120	72	45	114.6
DS-N 30-S	30	S 400 (1700)	50	126	73	50	134.4
DS-N 38-S	38		60	133	72	60	191.3

L<sub>1</sub> = approximate length with nut tightened

Please see "Engineering and technical data - Selecting the correct tube fitting" for more information on pressure.

# PIPE SCREW JOINTS

V WELDING BOSSES



## V WELDING BOSSES

Socket material: steel, fusion weldable.

Socket surface: bright, oiled.

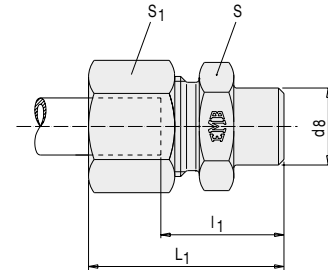

description	pipe OD	PN series	S	S <sub>1</sub>	L <sub>1</sub>	l <sub>1</sub>	d <sub>8</sub>	kg / 100 pcs
DS-V 6-L	6	L 500 (2200)	12	14	29	14.0	10	2.5
DS-V 8-L	8		14	17	31	16.0	12	3.6
DS-V 10-L	10		17	19	33	18.0	14	4.7
DS-V 12-L	12	L 400 (1700)	19	22	33	18.0	16	6.3
DS-V 15-L	15		22	27	37	22.0	19	8.4
DS-V 18-L	18		27	32	40	23.5	22	13.9
DS-V 22-L	22	L 250 (1100)	32	36	45	28.5	27	18.1
DS-V 28-L	28		41	41	47	30.5	32	30.2
DS-V 35-L	35		46	50	54	32.5	40	37.7
DS-V 42-L	42	S 800 (3400)	55	60	58	35.0	46	64.1
DS-V 6-S	6		14	17	34	19.0	11	3.2
DS-V 8-S	8		17	19	36	21.0	13	4.9
DS-V 10-S	10	S 630 (2700)	19	22	39	22.5	15	7.2
DS-V 12-S	12		22	24	41	24.5	17	8.3
DS-V 14-S	14		24	27	45	27.0	19	10.8
DS-V 16-S	16	S 400 (1700)	27	30	45	26.5	21	14.4
DS-V 20-S	20		32	36	51	29.5	26	21.8
DS-V 25-S	25		41	46	56	32.0	31	37.7
DS-V 30-S	30	S 400 (1700)	46	50	62	35.5	36	44.9
DS-V 38-S	38		55	60	69	38.0	44	68.4

L<sub>1</sub> = approximate length with nut tightened

Please see "Engineering and technical data - Selecting the correct tube fitting" for more information on pressure.

# PIPE SCREW JOINTS

BS WELDING ELBOWS



## BS WELDING ELBOWS

Socket material: steel, fusion weldable.

Socket surface: bright, oiled.

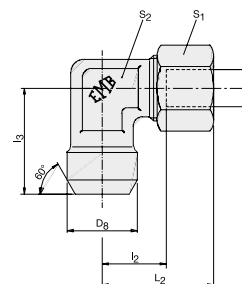

description	pipe OD	PN series	S <sub>1</sub>	S <sub>2</sub>	L <sub>2</sub>	l <sub>2</sub>	l <sub>3</sub>	d <sub>8</sub>	kg / 100 pcs
DS-BS 6-L	6	L 500	14	12	27	12.0	19	10	3.0
DS-BS 8-L	8		17	12	29	14.0	23	12	3.6
DS-BS 10-L	10		19	14	30	15.0	24	14	5.2
DS-BS 12-L	12		22	17	32	17.0	25	16	7.3
DS-BS 15-L	15	L 400	27	19	36	21.0	30	19	12.0
DS-BS 18-L	18		32	24	40	23.5	33	22	16.6
DS-BS 22-L	22	L 250	36	27	44	27.5	37	27	24.6
DS-BS 28-L	28		41	36	47	30.5	42	32	34.7
DS-BS 35-L	35		50	41	56	34.5	49	40	61.2
DS-BS 42-L	42		60	50	63	40.0	57	46	84.6
DS-BS 6-S	6	S 800	17	12	31	16.0	23	11	5.2
DS-BS 8-S	8		19	14	32	17.0	24	13	6.4
DS-BS 10-S	10		22	17	34	17.5	25	15	9.7
DS-BS 12-S	12	S 630	24	17	38	21.5	29	17	10.8
DS-BS 14-S	14		27	19	40	22.0	30	19	15.3
DS-BS 16-S	16		30	24	43	24.5	33	21	18.9
DS-BS 20-S	20	S 400	36	27	48	26.5	37	26	30.3
DS-BS 25-S	25		46	36	54	30.0	42	31	58.0
DS-BS 30-S	30		50	41	62	35.5	49	36	74.4
DS-BS 38-S	38		60	50	72	41.0	57	44	98.9

Please see "Engineering and technical data - Selecting the correct tube fitting" for more information on pressure.



**DRIVEN BY POSSIBILITY™**

# **2. TUBE FITTINGS**

# TUBE FITTINGS

BANJO FITTINGS | SBD BANJO FITTING

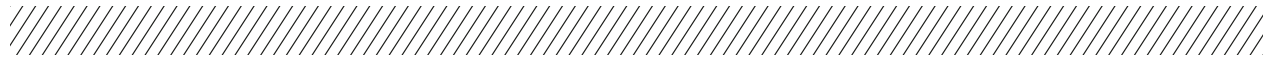

## SBD BANJO FITTING BSP

BSP parallel.

Bodies from forgings with turned sealing shoulder.

Tubes O.D. L 18, L 22, S 16 and S 20 with sealing washer.

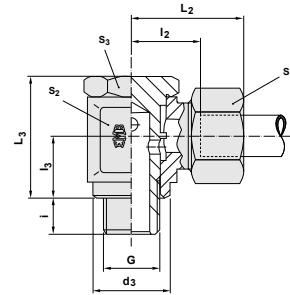

description	pipe OD	PB series	S <sub>1</sub>	S <sub>2</sub>	S <sub>3</sub>	L <sub>2</sub>	l <sub>2</sub>	l <sub>3</sub>	L <sub>3</sub>	d <sub>3</sub>	i	G	MA* Nm	kg / 100 pcs
SBD 4-RLL	4	LL 100	10	14	14	21	11.5	10.0	21.0	14.5	6	G 1/8" A	20	3.0
SBD 6-RLL	6		12	14	14	22	10.0	10.0	21.0	14.5	6	G 1/8" A	20	3.3
SBD 8-RLL	8		14	14	14	23	12.0	10.0	21.0	14.5	6	G 1/8" A	20	3.5
DS-SBD 6-RL	6	L 250	14	14	14	25	10.5	10.0	21.0	14.5	6	G 1/8" A	20	4.0
DS-SBD 8-RL	8		17	19	19	28	13.0	13.0	27.0	18.5	9	G 1/4" A	45	7.7
DS-SBD 10-RL	10		19	19	19	29	14.0	13.0	27.0	18.5	9	G 1/4" A	45	8.5
DS-SBD 12-RL	12	L 160	22	22	22	30	15.5	15.0	32.0	22.5	9	G 3/8" A	70	14.2
DS-SBD 15-RL	15		27	27	27	34	19.0	18.0	37.5	26.5	11	G 1/2" A	100	19.5
DS-SBD 18-RL	18		32	30	27	37	20.5	21.5	44.0	26.0	11	G 1/2" A	100	20.5
DS-SBD 22-RL	22	S 250	36	36	32	42	25.5	24.0	49.0	32.0	13	G 3/4" A	140	38.3
DS-SBD 6-RS	6		17	19	19	30	15.0	13.0	27.0	18.5	9	G 1/4" A	45	8.0
DS-SBD 8-RS	8		19	19	19	30	15.0	13.0	27.0	18.5	9	G 1/4" A	45	9.5
DS-SBD 10-RS	10	S 160	22	22	22	32	16.0	15.0	32.0	22.5	9	G 3/8" A	70	12.0
DS-SBD 12-RS	12		24	24	24	33	17.0	18.0	37.0	22.5	9	G 3/8" A	70	14.5
DS-SBD 14-RS	14		27	27	27	38	20.0	18.0	37.0	26.5	11	G 1/2" A	100	21.5
DS-SBD 16-RS	16	S 160	30	30	27	40	21.5	21.5	44.0	26.0	11	G 1/2" A	100	27.7
DS-SBD 20-RS	20		36	36	32	46	24.5	24.0	49.0	32.0	13	G 3/4" A	140	42.5

L<sub>2</sub> = approximate length with nut tightened

\* Recommended tightening torques for stud threads G, with mating material steel

Please see "Engineering and technical data - Selecting the correct tube fitting" for more information on pressure.

# TUBE FITTINGS

BANJO FITTINGS | SBD BANJO FITTING

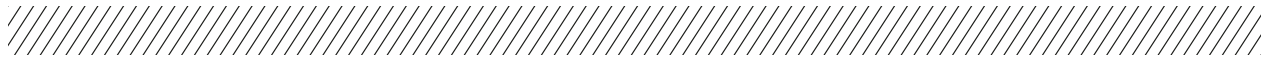

## SBD BANJO FITTING METRIC

Metric parallel.

Bodies from forgings with turned sealing shoulder.

Tubes O.D. L 18, L 22, S 16 and S 20 with sealing washer.

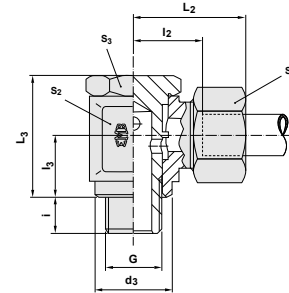

description	pipe OD	PB series	S <sub>1</sub>	S <sub>2</sub>	S <sub>3</sub>	L <sub>2</sub>	l <sub>2</sub>	l <sub>3</sub>	L <sub>3</sub>	d <sub>3</sub>	i	G	MA* Nm	kg / 100 pcs
SBD 4-MLL	4	LL 100	10	12	12	20	10.5	8.0	17.0	12.5	6	M 8x1	10	2.8
SBD 6-MLL	6		12	14	14	22	10.0	10.0	21.0	14.5	6	M 10x1	25	3.3
SBD 8-MLL	8		14	14	14	23	12.0	10.0	21.0	14.5	6	M 10x1	25	3.5
DS-SBD 6-ML	6	L 250	14	14	14	25	10.5	10.0	21.0	14.5	6	M 10x1	25	3.8
DS-SBD 8-ML	8		17	17	17	27	12.0	12.0	25.0	17.5	9	M 12x1.5	40	7.0
DS-SBD 10-ML	10		19	19	19	29	14.0	13.0	27.0	19.5	9	M 14x1.5	55	8.0
DS-SBD 12-ML	12	L 160	22	22	22	30	15.5	15.0	32.0	21.5	9	M 16x1.5	65	11.2
DS-SBD 15-ML	15		27	24	24	33	17.5	18.0	37.5	23.5	9	M 18x1.5	90	16.5
DS-SBD 18-ML	18		32	30	27	37	20.5	21.5	44.0	27.0	11	M 22x1.5	130	26.5
DS-SBD 22-ML	22	S 250	36	36	32	42	25.5	24.0	49.0	31.0	13	M 26x1.5	140	35.0
DS-SBD 6-MS	6		17	17	17	29	14.0	12.0	25.0	17.5	9	M 12x1.5	40	6.7
DS-SBD 8-MS	8		19	19	19	30	15.0	13.0	27.0	19.5	9	M 14x1.5	55	9.3
DS-SBD 10-MS	10	S 160	22	22	22	32	16.0	15.0	32.0	21.5	9	M 16x1.5	65	13.0
DS-SBD 12-MS	12		24	24	24	33	17.0	18.0	37.0	23.5	9	M 18x1.5	90	16.8
DS-SBD 14-MS	14		27	27	27	38	20.0	18.0	37.0	25.5	11	M 20x1.5	120	21.5
DS-SBD 16-MS	16	S 160	30	30	27	40	21.5	21.5	44.0	27.0	11	M 22x1.5	130	27.5
DS-SBD 20-MS	20		36	36	32	46	24.5	24.0	49.0	32.0	13	M 27x2	150	42.5

L<sub>2</sub> = approximate length with nut tightened

\* Recommended tightening torques for stud threads G. with mating material steel

Please see "Engineering and technical data - Selecting the correct tube fitting" for more information on pressure.



# TUBE FITTINGS

BANJO FITTINGS | SBD BANJO FITTING

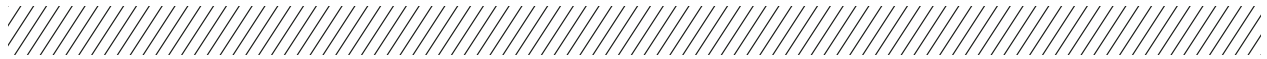

## SBD BANJO FITTING COMPONENTS BSP

BSP parallel.

Order codes single parts.

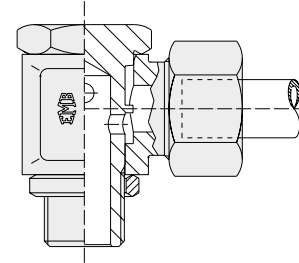

description	pipe OD	series	Housing	Hollow screw	Seal-edge ring
SBD 4-RLL	4	LL	XSBD 4-RLL/K	SHD R 1/8"	turned sealing shoulder
SBD 6-RLL	6		XSBD 6-RLL/K	SHD R 1/8"	turned sealing shoulder
SBD 8-RLL	8		XSBD 8-RLL/K	SHD R 1/8"	turned sealing shoulder
DS-SBD 6-RL	6	L	XSBD 6-RL/K	SHD R 1/8"	turned sealing shoulder
DS-SBD 8-RL	8		XSBD 8-RL/K	SHD R 1/4"	turned sealing shoulder
DS-SBD 10-RL	10		XSBD 10-RL/K	SHD R 1/4"	turned sealing shoulder
DS-SBD 12-RL	12		XSBD 12-RL/K	SHD R 3/8"	turned sealing shoulder
DS-SBD 15-RL	15		XSBD 15-RL/K	SHD R 1/2"	turned sealing shoulder
DS-SBD 18-RL	18		XSBD 18-RL/K	SHD R 1/2" / 55	DKAD R 1/2"
DS-SBD 22-RL	22		XSBD 22-RL/K	SHD R 3/4"	DKAD R 3/4"
DS-SBD 6-RS	6	S	XSBD 6-RS/K	SHD R 1/4"	turned sealing shoulder
DS-SBD 8-RS	8		XSBD 8-RS/K	SHD R 1/4"	turned sealing shoulder
DS-SBD 10-RS	10		XSBD 10-RS/K	SHD R 3/8"	turned sealing shoulder
DS-SBD 12-RS	12		XSBD 12-RS/K	SHD R 3/8" 24	turned sealing shoulder
DS-SBD 14-RS	14		XSBD 14-RS/K	SHD R 1/2"	turned sealing shoulder
DS-SBD 16-RS	16		XSBD 16-RS/K	SHD R 1/2" 55	DKAD R 1/2"
DS-SBD 20-RS	20		XSBD 20-RS/K	SHD R 3/4"	DKAD R 3/4"

Please see "Engineering and technical data - Selecting the correct tube fitting" for more information on pressure.

# TUBE FITTINGS

BANJO FITTINGS | SBD BANJO FITTING

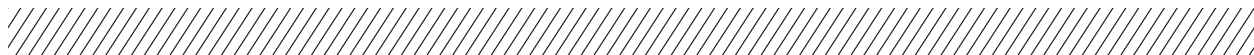

## SBD BANJO FITTING COMPONENTS METRIC

Metric parallel.

Order codes single parts.

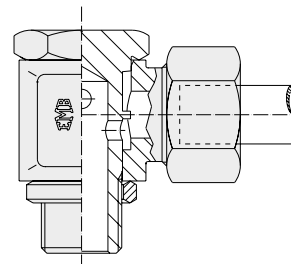

description	pipe OD	series	Housing	Hollow screw	Seal-edge ring
SBD 4-MLL	4	LL	XSBD 4-MLL/K	SHD M 8x1	turned sealing shoulder
SBD 6-MLL	6		XSBD 6-MLL/K	SHD M 10x1	turned sealing shoulder
SBD 8-MLL	8		XSBD 8-MLL/K	SHD M 10x1	turned sealing shoulder
DS-SBD 6-ML	6	L	XSBD 6-ML/K	SHD M 10x1	turned sealing shoulder
DS-SBD 8-ML	8		XSBD 8-ML/K	SHD M 12x1.5	turned sealing shoulder
DS-SBD 10-ML	10		XSBD 10-ML/K	SHD M 14x1.5	turned sealing shoulder
DS-SBD 12-ML	12		XSBD 12-ML/K	SHD M 16x1.5	turned sealing shoulder
DS-SBD 15-ML	15		XSBD 15-ML/K	SHD M 18x1.5	turned sealing shoulder
DS-SBD 18-ML	18		XSBD 18-ML/K	SHD M 22x1.5	DKAD M 22
DS-SBD 22-ML	22	XSBD 22-ML/K	SHD M 26x1.5	DKAD M 26	
DS-SBD 6-MS	6	S	XSBD 6-MS/K	SHD M 12x1.5	turned sealing shoulder
DS-SBD 8-MS	8		XSBD 8-MS/K	SHD M 14x1.5	turned sealing shoulder
DS-SBD 10-MS	10		XSBD 10-MS/K	SHD M 16x1.5	turned sealing shoulder
DS-SBD 12-MS	12		XSBD 12-MS/K	SHD M 18x1.5	turned sealing shoulder
DS-SBD 14-MS	14		XSBD 14-MS/K	SHD M 20x1.5	turned sealing shoulder
DS-SBD 16-MS	16		XSBD 16-MS/K	SHD M 22x1.5	DKAD M 22
DS-SBD 20-MS	20		XSBD 20-MS/K	SHD M 27x2	DKAD M 27

Please see "Engineering and technical data - Selecting the correct tube fitting" for more information on pressure.

# TUBE FITTINGS

BANJO FITTINGS | SB BANJO FITTING CHOKE-FREE



## SB BANJO FITTING CHOKE-FREE BSP

BSP parallel.

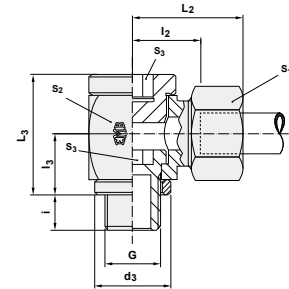

description	pipe OD	PB series	S <sub>1</sub>	S <sub>2</sub>	S <sub>3</sub>	L <sub>2</sub>	l <sub>2</sub>	l <sub>3</sub>	L <sub>3</sub>	d <sub>3</sub>	i	G	kg / 100 pcs	
DS-SB 6-RL	6	L 250	14	18	6	27	12.5	12.0	24	14	8	G 1/8" A	5.9	
DS-SB 8-RL	8		17	22	8	29	14.5	16.0	30	18	12	G 1/4" A	10.5	
DS-SB 10-RL	10		19	22	8	30	15.5	16.0	30	18	12	G 1/4" A	11.3	
DS-SB 12-RL	12		22	27	10	33	18.0	18.0	37	22	12	G 3/8" A	18.0	
DS-SB 15-RL	15		27	32	12	37	22.0	21.0	42	26	14	G 1/2" A	24.7	
DS-SB 18-RL	18		32	36	12	38	21.5	23.0	46	26	14	G 1/2" A	26.9	
DS-SB 22-RL	22	L 100	36	46	17	45	28.5	28.0	58	32	16	G 3/4" A	54.6	
DS-SB 28-RL	28		41	50	22	48	31.5	30.5	64	39	18	G 1" A	83.0	
DS-SB 35-RL	35		50	60	27	57	35.5	36.0	76	49	20	G 1 1/4" A	117.3	
DS-SB 42-RL	42		60	70	32	63	40.0	41.0	85	55	22	G 1 1/2" A	224.4	
DS-SB 6-RS	6		S 400*	17	22	8	31	16.5	16.0	30	18	12	G 1/4" A	10.9
DS-SB 8-RS	8			19	22	8	31	16.5	16.0	30	18	12	G 1/4" A	11.4
DS-SB 10-RS	10	22		27	10	35	18.5	18.0	37	22	12	G 3/8" A	19.0	
DS-SB 12-RS	12	24		27	10	35	18.5	18.0	37	22	12	G 3/8" A	19.6	
DS-SB 14-RS	14	27		32	12	41	23.0	21.0	42	26	14	G 1/2" A	29.7	
DS-SB 16-RS	16	30		36	12	41	22.5	23.0	46	26	14	G 1/2" A	30.7	
DS-SB 20-RS	20	36		46	17	49	27.5	28.0	58	32	16	G 3/4" A	75.3	
DS-SB 25-RS	25	46		50	22	55	31.0	30.5	64	39	18	G 1" A	101.9	
DS-SB 30-RS	30	S 250*	50	60	27	63	36.5	36.0	76	49	20	G 1 1/4" A	158.0	
DS-SB 38-RS	38		60	70	32	72	41.0	41.0	85	55	22	G 1 1/2" A	243.2	

L<sub>2</sub> = approximate length with nut tightened

\* Security factor minimum 1.6

Please see "Engineering and technical data - Selecting the correct tube fitting" for more information on pressure.

# TUBE FITTINGS

BANJO FITTINGS | SB BANJO FITTING CHOKE-FREE

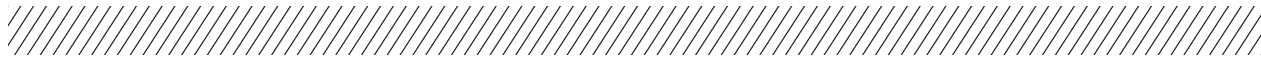

## SB BANJO FITTING CHOKE-FREE METRIC

Metric parallel.

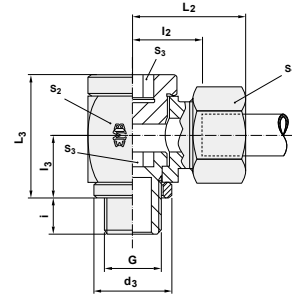

description	pipe OD	PB series	S <sub>1</sub>	S <sub>2</sub>	S <sub>3</sub>	L <sub>2</sub>	L <sub>2</sub>	L <sub>3</sub>	L <sub>3</sub>	d <sub>3</sub>	i	G	kg / 100 pcs	
DS-SB 6-ML	6	L 250	14	18	6	27	12.5	12.0	24	14	8	M 10x1	6.2	
DS-SB 8-ML	8		17	22	6	29	14.5	15.0	30	17	12	M 12x1.5	10.0	
DS-SB 10-ML	10		19	22	8	30	15.5	16.0	30	19	12	M 14x1.5	11.4	
DS-SB 12-ML	12		22	27	10	33	18.0	18.0	37	21	12	M 16x1.5	17.9	
DS-SB 15-ML	15		27	30	12	36	21.0	20.0	40	23	12	M 18x1.5	24.1	
DS-SB 18-ML	18		32	36	14	38	21.5	23.0	46	27	14	M 22x1.5	30.1	
DS-SB 22-ML	22	L 100	36	41	17	42	26.0	25.0	51	31	16	M 26x1.5	39.9	
DS-SB 28-ML	28		41	50	22	48	31.5	30.5	64	39	18	M 33x2	82.5	
DS-SB 35-ML	35		50	60	27	57	35.5	36.0	76	49	20	M 42x2	116.1	
DS-SB 42-ML	42		60	70	32	63	40.0	41.0	85	55	22	M 48x2	224.0	
DS-SB 6-MS	6		S 400*	17	22	6	31	16.5	15.0	30	17	12	M 12x1.5	9.2
DS-SB 8-MS	8			19	22	8	31	16.5	16.0	30	19	12	M 14x1.5	11.6
DS-SB 10-MS	10	22		27	10	35	18.5	18.0	37	21	12	M 16x1.5	18.9	
DS-SB 12-MS	12	24		30	12	37	20.5	20.0	41	23	12	M 18x1.5	24.0	
DS-SB 14-MS	14	27		32	12	41	23.0	21.0	42	25	14	M 20x1.5	30.2	
DS-SB 16-MS	16	30		36	14	41	22.5	23.0	46	27	14	M 22x1.5	38.9	
DS-SB 20-MS	20	S 250*	36	46	17	49	27.5	28.0	58	32	16	M 27x2	75.8	
DS-SB 25-MS	25		46	50	22	55	31.0	30.5	64	39	18	M 33x2	101.4	
DS-SB 30-MS	30		50	60	27	63	36.5	36.0	76	49	20	M 42x2	156.8	
DS-SB 38-MS	38		60	70	32	72	41.0	41.0	85	55	22	M 48x2	242.8	

L<sub>2</sub> = approximate length with nut tightened

\* Security factor minimum 1.6

Please see "Engineering and technical data - Selecting the correct tube fitting" for more information on pressure.

# TUBE FITTINGS

BANJO FITTINGS | SBE BANJO FITTING HIGH PRESSURE

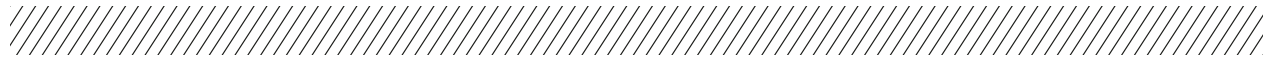

## SBE BANJO FITTING HIGH PRESSURE BSP DKA

BSP parallel.

Edge sealing ring DKA match "narrow" counter bore according to DIN 3852/d4.

O-ring NBR (e.g. Perbunan), FKM (e.g. Viton) upon request.

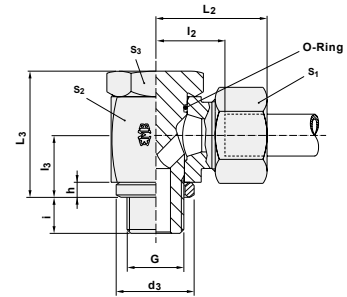

description	pipe OD	PB series	S <sub>1</sub>	S <sub>2</sub>	S <sub>3</sub>	L <sub>2</sub>	L <sub>2</sub>	L <sub>3</sub>	L <sub>3</sub>	d <sub>3</sub>	i	h	G	MA* Nm	kg / 100 pcs
DS-SBE 6-RL	6	L 500	14	17	17	27	24	12.0	10.5	14	8	2.5	G 1/8" A	20	6.4
DS-SBE 8-RL	8		17	22	19	29	30	14.5	14.0	18	12	3.0	G 1/4" A	50	11.7
DS-SBE 10-RL	10		19	22	19	30	30	15.5	14.0	18	12	3.0	G 1/4" A	50	12.3
DS-SBE 12-RL	12	L 400	22	27	24	33	36	18.0	16.5	22	12	3.0	G 3/8" A	75	20.7
DS-SBE 15-RL	15		27	32	30	37	45	21.5	21.5	26	14	4.5	G 1/2" A	130	35.9
DS-SBE 18-RL	18		32	32	30	37	45	21.0	21.5	26	14	4.5	G 1/2" A	130	38.4
DS-SBE 22-RL	22	L 250	36	41	36	44	53	27.5	24.0	32	16	3.5	G 3/4" A	250	66.6
DS-SBE 28-RL	28		41	50	46	49	66	32.0	30.5	39	18	3.5	G 1" A	350	112.7
DS-SBE 35-RL	35		50	60	55	58	76	36.0	35.5	49	20	3.5	G 1 1/4" A	600	166.3
DS-SBE 42-RL	42	S 500	60	70	60	63	87	40.5	40.5	55	22	3.5	G 1 1/2" A	800	245.9
DS-SBE 6-RS	6		17	22	19	31	30	16.5	14.0	18	12	3.0	G 1/4" A	50	12.6
DS-SBE 8-RS	8		19	22	19	31	30	16.5	14.0	18	12	3.0	G 1/4" A	50	12.9
DS-SBE 10-RS	10	S 400	22	27	24	35	36	18.5	16.5	22	12	3.0	G 3/8" A	75	22.0
DS-SBE 12-RS	12		24	27	24	35	36	18.5	16.5	22	12	3.0	G 3/8" A	75	22.5
DS-SBE 14-RS	14		27	32	30	40	45	22.5	21.5	26	14	4.5	G 1/2" A	130	37.5
DS-SBE 16-RS	16	S 400	30	32	30	40	45	22.0	21.5	26	14	4.5	G 1/2" A	130	39.3
DS-SBE 20-RS	20		36	41	36	48	53	26.5	24.0	32	16	3.5	G 3/4" A	250	69.2
DS-SBE 25-RS	25		46	50	46	56	66	31.5	30.5	39	18	3.5	G 1" A	350	128.4
DS-SBE 30-RS	30	S 400	50	60	55	64	76	37.0	35.5	49	20	3.5	G 1 1/4" A	600	176.3
DS-SBE 38-RS	38		60	70	60	72	87	41.5	40.5	55	22	3.5	G 1 1/2" A	800	293.0

L<sub>2</sub> = approximate length with nut tightened

\* Recommended tightening torques for stud threads G. with mating material steel

Please see "Engineering and technical data - Selecting the correct tube fitting" for more information on pressure.

# TUBE FITTINGS

BANJO FITTINGS | SBE BANJO FITTING HIGH PRESSURE



## SBE BANJO FITTING HIGH PRESSURE BSP EDE

BSP parallel.

Sealing ring EDE (vulcanised NBR) for "narrow" DIN 3852/d4 bore.

O-ring NBR (e.g. Perbunan), FKM (e.g. Viton) upon request.

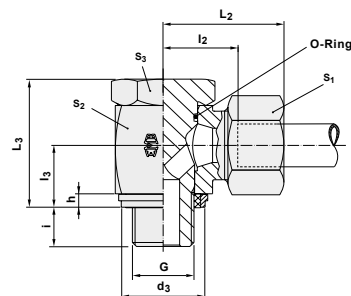

description	pipe OD	PB series	S <sub>1</sub>	S <sub>2</sub>	S <sub>3</sub>	L <sub>2</sub>	l <sub>2</sub>	l <sub>3</sub>	L <sub>3</sub>	D <sub>9</sub>	i	h	G	MA* Nm	kg / 100 pcs
DS-SBE 6-RL/EDE	6	L 500	14	17	17	27	12.0	24	10.5	14.9	8	2.5	G 1/8" A	20	6.4
DS-SBE 8-RL/EDE	8		17	22	19	29	14.5	30	14.0	18.9	12	3.0	G 1/4" A	50	11.7
DS-SBE 10-RL/EDE	10		19	22	19	30	15.5	30	14.0	18.9	12	3.0	G 1/4" A	50	12.3
DS-SBE 12-RL/EDE	12	L 400	22	27	24	33	18.0	36	16.5	21.9	12	3.0	G 3/8" A	75	20.7
DS-SBE 15-RL/EDE	15		27	32	30	37	21.5	45	21.5	26.9	14	4.5	G 1/2" A	130	35.9
DS-SBE 18-RL/EDE	18		32	32	30	37	21.0	45	21.5	26.9	14	4.5	G 1/2" A	130	38.4
DS-SBE 22-RL/EDE	22	L 250	36	41	36	44	27.5	53	24.0	32.9	16	3.5	G 3/4" A	250	66.6
DS-SBE 28-RL/EDE	28		41	50	46	49	32.0	66	30.5	39.9	18	3.5	G 1" A	350	112.7
DS-SBE 35-RL/EDE	35		50	60	55	58	36.0	76	35.5	49.9	20	3.5	G 1 1/4" A	600	166.3
DS-SBE 42-RL/EDE	42	S 500	60	70	60	63	40.5	87	40.5	55.9	22	3.5	G 1 1/2" A	800	245.9
DS-SBE 6-RS/EDE	6		17	22	19	31	16.5	30	14.0	18.9	12	3.0	G 1/4" A	50	12.6
DS-SBE 8-RS/EDE	8		19	22	19	31	16.5	30	14.0	18.9	12	3.0	G 1/4" A	50	12.9
DS-SBE 10-RS/EDE	10	S 400	22	27	24	35	18.5	36	16.5	21.9	12	3.0	G 3/8" A	75	22.0
DS-SBE 12-RS/EDE	12		24	27	24	35	18.5	36	16.5	21.9	12	3.0	G 3/8" A	75	22.5
DS-SBE 14-RS/EDE	14		27	32	30	40	22.5	45	21.5	26.9	14	4.5	G 1/2" A	130	37.5
DS-SBE 16-RS/EDE	16	S 400	30	32	30	40	22.0	45	21.5	26.9	14	4.5	G 1/2" A	130	39.3
DS-SBE 20-RS/EDE	20		36	41	36	48	26.5	53	24.0	32.9	16	3.5	G 3/4" A	250	69.2
DS-SBE 25-RS/EDE	25		46	50	46	56	31.5	66	30.5	39.9	18	3.5	G 1" A	350	128.4
DS-SBE 30-RS/EDE	30	S 400	50	60	55	64	37.0	76	35.5	49.9	20	3.5	G 1 1/4" A	600	176.3
DS-SBE 38-RS/EDE	38		60	70	60	72	41.5	87	40.5	55.9	22	3.5	G 1 1/2" A	800	293.0

L<sub>2</sub> = approximate length with nut tightened

\* Recommended tightening torques for stud threads G. with mating material steel

Please see "Engineering and technical data - Selecting the correct tube fitting" for more information on pressure.

# TUBE FITTINGS

BANJO FITTINGS | SBE BANJO FITTING HIGH PRESSURE

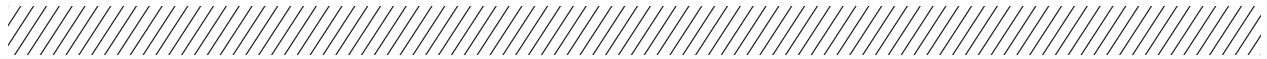

## SBE BANJO FITTING HIGH PRESSURE BSP KDE

BSP parallel.

Metal joint ring KDE.

O-ring NBR (e.g. Perbunan), FKM (e.g. Viton) upon request.

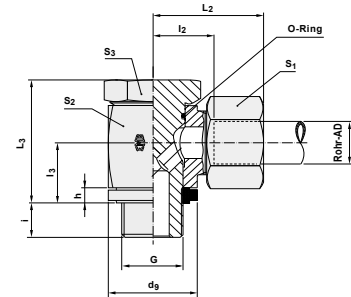

description	pipe OD	PB series	S <sub>1</sub>	S <sub>2</sub>	S <sub>3</sub>	L <sub>2</sub>	l <sub>2</sub>	l <sub>3</sub>	L <sub>3</sub>	D <sub>9</sub>	i	h	G	MA* Nm	kg / 100 pcs
DS-SBE 6-RL/KDE	6	L 500	14	17	17	27	12.0	10.5	24	17	8	2.5	G 1/8" A	20	6.4
DS-SBE 8-RL/KDE	8		17	22	19	29	14.5	14.0	30	22	12	3.0	G 1/4" A	50	11.9
DS-SBE 10-RL/KDE	10		19	22	19	30	15.5	14.0	30	22	12	3.0	G 1/4" A	50	12.5
DS-SBE 12-RL/KDE	12	L 400	22	27	24	33	18.0	16.5	36	27	12	3.0	G 3/8" A	75	21.0
DS-SBE 15-RL/KDE	15		27	32	30	37	21.5	21.5	45	32	14	4.5	G 1/2" A	130	36.5
DS-SBE 18-RL/KDE	18		32	32	30	37	21.0	21.5	45	32	14	4.5	G 1/2" A	130	39.0
DS-SBE 22-RL/KDE	22	L 250	36	41	36	44	27.5	24.0	53	41	16	3.5	G 3/4" A	250	67.7
DS-SBE 28-RL/KDE	28		41	50	46	49	32.0	30.5	66	46	18	3.5	G 1" A	350	113.5
DS-SBE 35-RL/KDE	35		50	60	55	58	36.0	35.5	76	57	20	3.5	G 1 1/4" A	600	167.7
DS-SBE 42-RL/KDE	42	S 500	60	70	60	63	40.5	40.5	87	64	22	3.5	G 1 1/2" A	800	247.7
DS-SBE 6-RS/KDE	6		17	22	19	31	16.5	14.0	30	22	12	3.0	G 1/4" A	50	12.7
DS-SBE 8-RS/KDE	8		19	22	19	31	16.5	14.0	30	22	12	3.0	G 1/4" A	50	13.1
DS-SBE 10-RS/KDE	10	S 400	22	27	24	35	18.5	16.5	36	27	12	3.0	G 3/8" A	75	22.2
DS-SBE 12-RS/KDE	12		24	27	24	35	18.5	16.5	36	27	12	3.0	G 3/8" A	75	22.8
DS-SBE 14-RS/KDE	14		27	32	30	40	22.5	21.5	45	32	14	4.5	G 1/2" A	130	38.0
DS-SBE 16-RS/KDE	16	S 400	30	32	30	40	22.0	21.5	45	32	14	4.5	G 1/2" A	130	39.9
DS-SBE 20-RS/KDE	20		36	41	36	48	26.5	24.0	53	41	16	3.5	G 3/4" A	250	70.3
DS-SBE 25-RS/KDE	25		46	50	46	56	31.5	30.5	66	46	18	3.5	G 1" A	350	129.2
DS-SBE 30-RS/KDE	30	S 400	50	60	55	64	37.0	35.5	76	57	20	3.5	G 1 1/4" A	600	177.7
DS-SBE 38-RS/KDE	38		60	70	60	72	41.5	40.5	87	64	22	3.5	G 1 1/2" A	800	294.8

L<sub>2</sub> = approximate length with nut tightened

\* Recommended tightening torques for stud threads G. with mating material steel

Please see "Engineering and technical data - Selecting the correct tube fitting" for more information on pressure.

# TUBE FITTINGS

BANJO FITTINGS | SBE BANJO FITTING HIGH PRESSURE



## SBE BANJO FITTING HIGH PRESSURE METRIC DKA

Metric parallel.

Edge sealing ring DKA match “narrow” counter bore according to DIN 3852/d4.

O-ring NBR (e.g. Perbunan), FKM (e.g. Viton) upon request.

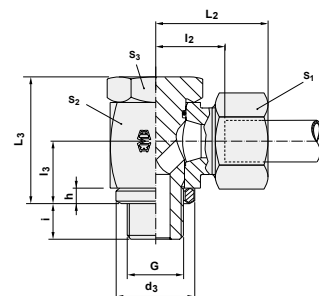

description	pipe OD	PB series	S <sub>1</sub>	S <sub>2</sub>	S <sub>3</sub>	L <sub>2</sub>	l <sub>2</sub>	l <sub>3</sub>	L <sub>3</sub>	d <sub>3</sub>	i	h	G	MA* Nm	kg / 100 pcs
DS-SBE 6-ML	6	L 500	14	17	17	27	12.0	10.5	24.0	14	8	2.5	M 10x1	25	6.5
DS-SBE 8-ML	8		17	22	19	29	14.5	14.0	30.0	17	12	3.0	M 12x1.5	50	11.4
DS-SBE 10-ML	10		19	22	19	30	15.5	14.0	30.0	19	12	3.0	M 14x1.5	60	12.5
DS-SBE 12-ML	12	L 400	22	27	24	33	18.0	16.5	36.0	21	12	3.0	M 16x1.5	90	20.3
DS-SBE 15-ML	15		27	30	27	36	20.5	18.5	39.5	23	12	3.0	M 18x1.5	110	28.8
DS-SBE 18-ML	18		32	32	30	37	21.0	21.5	45.0	27	14	4.5	M 22x1.5	150	38.8
DS-SBE 22-ML	22	L 250	36	41	36	44	27.5	24.0	53.0	31	16	3.5	M 26x1.5	350	65.8
DS-SBE 28-ML	28		41	50	46	49	32.0	30.5	66.0	39	18	3.5	M 33x2	400	110.3
DS-SBE 35-ML	35		50	60	55	58	36.0	35.5	76.0	49	20	3.5	M 42x2	600	166.3
DS-SBE 42-ML	42	S 500	60	70	60	63	40.5	40.5	87.0	55	22	3.5	M 48x2	800	249.9
DS-SBE 6-MS	6		17	22	19	31	16.5	14.0	30.0	17	12	3.0	M 12x1.5	50	12.2
DS-SBE 8-MS	8		19	22	19	31	16.5	14.0	30.0	19	12	3.0	M 14x1.5	60	13.2
DS-SBE 10-MS	10	S 400	22	27	24	35	18.5	16.5	36.0	21	12	3.0	M 16x1.5	90	21.7
DS-SBE 12-MS	12		24	30	27	36	20.0	18.5	39.5	23	12	3.0	M 18x1.5	110	28.0
DS-SBE 14-MS	14		27	32	30	40	22.5	20.0	48.5	25	14	3.0	M 20x1.5	130	37.4
DS-SBE 16-MS	16	S 400	30	32	30	40	22.0	21.5	45.0	27	14	4.5	M 22x1.5	150	39.4
DS-SBE 20-MS	20		36	41	36	48	26.5	24.0	53.0	32	16	3.5	M 27x2	350	68.8
DS-SBE 25-MS	25		46	50	46	56	31.5	30.5	66.0	39	18	3.5	M 33x2	400	126.0
DS-SBE 30-MS	30	S 400	50	60	55	64	37.0	35.5	76.0	49	20	3.5	M 42x2	600	176.3
DS-SBE 38-MS	38		60	70	60	72	41.5	40.5	87.0	55	22	3.5	M 48x2	800	296.9

L<sub>2</sub> = approximate length with nut tightened

\* Recommended tightening torques for stud threads G. with mating material steel

Please see “Engineering and technical data - Selecting the correct tube fitting” for more information on pressure.



# TUBE FITTINGS

BANJO FITTINGS | SBE BANJO FITTING HIGH PRESSURE



## SBE BANJO FITTING HIGH PRESSURE METRIC EDE

Metric parallel.

Sealing ring EDE (vulcanised NBR) for "narrow"  
DIN 3852/d4 bore.

O-ring NBR (e.g. Perbunan), FKM (e.g. Viton)  
upon request.

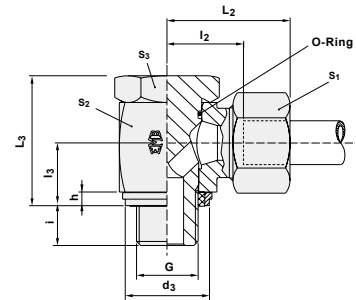

description	pipe OD	PB series	S <sub>1</sub>	S <sub>2</sub>	S <sub>3</sub>	L <sub>2</sub>	l <sub>2</sub>	l <sub>3</sub>	L <sub>3</sub>	d <sub>3</sub>	i	h	d <sub>9</sub>	G	MA* Nm	kg / 100 pcs
DS-SBE 6-ML/EDE	6	L 500	14	17	17	27	12.0	10.5	24.0	14.9	8	2.5	8	M 10x1	25	6.6
DS-SBE 8-ML/EDE	8		17	22	19	29	14.5	14.0	30.0	16.9	12	3.0	12	M 12x1.5	50	11.6
DS-SBE 10-ML/EDE	10		19	22	19	30	15.5	14.0	30.0	18.9	12	3.0	12	M 14x1.5	60	12.7
DS-SBE 12-ML/EDE	12	L 400	22	27	24	33	18.0	16.5	36.0	21.9	12	3.0	12	M 16x1.5	90	20.7
DS-SBE 15-ML/EDE	15		27	30	27	36	20.5	18.5	39.5	23.9	12	3.0	12	M 18x1.5	110	28.8
DS-SBE 18-ML/EDE	18		32	32	30	37	21.0	21.5	45.0	26.9	14	4.5	14	M 22x1.5	150	39.3
DS-SBE 22-ML/EDE	22	L 250	36	41	36	44	27.5	24.0	53.0	31.9	16	3.5	16	M 26x1.5	350	67.0
DS-SBE 28-ML/EDE	28		41	50	46	49	32.0	30.5	66.0	39.9	18	3.5	18	M 33x2	400	111.1
DS-SBE 35-ML/EDE	35		50	60	55	58	36.0	35.5	76.0	49.9	20	3.5	20	M 42x2	600	167.7
DS-SBE 42-ML/EDE	42	S 500	60	70	60	63	40.5	40.5	87.0	55.9	22	3.5	22	M 48x2	800	251.7
DS-SBE 6-MS/EDE	6		17	22	19	31	16.5	14.0	30.0	16.9	12	3.0	12	M 12x1.5	50	12.5
DS-SBE 8-MS/EDE	8		19	22	19	31	16.5	14.0	30.0	18.9	12	3.0	12	M 14x1.5	60	13.3
DS-SBE 10-MS/EDE	10	S 400	22	27	24	35	18.5	16.5	36.0	21.9	12	3.0	12	M 16x1.5	90	22.0
DS-SBE 12-MS/EDE	12		24	30	27	36	20.0	18.5	39.5	23.9	12	3.0	12	M 18x1.5	110	28.3
DS-SBE 16-MS/EDE	16		30	32	30	40	22.0	21.5	45.0	26.9	14	4.5	14	M 22x1.5	150	39.8
DS-SBE 20-MS/EDE	20	S 400	36	41	36	48	26.5	24.0	53.0	32.9	16	3.5	16	M 27x2	350	69.9
DS-SBE 25-MS/EDE	25		46	50	46	56	31.5	39.0	66.0	39.9	18	3.5	18	M 33x2	400	126.8
DS-SBE 30-MS/EDE	30		50	60	55	64	37.0	49.0	76.0	49.9	20	3.5	20	M 42x2	600	177.6
DS-SBE 38-MS/EDE	38		60	70	60	72	41.5	55.0	87.0	55.9	22	3.5	22	M 48x2	800	298.7

L<sub>2</sub> = approximate length with nut tightened

\* Recommended tightening torques for stud threads G. with mating material steel

Please see "Engineering and technical data - Selecting the correct tube fitting" for more information on pressure.

# TUBE FITTINGS

BANJO FITTINGS | SBE BANJO FITTING HIGH PRESSURE

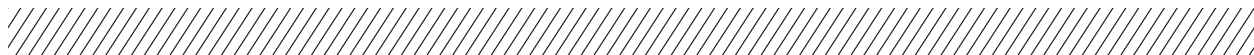

## SBE BANJO FITTING HIGH PRESSURE METRIC KDE

Metric parallel.

Metal joint ring KDE.

O-ring NBR (e.g. Perbunan), FKM (e.g. Viton) upon request.

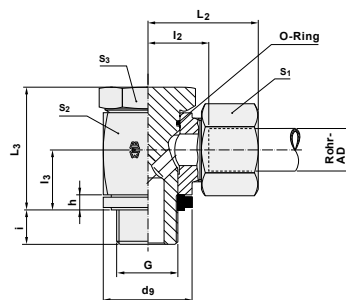

description	pipe OD	PB series	S <sub>1</sub>	S <sub>2</sub>	S <sub>3</sub>	L <sub>2</sub>	l <sub>2</sub>	l <sub>3</sub>	L <sub>3</sub>	d <sub>3</sub>	h	d <sub>9</sub>	G	MA* Nm	kg / 100 pcs
DS-SBE 6-ML/KDE	6	L 500	14	17	17	27	12.0	10.5	24.0	17	2.5	8	M 10x1	25	6.6
DS-SBE 8-ML/KDE	8		17	22	19	29	14.5	14.0	30.0	22	3.0	12	M 12x1.5	50	11.6
DS-SBE 10-ML/KDE	10		19	22	19	30	15.5	14.0	30.0	23	3.0	12	M 14x1.5	60	12.7
DS-SBE 12-ML/KDE	12	L 400	22	27	24	33	18.0	16.5	36.0	27	3.0	12	M 16x1.5	90	20.7
DS-SBE 15-ML/KDE	15		27	30	27	36	20.5	18.5	39.5	29	3.0	12	M 18x1.5	110	28.8
DS-SBE 18-ML/KDE	18		32	32	30	37	21.0	21.5	45.0	32	4.5	14	M 22x1.5	150	39.3
DS-SBE 22-ML/KDE	22	L 250	36	41	36	44	27.5	24.0	53.0	41	3.5	16	M 26x1.5	350	67.0
DS-SBE 28-ML/KDE	28		41	50	46	49	32.0	30.5	66.0	46	3.5	18	M 33x2	400	111.1
DS-SBE 35-ML/KDE	35		50	60	55	58	36.0	35.5	76.0	57	3.5	20	M 42x2	600	167.7
DS-SBE 42-ML/KDE	42	S 500	60	70	60	63	40.5	40.5	87.0	64	3.5	22	M 48x2	800	251.7
DS-SBE 6-MS/KDE	6		17	22	19	31	16.5	14.0	30.0	22	3.0	12	M 12x1.5	50	12.5
DS-SBE 8-MS/KDE	8		19	22	19	31	16.5	14.0	30.0	23	3.0	12	M 14x1.5	60	13.3
DS-SBE 10-MS/KDE	10	S 400	22	27	24	35	18.5	16.5	36.0	27	3.0	12	M 16x1.5	90	22.0
DS-SBE 12-MS/KDE	12		24	30	27	36	20.0	18.5	39.5	29	3.0	12	M 18x1.5	110	28.3
DS-SBE 16-MS/KDE	16		30	32	30	40	22.0	21.5	45.0	32	4.5	14	M 22x1.5	150	39.8
DS-SBE 20-MS/KDE	20	S 400	36	41	36	48	26.5	24.0	53.0	41	3.5	16	M 27x2	350	69.9
DS-SBE 25-MS/KDE	25		46	50	46	56	31.5	30.5	66.0	46	3.5	18	M 33x2	400	126.8
DS-SBE 30-MS/KDE	30		50	60	55	64	37.0	35.5	76.0	57	3.5	20	M 42x2	600	177.6
DS-SBE 38-MS/KDE	38		60	70	60	72	41.5	40.5	87.0	64	3.5	22	M 48x2	800	298.7

L<sub>2</sub> = approximate length with nut tightened

\* Recommended tightening torques for stud threads G. with mating material steel

Please see "Engineering and technical data - Selecting the correct tube fitting" for more information on pressure.

# TUBE FITTINGS

BANJO FITTINGS | SGE T SWIVELING SCREW FITTING HIGH PRESSURE



## SGE T SWIVELING SCREW FITTING HIGH PRESSURE BSP DKA

BSP parallel.

Edge sealing ring DKA.

O-ring NBR (e.g. Perbunan), FKM (e.g. Viton) upon request.

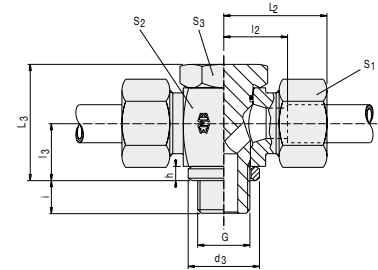

description	pipe OD	PB series	S <sub>1</sub>	S <sub>2</sub>	S <sub>3</sub>	L <sub>2</sub>	l <sub>2</sub>	l <sub>3</sub>	L <sub>3</sub>	d <sub>3</sub>	i	h	d <sub>9</sub>	G	MA* Nm	kg / 100 pcs
DS-SGE 6-RL	6	L 500	14	17	17	27	12.0	10.5	24	14	8	2.5	14.9	G 1/8"A	20	8.0
DS-SGE 8-RL	8		17	22	19	29	14.5	14.0	30	18	12	3.0	18.9	G 1/4"A	50	14.1
DS-SGE 10-RL	10		19	22	19	30	15.5	14.0	30	18	12	3.0	18.9	G 1/4"A	50	15.0
DS-SGE 12-RL	12	L 400	22	27	24	33	18.0	16.5	36	22	12	3.0	21.9	G 3/8"A	75	24.1
DS-SGE 15-RL	15		27	32	30	37	21.5	21.5	45	26	14	4.5	26.9	G 1/2"A	130	40.9
DS-SGE 18-RL	18		32	32	30	37	21.0	21.5	45	26	14	4.5	26.9	G 1/2"A	130	45.8
DS-SGE 22-RL	22	L 250	36	41	36	44	27.5	24.0	53	32	16	3.5	32.9	G 3/4"A	250	75.9
DS-SGE 28-RL	28		41	50	46	49	32.0	30.5	66	39	18	3.5	39.9	G 1" A	350	125.4
DS-SGE 35-RL	35		50	60	55	58	36.0	35.5	76	49	20	3.5	49.9	G 1 1/4"A	600	206.1
DS-SGE 42-RL	42	S 500	60	70	60	63	40.5	40.5	87	55	22	3.5	55.9	G 1 1/2"A	800	299.0
DS-SGE 6-RS	6		17	22	19	31	16.5	14.0	30	18	12	3.0	18.9	G 1/4"A	50	15.2
DS-SGE 8-RS	8		19	22	19	31	16.5	14.0	30	18	12	3.0	18.9	G 1/4"A	50	16.4
DS-SGE 10-RS	10		22	27	24	35	18.5	16.5	36	22	12	3.0	21.9	G 3/8"A	75	26.4
DS-SGE 12-RS	12		24	27	24	35	18.5	16.5	36	22	12	3.0	21.9	G 3/8"A	75	27.8
DS-SGE 14-RS	14		27	32	30	40	22.5	21.5	45	26	14	4.5	26.9	G 1/2"A	130	(37.5)
DS-SGE 16-RS	16		30	32	30	40	22.0	21.5	45	26	14	4.5	26.9	G 1/2"A	130	49.0
DS-SGE 20-RS	20	S 400	36	41	36	48	26.5	24.0	53	32	16	3.5	32.9	G 3/4"A	250	84.2
DS-SGE 25-RS	25		46	50	46	56	31.5	30.5	66	39	18	3.5	39.9	G 1" A	350	155.0
DS-SGE 30-RS	30		50	60	55	64	37.0	35.5	76	49	20	3.5	49.9	G 1 1/4"A	600	230.0
DS-SGE 38-RS	38	60	70	60	72	41.5	40.5	87	55	22	3.5	55.9	G 1 1/2"A	800	337.2	

L<sub>2</sub> = approximate length with nut tightened

\* Recommended tightening torques for stud threads G. with mating material steel

Please see "Engineering and technical data - Selecting the correct tube fitting" for more information on pressure.

# TUBE FITTINGS

BANJO FITTINGS | SGE T SWIVELING SCREW FITTING HIGH PRESSURE



## SGE T SWIVELING SCREW FITTING HIGH PRESSURE BSP EDE

BSP parallel.

Sealing ring EDE.

O-ring NBR (e.g. Perbunan), FKM (e.g. Viton) upon request.

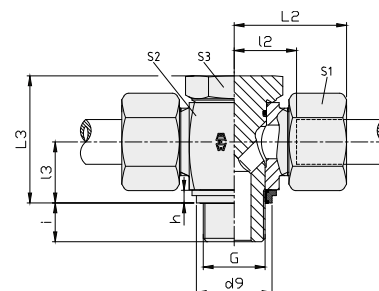

description	pipe OD	PB series	S <sub>1</sub>	S <sub>2</sub>	S <sub>3</sub>	L <sub>2</sub>	l <sub>2</sub>	l <sub>3</sub>	L <sub>3</sub>	i	h	d <sub>9</sub>	G	MA* Nm	kg / 100 pcs
DS-SGE 6-RL/EDE	6	L 500	14	17	17	27	12.0	10.5	24	8	2.5	14.9	G 1/8"A	20	8.1
DS-SGE 8-RL/EDE	8		17	22	19	29	14.5	14.0	30	12	3.0	18.9	G 1/4"A	50	14.2
DS-SGE 10-RL/EDE	10		19	22	19	30	15.5	14.0	30	12	3.0	18.9	G 1/4"A	50	15.2
DS-SGE 12-RL/EDE	12	L 400	22	27	24	33	18.0	16.5	36	12	3.0	21.9	G 3/8"A	75	24.3
DS-SGE 15-RL/EDE	15		27	32	30	37	21.5	21.5	45	14	4.5	26.9	G 1/2"A	130	41.5
DS-SGE 18-RL/EDE	18		32	32	30	37	21.0	21.5	45	14	4.5	26.9	G 1/2"A	130	46.4
DS-SGE 22-RL/EDE	22	L 250	36	41	36	44	27.5	24.0	53	16	3.5	32.9	G 3/4"A	250	77.0
DS-SGE 28-RL/EDE	28		41	50	46	49	32.0	30.5	66	18	3.5	39.9	G 1" A	350	126.2
DS-SGE 35-RL/EDE	35		50	60	55	58	36.0	35.5	76	20	3.5	49.9	G 1 1/4"A	600	207.4
DS-SGE 42-RL/EDE	42	S 500	60	70	60	63	40.5	40.5	87	22	3.5	55.9	G 1 1/2"A	800	300.8
DS-SGE 6-RS/EDE	6		17	22	19	31	16.5	14.0	30	12	3.0	18.9	G 1/4"A	50	15.3
DS-SGE 8-RS/EDE	8		19	22	19	31	16.5	14.0	30	12	3.0	18.9	G 1/4"A	50	16.6
DS-SGE 10-RS/EDE	10		22	27	24	35	18.5	16.5	36	12	3.0	21.9	G 3/8"A	75	26.7
DS-SGE 12-RS/EDE	12		24	27	24	35	18.5	16.5	36	12	3.0	21.9	G 3/8"A	75	28.1
DS-SGE 14-RS/EDE	14		27	32	30	40	22.5	21.5	45	14	4.5	26.9	G 1/2"A	130	(38.0)
DS-SGE 16-RS/EDE	16		30	32	30	40	22.0	21.5	45	14	4.5	26.9	G 1/2"A	130	49.6
DS-SGE 20-RS/EDE	20		36	41	36	48	26.5	24.0	53	16	3.5	32.9	G 3/4"A	250	85.2
DS-SGE 25-RS/EDE	25	S 400	46	50	46	56	31.5	30.5	66	18	3.5	39.9	G 1" A	350	155.9
DS-SGE 30-RS/EDE	30		50	60	55	64	37.0	35.5	76	20	3.5	49.9	G 1 1/4"A	600	231.4
DS-SGE 38-RS/EDE	38		60	70	60	72	41.5	40.5	87	22	3.5	55.9	G 1 1/2"A	800	339.0

L<sub>2</sub> = approximate length with nut tightened

\* Recommended tightening torques for stud threads G. with mating material steel

Please see "Engineering and technical data - Selecting the correct tube fitting" for more information on pressure.

# TUBE FITTINGS

BANJO FITTINGS | SGE T SWIVELING SCREW FITTING HIGH PRESSURE



## SGE T SWIVELING SCREW FITTING HIGH PRESSURE METRIC DKA

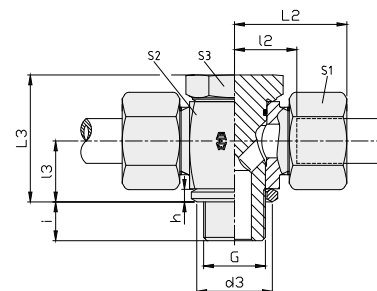

Metric parallel.

Edge sealing ring DKA.

O-ring NBR (e.g. Perbunan), FKM (e.g. Viton) upon request.

description	pipe OD	PB series	S <sub>1</sub>	S <sub>2</sub>	S <sub>3</sub>	L <sub>2</sub>	l <sub>2</sub>	l <sub>3</sub>	L <sub>3</sub>	i	h	d <sub>3</sub>	G	MA* Nm	kg / 100 pcs
DS-SGE 6-ML	6	L 500	14	17	17	27	12.0	10.5	24.0	8	2.5	14.9	M 10x1	25	8.1
DS-SGE 8-ML	8		17	22	19	29	14.5	14.0	30.0	12	3.0	16.9	M 12x1.5	50	13.8
DS-SGE 10-ML	10		19	22	19	30	15.5	14.0	30.0	12	3.0	18.9	M 14x1.5	60	15.3
DS-SGE 12-ML	12	L 400	22	27	24	33	18.0	16.5	36.0	12	3.0	21.9	M 16x1.5	90	23.7
DS-SGE 15-ML	15		27	30	27	36	20.5	18.5	39.5	12	3.0	23.9	M 18x1.5	110	34.3
DS-SGE 18-ML	18		32	32	30	37	21.0	21.5	45.0	14	4.5	26.9	M 22x1.5	150	46.3
DS-SGE 22-ML	22	L 250	36	41	36	44	27.5	24.0	53.0	16	3.5	31.9	M 26x1.5	350	76.0
DS-SGE 28-ML	28		41	50	46	49	32.0	30.5	66.0	18	3.5	39.9	M 33x2	400	122.9
DS-SGE 35-ML	35		50	60	55	58	36.0	35.5	76.0	20	3.5	49.9	M 42x2	600	206.0
DS-SGE 42-ML	42	S 500	60	70	60	63	40.5	40.5	87.0	22	3.5	55.9	M 48x2	800	303.0
DS-SGE 6-MS	6		17	22	19	31	16.5	14.0	30.0	12	3.0	16.9	M 12x1.5	50	14.8
DS-SGE 8-MS	8		19	22	19	31	16.5	14.0	30.0	12	3.0	18.9	M 14x1.5	60	16.6
DS-SGE 10-MS	10	S 400	22	27	24	35	18.5	16.5	36.0	12	3.0	21.9	M 16x1.5	90	26.2
DS-SGE 12-MS	12		24	30	27	36	20.0	18.5	39.5	12	3.0	23.9	M 18x1.5	110	33.1
DS-SGE 14-MS	14		27	32	30	40	22.5	20.0	43.5	14	3.0	-	M 20x1.5	130	(37.4)
DS-SGE 16-MS	16	S 400	30	32	30	40	22.0	21.5	45.0	14	4.5	26.9	M 22x1.5	150	48.7
DS-SGE 20-MS	20		36	41	36	48	26.5	24.0	53.0	16	3.5	32.9	M 27x2	350	83.7
DS-SGE 25-MS	25		46	50	46	56	31.5	30.5	66.0	18	3.5	39.9	M 33x2	400	152.6
DS-SGE 30-MS	30	S 400	50	60	55	64	37.0	35.5	76.0	20	3.5	49.9	M 42x2	600	229.9
DS-SGE 38-MS	38		60	70	60	72	41.5	40.5	87.0	22	3.5	55.9	M 48x2	800	341.2

L<sub>2</sub> = approximate length with nut tightened

\* Recommended tightening torques for stud threads G. with mating material steel

Please see "Engineering and technical data - Selecting the correct tube fitting" for more information on pressure.

# TUBE FITTINGS

BANJO FITTINGS | SGE T SWIVELING SCREW FITTING HIGH PRESSURE



## SGE T SWIVELING SCREW FITTING HIGH PRESSURE METRIC EDE

Metric parallel.

Sealing ring EDE.

O-ring NBR (e.g. Perbunan), FKM (e.g. Viton) upon request.

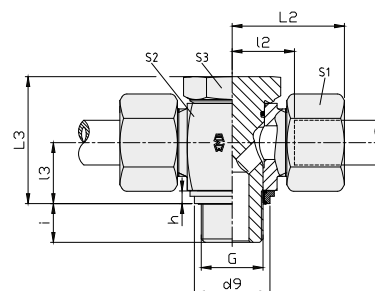

description	pipe OD	PB series	S <sub>1</sub>	S <sub>2</sub>	S <sub>3</sub>	L <sub>2</sub>	l <sub>2</sub>	l <sub>3</sub>	L <sub>3</sub>	i	h	d <sub>9</sub>	G	MA* Nm	kg / 100 pcs
DS-SGE 6-ML/EDE	6	L 500	14	17	17	27	12.0	10.5	24.0	8	2.5	14.9	M 10x1	25	8.1
DS-SGE 8-ML/EDE	8		17	22	19	29	14.5	14.0	30.0	12	3.0	16.9	M 12x1.5	50	14.0
DS-SGE 10-ML/EDE	10		19	22	19	30	15.5	14.0	30.0	12	3.0	18.9	M 14x1.5	60	15.4
DS-SGE 12-ML/EDE	12	L 400	22	27	24	33	18.0	16.5	36.0	12	3.0	21.9	M 16x1.5	90	24.0
DS-SGE 15-ML/EDE	15		27	30	27	36	20.5	18.5	39.5	12	3.0	23.9	M 18x1.5	110	34.7
DS-SGE 18-ML/EDE	18		32	32	30	37	21.0	21.5	45.0	14	4.5	26.9	M 22x1.5	150	46.8
DS-SGE 22-ML/EDE	22	L 250	36	41	36	44	27.5	24.0	53.0	16	3.5	31.9	M 26x1.5	350	77.2
DS-SGE 28-ML/EDE	28		41	50	46	49	32.0	30.5	66.0	18	3.5	39.9	M 33x2	400	123.8
DS-SGE 35-ML/EDE	35		50	60	55	58	36.0	35.5	76.0	20	3.5	49.9	M 42x2	600	207.4
DS-SGE 42-ML/EDE	42	S 500	60	70	60	63	40.5	40.5	87.0	22	3.5	55.9	M 48x2	800	304.8
DS-SGE 6-MS/EDE	6		17	22	19	31	16.5	14.0	30.0	12	3.0	16.9	M 12x1.5	50	15.1
DS-SGE 8-MS/EDE	8		19	22	19	31	16.5	14.0	30.0	12	3.0	18.9	M 14x1.5	60	16.8
DS-SGE 10-MS/EDE	10	S 400	22	27	24	35	18.5	16.5	36.0	12	3.0	21.9	M 16x1.5	90	26.5
DS-SGE 12-MS/EDE	12		24	30	27	36	20.0	18.5	39.5	12	3.0	23.9	M 18x1.5	110	33.5
DS-SGE 16-MS/EDE	16		30	32	30	40	22.0	21.5	45.0	14	4.5	26.9	M 22x1.5	150	49.2
DS-SGE 20-MS/EDE	20	S 400	36	41	36	48	26.5	24.0	53.0	16	3.5	32.9	M 27x2	350	84.8
DS-SGE 25-MS/EDE	25		46	50	46	56	31.5	30.5	66.0	18	3.5	39.9	M 33x2	400	153.5
DS-SGE 30-MS/EDE	30		50	60	55	64	37.0	35.5	76.0	20	3.5	49.9	M 42x2	600	231.3
DS-SGE 38-MS/EDE	38		60	70	60	72	41.5	40.5	87.0	22	3.5	55.9	M 48x2	800	343.0

L<sub>2</sub> = approximate length with nut tightened

\* Recommended tightening torques for stud threads G. with mating material steel

Please see "Engineering and technical data - Selecting the correct tube fitting" for more information on pressure.

# TUBE FITTINGS

ADJUSTABLE FITTINGS



## VB ADJUSTABLE ELBOW

Without straight screw- in screw-joint.

These parts are ready mounted not pre-assembled.

After screwing on by hand, tighten with a spanner until tight, and then apply final 30° turn.

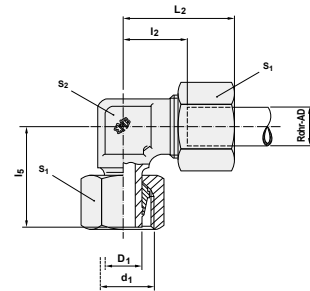

description	pipe OD	PN series	L <sub>2</sub>	l <sub>2</sub>	l <sub>5</sub>	D <sub>1</sub>	d <sub>1</sub>	S <sub>1</sub>	S <sub>2</sub>	kg / 100 pcs
DS-VB 6-L	6	L 500 (2200)	27	12.0	26.0	6	M 12x1.5	14	12	3.6
DS-VB 8-L	8		29	14.0	27.5	8	M 14x1.5	17	12	5.0
DS-VB 10-L	10		30	15.0	29.0	10	M 16x1.5	19	14	6.8
DS-VB 12-L	12	L 400 (1700)	32	17.0	29.5	12	M 18x1.5	22	17	9.0
DS-VB 15-L	15		36	21.0	32.5	15	M 22x1.5	27	19	15.3
DS-VB 18-L	18		40	23.5	35.5	18	M 26x1.5	32	24	22.6
DS-VB 22-L	22	L 250 (1100)	44	27.5	38.5	22	M 30x2	36	27	30.4
DS-VB 28-L	28		47	30.5	41.5	28	M 36x2	41	36	42.5
DS-VB 35-L	35		56	34.5	51.0	35	M 45x2	50	41	64.7
DS-VB 42-L	42	S 800 (3400)	63	40.0	56.0	42	M 52x2	60	50	99.7
DS-VB 6-S	6		31	16.0	27.0	6	M 14x1.5	17	12	5.7
DS-VB 8-S	8		32	17.0	27.5	8	M 16x1.5	19	14	7.0
DS-VB 10-S	10	S 630 (2700)	34	17.5	30.0	10	M 18x1.5	22	17	11.1
DS-VB 12-S	12		38	21.5	31.0	12	M 20x1.5	24	17	13.8
DS-VB 14-S	14		40	22.0	35.0	14	M 22x1.5	27	19	18.9
DS-VB 16-S	16	S 400 (1700)	43	24.5	36.5	16	M 24x1.5	30	24	23.8
DS-VB 20-S	20		48	26.5	44.5	20	M 30x2	36	27	36.2
DS-VB 25-S	25		54	30.0	50.0	25	M 36x2	46	36	72.1
DS-VB 30-S	30	S 400 (1700)	62	35.5	55.0	30	M 42x2	50	41	96.4
DS-VB 38-S	38		72	41.0	63.0	38	M 52x2	60	50	138.4

L<sub>2</sub> = approximate length with nut tightened

Please see "Engineering and technical data - Selecting the correct tube fitting" for more information on pressure.

# TUBE FITTINGS

ADJUSTABLE FITTINGS



## VC ADJUSTABLE BRANCH TEE

Without straight screw- in screw-joint.

These parts are ready mounted  
not pre-assembled.

After screwing on by hand, tighten with  
a spanner until tight, and then apply  
final 30° turn.

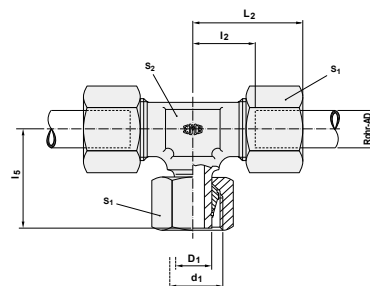

description	pipe OD	PN series	L <sub>2</sub>	l <sub>2</sub>	l <sub>5</sub>	D <sub>1</sub>	d <sub>1</sub>	S <sub>1</sub>	S <sub>2</sub>	kg / 100 pcs
DS-VC 6-L	6	L 500 (2200)	27	12.0	26.0	6	M 12x1.5	14	12	5.3
DS-VC 8-L	8		29	14.0	27.5	8	M 14x1.5	17	12	7.4
DS-VC 10-L	10		30	15.0	29.0	10	M 16x1.5	19	14	10.3
DS-VC 12-L	12	L 400 (1700)	32	17.0	29.5	12	M 18x1.5	22	17	12.9
DS-VC 15-L	15		36	21.0	32.5	15	M 22x1.5	27	19	21.8
DS-VC 18-L	18		40	23.5	35.5	18	M 26x1.5	32	24	32.4
DS-VC 22-L	22	L 250 (1100)	44	27.5	38.5	22	M 30x2	36	27	43.3
DS-VC 28-L	28		47	30.5	41.5	28	M 36x2	41	36	57.9
DS-VC 35-L	35		56	34.5	51.0	35	M 45x2	50	41	90.1
DS-VC 42-L	42	S 800 (3400)	63	40.0	56.0	42	M 52x2	60	50	135.3
DS-VC 6-S	6		31	16.0	27.0	6	M 14x1.5	17	12	8.5
DS-VC 8-S	8		32	17.0	27.5	8	M 16x1.5	19	14	10.7
DS-VC 10-S	10	S 630 (2700)	34	17.5	30.0	10	M 18x1.5	22	17	16.5
DS-VC 12-S	12		38	21.5	31.0	12	M 20x1.5	24	17	20.4
DS-VC 14-S	14		40	22.0	35.0	14	M 22x1.5	27	19	27.5
DS-VC 16-S	16	S 400 (1700)	43	24.5	36.5	16	M 24x1.5	30	24	35.6
DS-VC 20-S	20		48	26.5	44.5	20	M 30x2	36	27	53.6
DS-VC 25-S	25		54	30.0	50.0	25	M 36x2	46	36	104.2
DS-VC 30-S	30	S 400 (1700)	62	35.5	55.0	30	M 42x2	50	41	133.3
DS-VC 38-S	38		72	41.0	63.0	38	M 52x2	60	50	204.7

L<sub>2</sub> = approximate length with nut tightened

Please see "Engineering and technical data - Selecting the correct tube fitting" for more information on pressure.



# TUBE FITTINGS

ADJUSTABLE FITTINGS

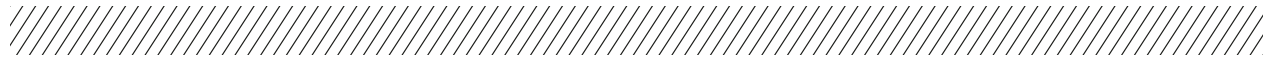

## VD ADJUSTABLE BARREL TEE

Without straight screw- in screw-joint.

These parts are ready mounted  
not pre-assembled.

After screwing on by hand, tighten with  
a spanner until tight, and then apply final 30° turn.

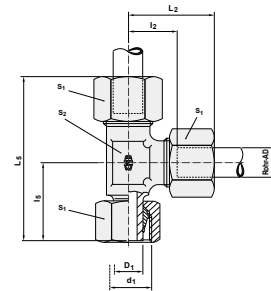

description	pipe OD	PN series	L <sub>2</sub>	L <sub>1</sub>	L <sub>5</sub>	L <sub>5</sub>	D <sub>1</sub>	d <sub>1</sub>	S <sub>1</sub>	S <sub>2</sub>	kg / 100 pcs
DS-VD 6-L	6	L 500 (2200)	27	12.0	26.0	53	6	M 12x1.5	14	12	5.2
DS-VD 8-L	8		29	14.0	27.5	56	8	M 14x1.5	17	12	7.8
DS-VD 10-L	10		30	15.0	29.0	59	10	M 16x1.5	19	14	10.5
DS-VD 12-L	12	L 400 (1700)	32	17.0	29.5	62	12	M 18x1.5	22	17	12.6
DS-VD 15-L	15		36	21.0	32.5	70	15	M 22x1.5	27	19	21.8
DS-VD 18-L	18		40	23.5	35.5	76	18	M 26x1.5	32	24	32.9
DS-VD 22-L	22	L 250 (1100)	44	27.5	38.5	83	22	M 30x2	36	27	43.3
DS-VD 28-L	28		47	30.5	41.5	91	28	M 36x2	41	36	55.8
DS-VD 35-L	35		56	34.5	51.0	111	35	M 45x2	50	41	89.1
DS-VD 42-L	42	S 800 (3400)	63	40.0	56.0	123	42	M 52x2	60	50	132.8
DS-VD 6-S	6		31	16.0	27.0	58	6	M 14x1.5	17	12	8.7
DS-VD 8-S	8		32	17.0	27.5	61	8	M 16x1.5	19	14	10.7
DS-VD 10-S	10	S 630 (2700)	34	17.5	30.0	66	10	M 18x1.5	22	17	16.6
DS-VD 12-S	12		38	21.5	31.0	71	12	M 20x1.5	24	17	20.4
DS-VD 14-S	14		40	22.0	35.0	76	14	M 22x1.5	27	19	27.1
DS-VD 16-S	16	S 400 (1700)	43	24.5	36.5	80	16	M 24x1.5	30	24	33.7
DS-VD 20-S	20		48	26.5	44.5	93	20	M 30x2	36	27	54.2
DS-VD 25-S	25		54	30.0	50.0	105	25	M 36x2	46	36	102.6
DS-VD 30-S	30	S 400 (1700)	62	35.5	55.0	119	30	M 42x2	50	41	132.5
DS-VD 38-S	38		72	41.0	63.0	139	38	M 52x2	60	50	195.0

L<sub>2</sub> = approximate length with nut tightened

Please see "Engineering and technical data - Selecting the correct tube fitting" for more information on pressure.

# TUBE FITTINGS

ADJUSTABLE FITTINGS

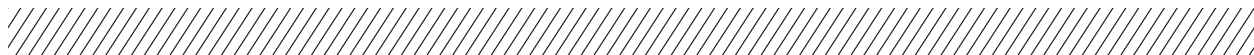

## VBDKO ADJUSTABLE MALE STUD ELBOW

With taper and O-ring according to DIN 3865.

O-ring NBR (e.g. Perbunan), FKM (e.g. Viton) upon request.

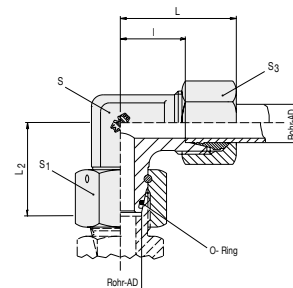

description	pipe OD	PN series	L <sub>2</sub>	L	l	S	S <sub>1</sub>	S <sub>3</sub>	kg / 100 pcs	O-Ring
DS-VBDKO 6-L	6	L 500 (2200)	26.0	27	12.0	12	17	14	4.0	4x1.5
DS-VBDKO 8-L	8		27.5	29	14.0	12	17	17	5.5	6x1.5
DS-VBDKO 10-L	10		29.0	30	15.0	14	19	19	7.1	7.5x1.5
DS-VBDKO 12-L	12	L 400 (1700)	29.5	32	17.0	17	22	22	9.6	9x1.5
DS-VBDKO 15-L	15		32.5	36	21.0	19	27	27	16.6	12x2
DS-VBDKO 18-L	18		35.5	40	23.5	24	32	32	23.6	15x2
DS-VBDKO 22-L	22	L 250 (1100)	38.5	44	27.5	27	36	36	32.7	20x2
DS-VBDKO 28-L	28		41.5	47	30.5	36	41	41	52.4	26x2
DS-VBDKO 35-L	35		51.0	56	34.5	41	50	50	68.8	32x2.5
DS-VBDKO 42-L	42	S 800 (3400)	56.0	63	40.0	50	60	60	108.0	38x2.5
DS-VBDKO 6-S	6		27.0	31	16.0	14	17	17	6.2	4x1.5
DS-VBDKO 8-S	8		27.5	32	17.0	17	19	19	7.4	6x1.5
DS-VBDKO 10-S	10	S 630 (2700)	30.0	34	17.5	19	22	22	11.3	7.5x1.5
DS-VBDKO 12-S	12		31.0	38	21.5	22	24	24	14.0	9x1.5
DS-VBDKO 14-S	14		35.0	40	22.0	19	27	27	19.3	10x2
DS-VBDKO 16-S	16	S 400 (1700)	36.5	43	24.5	24	30	30	25.8	12x2
DS-VBDKO 20-S	20		44.5	48	26.5	27	36	36	40.3	16.3x2.4
DS-VBDKO 25-S	25		50.0	54	30.0	36	46	46	75.1	20.3x2.4
DS-VBDKO 30-S	30	S 400 (1700)	55.0	62	35.5	41	50	50	96.4	25.3x2.4
DS-VBDKO 38-S	38		63.0	72	41.0	50	60	60	142.5	33.3x2.4

L = approximate length with nut tightened

Please see "Engineering and technical data - Selecting the correct tube fitting" for more information on pressure.

# TUBE FITTINGS

ADJUSTABLE FITTINGS

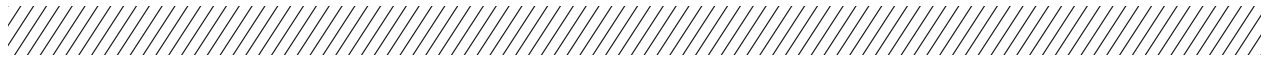

## BFDKO ADJUSTABLE 45° ELBOW

O-ring NBR (e.g. Perbunan), FKM (e.g. Viton) upon request.

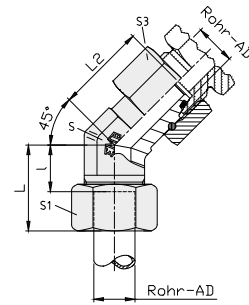

description	pipe OD	PN series	L <sub>2</sub>	L	I	S	S <sub>1</sub>	S <sub>3</sub>	kg / 100 pcs	O-Ring
DS-BFDKO 6-L	6	L 500	26.0	24	9	14	17	14	4.3	4.5x1.5
DS-BFDKO 8-L	8		27.5	27	12	14	17	17	5.7	6.5x1.5
DS-BFDKO 10-L	10		29.0	27	12	19	19	19	7.3	8x1.5
DS-BFDKO 12-L	12	L 400	29.5	28	14	19	22	22	10.0	10x1.5
DS-BFDKO 15-L	15		32.5	32	17	22	27	27	16.8	12x2
DS-BFDKO 18-L	18		35.5	33	17	27	32	32	24.1	15x2
DS-BFDKO 22-L	22	L 250	38.5	35	19	30	36	36	33.0	20x2
DS-BFDKO 28-L	28		41.5	40	23	36	41	41	49.3	26x2
DS-BFDKO 35-L	35		51.0	48	27	50	50	50	69.0	32x2.5
DS-BFDKO 42-L	42	S 800	56.0	49	26	50	60	60	108.1	38x2.5
DS-BFDKO 6-S	6		27.0	24	9	14	17	17	6.4	4.5x1.5
DS-BFDKO 8-S	8		27.5	27	12	19	19	19	8.4	6.5x1.5
DS-BFDKO 10-S	10	S 630	30.0	29	13	19	22	22	11.5	8x1.5
DS-BFDKO 12-S	12		31.0	33	17	19	24	24	14.2	10x1.5
DS-BFDKO 16-S	16		36.5	34	16	19	30	30	26.0	13x2
DS-BFDKO 20-S	20	S 400	44.5	38	16	27	36	36	40.6	16.3x2.4
DS-BFDKO 25-S	25		50.0	43	19	36	46	46	74.7	20.3x2.4
DS-BFDKO 30-S	30		55.0	50	24	50	50	50	95.7	25.3x2.4
DS-BFDKO 38-S	38		63.0	52	21	50	60	60	142.9	33.3x2.4

Please see "Engineering and technical data - Selecting the correct tube fitting" for more information on pressure.

# TUBE FITTINGS

ADJUSTABLE FITTINGS



## VCDKO ADJUSTABLE EQUAL TEE

With taper and O-ring according to DIN 3865.

O-ring NBR (e.g. Perbunan), FKM (e.g. Viton) upon request.

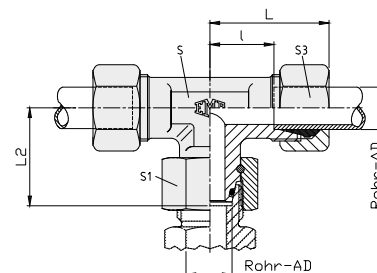

description	pipe OD	PN series	L <sub>2</sub>	L	l	S (A) profile	S (B) forging	S <sub>1</sub>	S <sub>3</sub>	kg / 100 pcs	O-Ring
DS-VCDKO 6-L	6	L 500 (2200)	26.0	27	12.0	12	12	17	14	5.8	4x1.5
DS-VCDKO 8-L	8		27.5	29	14.0	14	12	17	17	7.9	6x1.5
DS-VCDKO 10-L	10		29.0	30	15.0	17	14	19	19	10.1	7.5x1.5
DS-VCDKO 12-L	12	L 400 (1700)	29.5	32	17.0	19	17	22	22	13.5	9x1.5
DS-VCDKO 15-L	15		32.5	36	21.0		19	27	27	23.3	12x2
DS-VCDKO 18-L	18		35.5	40	23.5		24	32	32	33.2	15x2
DS-VCDKO 22-L	22	L 250 (1100)	38.5	44	27.5		27	36	36	44.6	20x2
DS-VCDKO 28-L	28		41.5	47	30.5		36	41	41	70.2	26x2
DS-VCDKO 35-L	35		51.0	56	34.5		41	50	50	96.1	32x2.5
DS-VCDKO 42-L	42	S 800 (3400)	56.0	63	40.0		50	60	60	146.1	38x2.5
DS-VCDKO 6-S	6		27.0	31	16.0		14	17	17	8.7	4x1.5
DS-VCDKO 8-S	8		27.5	32	17.0		17	19	19	11.8	6x1.5
DS-VCDKO 10-S	10	S 630 (2700)	30.0	34	17.5		19	22	22	16.3	7.5x1.5
DS-VCDKO 12-S	12		31.0	38	21.5		22	24	24	20.6	9x1.5
DS-VCDKO 14-S	14		35.0	40	22.0		19	27	27	28.1	10x2
DS-VCDKO 16-S	16	S 400 (1700)	36.5	43	24.5		24	30	30	37.3	12x2
DS-VCDKO 20-S	20		44.5	48	26.5		27	36	36	56.8	16.3x2.4
DS-VCDKO 25-S	25		50.0	54	30.0		36	46	46	107.9	20.3x2.4
DS-VCDKO 30-S	30	S 400 (1700)	55.0	62	35.5		41	50	50	136.3	25.3x2.4
DS-VCDKO 38-S	38		63.0	72	41.0		50	60	60	203.6	33.3x2.4

L = approximate length with nut tightened

Pipe OD 6-42 = forging

Please see "Engineering and technical data - Selecting the correct tube fitting" for more information on pressure.

# TUBE FITTINGS

ADJUSTABLE FITTINGS



## VDDKO ADJUSTABLE MALE STUD TEE-STUD BARREL

With taper and O-ring according to DIN 3865.

O-ring NBR (e.g. Perbunan),  
FKM (e.g. Viton) upon request.

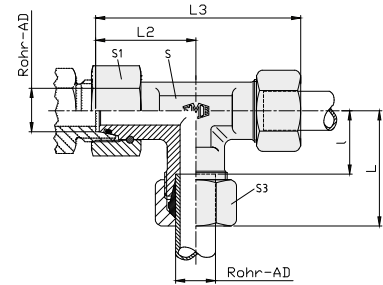

description	pipe OD	PN series	L <sub>2</sub>	L	l	S (A) profile	S (B) forging	S <sub>1</sub>	S <sub>3</sub>	L <sub>3</sub>	kg / 100 pcs	O-Ring
DS-VDDKO 6-L	6	L 500 (2200)	26.0	27	12.0	12	12	17	14	53	5.8	4x1.5
DS-VDDKO 8-L	8		27.5	29	14.0	14	12	17	17	56	7.9	6x1.5
DS-VDDKO 10-L	10		29.0	30	15.0	17	14	19	19	59	10.0	7.5x1.5
DS-VDDKO 12-L	12	L 400 (1700)	29.5	32	17.0	19	17	22	22	62	13.4	9x1.5
DS-VDDKO 15-L	15		32.5	36	21.0		19	27	27	70	23.3	12x2
DS-VDDKO 18-L	18		35.5	40	23.5		24	32	32	76	33.2	15x2
DS-VDDKO 22-L	22	L 250 (1100)	38.5	44	27.5		27	36	36	83	44.3	20x2
DS-VDDKO 28-L	28		41.5	47	30.5		36	41	41	91	70.2	26x2
DS-VDDKO 35-L	35		51.0	56	34.5		41	50	50	111	94.5	32x2.5
DS-VDDKO 42-L	42		56.0	63	40.0		50	60	60	123	146.3	38x2.5
DS-VDDKO 6-S	6	S 800 (3400)	27.0	31	16.0		14	17	17	58	9.1	4x1.5
DS-VDDKO 8-S	8		27.5	32	17.0		17	19	19	61	11.8	6x1.5
DS-VDDKO 10-S	10		30.0	34	17.5		19	22	22	66	16.4	7.5x1.5
DS-VDDKO 12-S	12	S 630 (2700)	31.0	38	21.5		22	24	24	71	20.7	9x1.5
DS-VDDKO 14-S	14		35.0	40	22.0		19	27	27	76	28.1	10x2
DS-VDDKO 16-S	16		36.5	43	24.5		24	30	30	80	38.2	12x2
DS-VDDKO 20-S	20	S 400 (1700)	44.5	48	26.5		27	36	36	93	58.3	16.3x2.4
DS-VDDKO 25-S	25		50.0	54	30.0		36	46	46	105	107.8	20.3x2.4
DS-VDDKO 30-S	30		55.0	62	35.5		41	50	50	119	138.0	25.3x2.4
DS-VDDKO 38-S	38		63.0	72	41.0		50	60	60	139	205.1	33.3x2.4

$L+L_3$  = approximate length with nut tightened

Pipe OD 6-42 = forging

Please see "Engineering and technical data - Selecting the correct tube fitting" for more information on pressure

# TUBE FITTINGS

STANDPIPE FITTINGS | VA STUD STANDPIPE FITTING



## VA STUD STANDPIPE FITTING BSP

These parts are ready mounted not pre-assembled.

After screwing on by hand, tighten with a spanner until tight, and then apply final 30° turn.

BSP parallel with stud.

Final assembled according to DIN 3955.

Captive seal NBR (e.g. Perbunan), FKM (e.g. Viton) upon request.

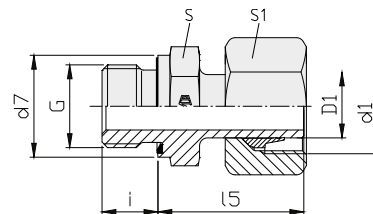

description	pipe OD	PN series	$l_5$	$d_7$	$D_1$	$i$	$S_1$	$S$	$d_1$	$G$	kg / 100 pcs
DS-VA 6-RL/WD	6	L 500 (2200)	24.5	14	6	8	14	14	M 12x1.5	G 1/8" A	2.5
DS-VA 8-RL/WD	8		29.5	19	8	12	17	19	M 14x1.5	G 1/4" A	4.5
DS-VA 10-RL/WD	10		27.5	19	10	12	19	19	M 16x1.5	G 1/4" A	4.7
DS-VA 12-RL/WD	12	L 400 (1700)	34.0	22	12	12	22	22	M 18x1.5	G 3/8" A	6.3
DS-VA 15-RL/WD	15		32.0	27	15	14	27	27	M 22x1.5	G 1/2" A	11.5
DS-VA 18-RL/WD	18		31.5	27	18	14	32	27	M 26x1.5	G 1/2" A	12.9
DS-VA 22-RL/WD	22	L 250 (1100)	32.5	32	22	16	36	32	M 30x2	G 3/4" A	17.6
DS-VA 28-RL/WD	28		35.0	40	28	18	41	41	M 36x2	G 1" A	24.7
DS-VA 35-RL/WD	35		42.5	50	35	20	50	50	M 45x2	G 1 1/4" A	40.7
DS-VA 42-RL/WD	42	S 800 (3400)	46.5	55	42	22	60	55	M 52x2	G 1 1/2" A	45.6
DS-VA 6-RS/WD	6		27.0	19	6	12	17	19	M 14x1.5	G 1/4" A	5.0
DS-VA 8-RS/WD	8		29.5	19	8	12	19	19	M 16x1.5	G 1/4" A	5.5
DS-VA 10-RS/WD	10	S 630 (2700)	32.0	22	10	12	22	22	M 18x1.5	G 3/8" A	8.2
DS-VA 12-RS/WD	12		34.0	22	12	12	24	22	M 20x1.5	G 3/8" A	9.5
DS-VA 12-S/R 1/2"/WD	12		33.5	27	12	14	24	27	M 20x1.5	G 1/2" A	11.8
DS-VA 14-RS/WD	14	S 400 (1700)	36.5	27	14	14	27	27	M 22x1.5	G 1/2" A	14.8
DS-VA 16-RS/WD	16		37.0	27	16	14	30	27	M 24x1.5	G 1/2" A	15.4
DS-VA 16-S/R 3/4"/WD	16		39.0	32	16	16	30	32	M 24x1.5	G 3/4" A	20.0
DS-VA 20-RS/WD	20	S 400 (1700)	43.0	32	20	16	36	32	M 30x2	G 3/4" A	25.3
DS-VA 25-RS/WD	25		48.0	40	25	18	46	41	M 36x2	G 1" A	46.5
DS-VA 30-RS/WD	30		51.0	50	30	20	50	50	M 42x2	G 1 1/4" A	64.4
DS-VA 38-RS/WD	38		60.0	55	38	22	60	55	M 52x2	G 1 1/2" A	88.9

Please see "Engineering and technical data - Selecting the correct tube fitting" for more information on pressure.

# TUBE FITTINGS

STANDPIPE FITTINGS | VA STUD STANDPIPE FITTING

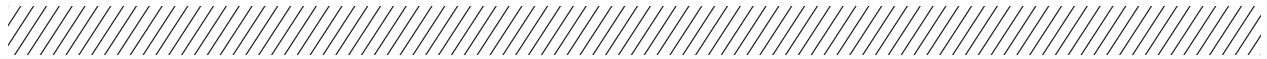

## VA STUD STANDPIPE FITTING METRIC

These parts are ready mounted not pre-assembled.

After screwing on by hand, tighten with a spanner until tight, and then apply final 30° turn.

Metric parallel with stud.

Final assembled according to DIN 3955.

Captive seal NBR (e.g. Perbunan), FKM (e.g. Viton) upon request.

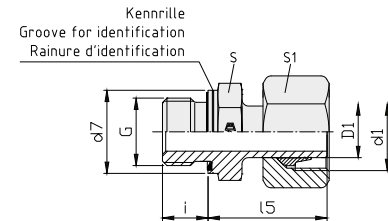

description	pipe OD	PN series	$l_5$	$d_7$	$D_1$	$i$	$S_1$	$S$	$d_1$	$G$	kg / 100 pcs
DS-VA 6-ML/WD	6	L 500 (2200)	24.5	14	6	8	14	14	M 12x1.5	M 10x1	2.5
DS-VA 8-ML/WD	8		26.5	17	8	12	17	17	M 14x1.5	M 12x1.5	4.0
DS-VA 10-ML/WD	10		27.5	19	10	12	19	19	M 16x1.5	M 14x1.5	4.7
DS-VA 12-ML/WD	12	L 400 (1700)	30.5	22	12	12	22	22	M 18x1.5	M 16x1.5	6.3
DS-VA 15-ML/WD	15		31.5	24	15	12	27	24	M 22x1.5	M 18x1.5	9.5
DS-VA 18-ML/WD	18		31.5	27	18	14	32	27	M 26x1.5	M 22x1.5	12.9
DS-VA 22-ML/WD	22	L 250 (1100)	32.5	32	22	16	36	32	M 30x2	M 26x1.5	17.6
DS-VA 28-ML/WD	28		35.0	40	28	18	41	41	M 36x2	M 33x2	24.7
DS-VA 35-ML/WD	35		42.5	50	35	20	50	50	M 45x2	M 42x2	40.7
DS-VA 42-ML/WD	42		46.5	55	42	22	60	55	M 52x2	M 48x2	45.6
DS-VA 6-MS/WD	6	S 800 (3400)	27.0	17	6	12	17	17	M 14x1.5	M 12x1.5	4.5
DS-VA 8-MS/WD	8		29.5	19	8	12	19	19	M 16x1.5	M 14x1.5	5.5
DS-VA 10-MS/WD	10		32.0	22	10	12	22	22	M 18x1.5	M 16x1.5	8.2
DS-VA 12-MS/WD	12	S 630 (2700)	34.0	24	12	12	24	24	M 20x1.5	M 18x1.5	10.5
DS-VA 14-MS/WD	14		36.5	26	14	14	27	27	M 22x1.5	M 20x1.5	14.8
DS-VA 16-MS/WD	16		37.0	27	16	14	30	27	M 24x1.5	M 22x1.5	15.4
DS-VA 20-MS/WD	20	S 400 (1700)	43.0	32	20	16	36	32	M 30x2	M 27x2	25.3
DS-VA 25-MS/WD	25		48.0	40	25	18	46	41	M 36x2	M 33x2	46.5
DS-VA 30-MS/WD	30		51.0	50	30	20	50	50	M 42x2	M 42x2	64.4
DS-VA 38-MS/WD	38		60.0	55	38	22	60	55	M 52x2	M 48x2	88.9

Please see "Engineering and technical data - Selecting the correct tube fitting" for more information on pressure.

# TUBE FITTINGS

STANDPIPE FITTINGS | VA STUD STANDPIPE FITTING



## VA STUD STANDPIPE FITTING NPT

These parts are ready mounted not pre-assembled.

After screwing on by hand, tighten with a spanner until tight, and then apply final 30° turn.

NPT (ANSI, ASME B1-20.1.1983).

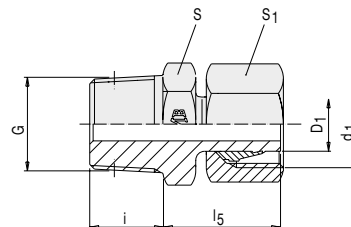

description	pipe OD	PN series	$l_5$	$D_1$	$i$	$S_1$	$S$	$d_1$	$G$	kg / 100 pcs	
DS-VA 6-L/NPT	6	L 315 (1260)	24.0	6	10.0	14	11	M 12x1.5	1/8" NPT	2.6	
DS-VA 8-L/NPT	8		27.5	8	15.0	17	14	M 14x1.5	1/4" NPT	4.1	
DS-VA 10-L/NPT	10		25.5	10	15.0	19	14	M 16x1.5	1/4" NPT	4.8	
DS-VA 12-L/NPT	12		31.5	12	15.0	22	19	M 18x1.5	3/8" NPT	6.5	
DS-VA 15-L/NPT	15		29.0	15	20.0	27	22	M 22x1.5	1/2" NPT	11.0	
DS-VA 18-L/NPT	18		28.5	18	20.0	32	22	M 26x1.5	1/2" NPT	13.5	
DS-VA 22-L/NPT	22	L 160 (640)	29.5	22	20.0	36	27	M 30x2	3/4" NPT	19.0	
DS-VA 28-L/NPT	28		32.0	28	25.0	41	36	M 36x2	1" NPT	27.4	
DS-VA 35-L/NPT	35		39.5	35	25.5	50	46	M 45x2	1 1/4" NPT	40.5	
DS-VA 42-L/NPT	42		43.5	42	26.0	60	50	M 52x2	1 1/2" NPT	57.5	
DS-VA 6-S/NPT	6		S 630 (2520)	25.0	6	15.0	17	14	M 14x1.5	1/4" NPT	5.0
DS-VA 8-S/NPT	8			27.5	8	15.0	19	14	M 16x1.5	1/4" NPT	5.5
DS-VA 10-S/NPT	10	29.5		10	15.0	22	19	M 18x1.5	3/8" NPT	8.0	
DS-VA 12-S/NPT	12	31.5		12	15.0	24	19	M 20x1.5	3/8" NPT	10.0	
DS-VA 14-S/NPT	14	33.5		14	20.0	27	22	M 22x1.5	1/2" NPT	14.9	
DS-VA 16-S/NPT	16	34.0		16	20.0	30	22	M 24x1.5	1/2" NPT	16.4	
DS-VA 20-S/NPT	20	S 400 (1600)	40.0	20	20.0	36	27	M 30x2	3/4" NPT	25.0	
DS-VA 25-S/NPT	25		45.0	25	25.0	46	36	M 36x2	1" NPT	47.0	
DS-VA 30-S/NPT	30		48.0	30	25.5	50	46	M 42x2	1 1/4" NPT	61.9	
DS-VA 38-S/NPT	38		56.5	38	26.0	60	50	M 52x2	1 1/2" NPT	88.9	

Please see "Engineering and technical data - Selecting the correct tube fitting" for more information on pressure.



# TUBE FITTINGS

STANDPIPE FITTINGS | VADKO STUD STANDPIPE ADAPTOR



## VADKO STUD STANDPIPE ADAPTOR BSP

BSP parallel.

With taper and O-ring according to DIN 3865.

Captive seal NBR (e.g. Perbunan),  
FKM (e.g. Viton) upon request.

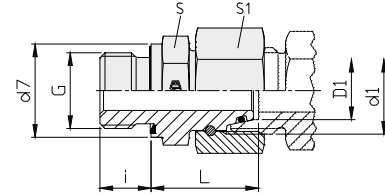

description	pipe OD	PN series	L	i	d <sub>7</sub>	G	D <sub>1</sub>	d <sub>1</sub>	S	S <sub>1</sub>	kg / 100 pcs	O-Ring
VADKO 6-RL/WD	6	L 500 (2200)	24.5	8	14	G 1/8" A	6	M 12x1.5	14	17	2.4	4x1.5
VADKO 8-RL/WD	8		29.5	12	19	G 1/4" A	8	M 14x1.5	19	17	4.4	6x1.5
VADKO 10-RL/WD	10		27.5	12	19	G 1/4" A	10	M 16x1.5	19	19	4.7	7.5x1.5
VADKO 12-RL/R1/4"/WD	12	L 400 (1700)	27.5	12	19	G 1/4" A	12	M 18x1.5	19	22	6.8	9x1.5
VADKO 12-RL/WD	12		34.0	12	22	G 3/8" A	12	M 18x1.5	22	22	6.9	9x1.5
VADKO 15-RL/WD	15		32.0	14	27	G 1/2" A	15	M 22x1.5	27	27	12.1	12x2
VADKO 18-RL/WD	18		31.5	14	27	G 1/2" A	18	M 26x1.5	27	32	13.4	15x2
VADKO 22-RL/WD	22	L 250 (1100)	32.5	16	32	G 3/4" A	22	M 30x2	32	36	19.6	20x2
VADKO 28-RL/WD	28		35.0	18	40	G 1" A	28	M 36x2	41	41	36.0	26x2
VADKO 35-RL/WD	35		42.5	20	50	G 1 1/4" A	35	M 45x2	50	50	45.5	32x2.5
VADKO 42-RL/WD	42		46.5	22	55	G 1 1/2" A	42	M 52x2	55	60	66.2	38x2.5
VADKO 6-RS/WD	6	S 800 (3400)	27.0	12	19	G 1/4" A	6	M 14x1.5	19	17	4.5	4x1.5
VADKO 8-RS/WD	8		29.5	12	19	G 1/4" A	8	M 16x1.5	19	19	5.0	6x1.5
VADKO 10-RS/WD	10		32.0	12	22	G 3/8" A	10	M 18x1.5	22	22	7.4	7.5x1.5
VADKO 12-RS/WD	12	S 630 (2700)	34.0	12	22	G 3/8" A	12	M 20x1.5	22	24	8.2	9x1.5
VADKO 12-S/R1/2"/WD	12		34.5	14	27	G 1/2" A	12	M 20x1.5	27	24	15.3	9x1.5
VADKO 14-RS/WD	14		36.5	14	27	G 1/2" A	14	M 22x1.5	27	27	12.6	10x2
VADKO 16-RS/WD	16		37.0	14	27	G 1/2" A	16	M 24x1.5	27	30	14.6	12x2
VADKO 20-RS/WD	20	S 400 (1700)	43.0	16	32	G 3/4" A	20	M 30x2	32	36	22.1	16.3x2.4
VADKO 25-RS/WD	25		48.0	18	40	G 1" A	25	M 36x2	41	46	40.2	20.3x2.4
VADKO 30-RS/WD	30		51.0	20	50	G 1 1/4" A	30	M 42x2	50	50	58.2	25.3x2.4
VADKO 38-RS/WD	38		60.0	22	55	G 1 1/2" A	38	M 52x2	55	60	78.6	33.3x2.4

Please see "Engineering and technical data - Selecting the correct tube fitting" for more information on pressure.

# TUBE FITTINGS

STANDPIPE FITTINGS | VADKO STUD STANDPIPE ADAPTOR

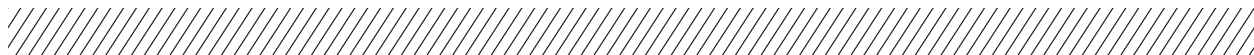

## VADKO STUD STANDPIPE ADAPTOR METRIC

Metric parallel.

With taper and O-ring according to DIN 3865.

Captive seal NBR (e.g. Perbunan), FKM (e.g. Viton) upon request.

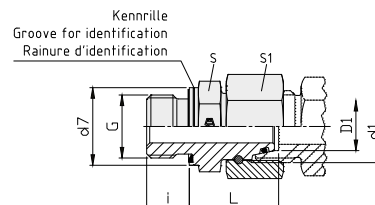

description	pipe OD	PN series	L	i	d <sub>7</sub>	G	D <sub>1</sub>	d <sub>1</sub>	S	S <sub>1</sub>	kg / 100 pcs	O-Ring
VADKO 6-ML/WD	6	L 500 (2200)	24.5	8	14	M 10x1	6	M 12x1.5	14	17	2.3	4 x1.5
VADKO 8-ML/WD	8		26.5	12	17	M 12x1.5	8	M 14x1.5	17	17	3.8	6 x1.5
VADKO 10-ML/WD	10		27.5	12	19	M 14x1.5	10	M 16x1.5	19	19	4.8	7.5x1.5
VADKO 12-ML/WD	12	L 400 (1700)	30.5	12	22	M 16x1.5	12	M 18x1.5	22	22	6.7	9 x1.5
VADKO 15-ML/WD	15		31.5	12	24	M 18x1.5	15	M 22x1.5	24	27	10.1	12x2
VADKO 18-ML/WD	18		31.5	14	27	M 22x1.5	18	M 26x1.5	27	32	13.8	15x2
VADKO 22-ML/WD	22	L 250 (1100)	32.5	16	32	M 26x1.5	22	M 30x2	32	36	19.9	20x2
VADKO 28-ML/WD	28		35.0	18	40	M 33x2	28	M 36x2	41	41	35.8	26x2
VADKO 35-ML/WD	35		42.5	20	50	M 42x2	35	M 45x2	50	50	45.0	32x2.5
VADKO 42-ML/WD	42	S 800 (3400)	46.5	22	55	M 48x2	42	M 52x2	55	60	70.8	38x2.5
VADKO 6-MS/WD	6		27.0	12	17	M 12x1.5	6	M 14x1.5	17	17	4.0	4x1.5
VADKO 8-MS/WD	8		29.5	12	19	M 14x1.5	8	M 16x1.5	19	19	5.1	6x1.5
VADKO 10-MS/WD	10	S 630 (2700)	32.0	12	22	M 16x1.5	10	M 18x1.5	22	22	7.1	7.5x1.5
VADKO 12-MS/WD	12		34.0	12	24	M 18x1.5	12	M 20x1.5	24	24	8.9	9x1.5
VADKO 14-MS/WD	14		36.5	14	26	M 20x1.5	14	M 22x1.5	27	27	12.1	10x2
VADKO 16-MS/WD	16	S 400 (1700)	37.0	14	27	M 22x1.5	16	M 24x1.5	27	30	14.8	12x2
VADKO 20-MS/WD	20		43.0	16	32	M 27x2	20	M 30x2	32	36	22.3	16.3x2.4
VADKO 25-MS/WD	25		48.0	18	40	M 33x2	25	M 36x2	41	46	40.0	20.3x2.4
VADKO 30-MS/WD	30	S 400 (1700)	51.0	20	50	M 42x2	30	M 42x2	50	50	58.3	25.3x2.4
VADKO 38-MS/WD	38		60.0	22	55	M 48x2	38	M 52x2	55	60	78.2	33.3x2.4

Please see "Engineering and technical data - Selecting the correct tube fitting" for more information on pressure.

# TUBE FITTINGS

STANDPIPE FITTINGS | VADKO STUD STANDPIPE ADAPTOR



## VADKO STUD STANDPIPE ADAPTOR NPT

NPT (ANSI, ASME B1-20.1.1983).

With taper and O-ring according to DIN 3865.

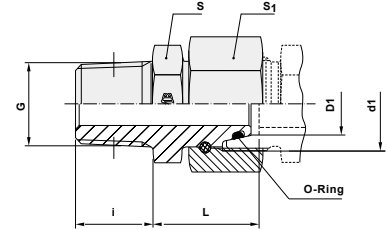

description	pipe OD	PN series	L	i	G	D <sub>1</sub>	d <sub>1</sub>	S	S <sub>1</sub>	kg / 100 pcs	O-Ring
VADKO 6-L/NPT	6	L 315 (1260)	20.5	10.0	1/8"NPT	6	M 12x1.5	11	17	2.3	4x1.5
VADKO 8-L/NPT	8		22.5	15.0	1/4"NPT	8	M 14x1.5	14	17	4.1	6x1.5
VADKO 10-L/NPT	10		23.0	15.0	1/4"NPT	10	M 16x1.5	14	19	4.4	7.5x1.5
VADKO 12-L/NPT	12		24.7	15.3	3/8"NPT	12	M 18x1.5	19	22	6.9	9x1.5
VADKO 15-L/NPT	15		29.5	20.0	1/2"NPT	15	M 22x1.5	22	27	12.7	2x2
VADKO 18-L/NPT	18		29.0	20.0	1/2"NPT	18	M 26x1.5	24	32	14.2	15x2
VADKO 22-L/NPT	22	L 160 (640)	32.0	20.0	3/4"NPT	22	M 30x2	27	36	20.0	20x2
VADKO 28-L/NPT	28		36.0	25.0	1" NPT	28	M 36x2	36	41	30.6	26x2
VADKO 35-L/NPT	35		40.0	25.5	1/4"NPT	35	M 45x2	46	50	48.6	32x2.5
VADKO 42-L/NPT	42		42.5	26.0	1 1/2"NPT	42	M 52x2	50	60	66.2	38x2.5
VADKO 6-S/NPT	6	S 630 (2520)	22.5	15.0	1/4"NPT	6	M 14x1.5	14	17	4.2	4x1.5
VADKO 8-S/NPT	8		23.0	15.0	1/4"NPT	8	M 16x1.5	14	19	4.7	6x1.5
VADKO 10-S/NPT	10		25.2	15.3	3/8"NPT	10	M 18x1.5	19	22	7.5	7.5x1.5
VADKO 12-S/NPT	12		26.7	15.3	3/8"NPT	12	M 20x1.5	19	24	8.1	9x1.5
VADKO 14-S/NPT	14		30.5	20.0	1/2"NPT	14	M 22x1.5	22	27	13.1	10x2
VADKO 16-S/NPT	16		31.0	20.0	1/2"NPT	16	M 24x1.5	22	30	14.5	12x2
VADKO 20-S/NPT	20	S 400 (1600)	34.0	20.0	3/4"NPT	20	M 30x2	27	36	22.1	16.3x2.4
VADKO 25-S/NPT	25		38.5	25.0	1"NPT	25	M 36x2	36	46	42.2	20.3x2.4
VADKO 30-S/NPT	30		45.0	25.5	1 1/4"NPT	30	M 42x2	46	50	62.8	25.3x2.4
VADKO 38-S/NPT	38		47.5	26.0	1 1/2"NPT	38	M 52x2	50	60	77.0	33.3x2.4

Please see "Engineering and technical data - Selecting the correct tube fitting" for more information on pressure.

# TUBE FITTINGS

STRAIGHT FITTINGS AND REDUCERS



## EDKO STRAIGHT FITTING TAPER

Taper on both ends and O-ring to DIN 3865.

O-ring NBR (e.g. Perbunan), according to  
FKM (e.g. Viton) upon request.

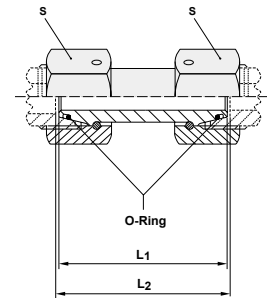

description	pipe OD	PN series	L <sub>1</sub>	L <sub>2</sub>	S	O-Ring
EDKO 6-L	6	L 500 (2200)	33.0	36.0	17	4x1.5
EDKO 8-L	8		33.0	36.0	17	6x1.5
EDKO 10-L	10		35.0	37.0	19	7.5x1.5
EDKO 12-L	12	L 400 (1700)	35.0	37.0	22	9x1.5
EDKO 15-L	15		38.0	40.0	27	12x2
EDKO 18-L	18		39.5	42.5	32	15x2
EDKO 22-L	22	L 250 (1100)	44.0	47.0	36	20x2
EDKO 28-L	28		46.0	49.0	41	26x2
EDKO 35-L	35		52.0	58.0	50	32x2.5
EDKO 42-L	42	S 800 (3400)	52.0	59.0	60	38x2.5
EDKO 6-S	6		36.0	39.0	17	4x1.5
EDKO 8-S	8		36.0	39.0	19	6x1.5
EDKO 10-S	10	S 630 (2700)	40.0	43.0	22	7.5x1.5
EDKO 12-S	12		41.0	44.0	24	9x1.5
EDKO 14-S	14		44.0	48.0	27	10x2
EDKO 16-S	16	S 400 (1700)	45.0	50.0	30	12x2
EDKO 20-S	20		54.0	60.0	36	16.3x2.4
EDKO 25-S	25		59.0	66.0	46	20.3x2.4
EDKO 30-S	30	S 400 (1700)	63.0	73.0	50	25.3x2.4
EDKO 38-S	38		68.0	83.0	60	33.3x2.4

Please see "Engineering and technical data - Selecting the correct tube fitting" for more information on pressure.

# TUBE FITTINGS

STRAIGHT FITTINGS AND REDUCERS



## EDKOR STRAIGHT REDUCER FITTING TAPER

Taper on both ends and O-ring to DIN 3865.

O-ring NBR (e.g. Perbunan), FKM (e.g. Viton) upon request.

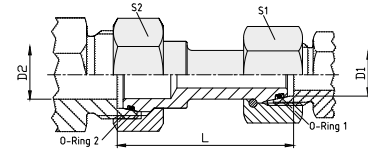

description	PB	pipe D <sub>1</sub>	pipe D <sub>2</sub>	L (± 2 mm)	S <sub>1</sub>	S <sub>2</sub>	O-Ring 1	O-Ring 2
EDKOR 6L/6S	500	6L	6S	35.0	14	17	4x1.5	4x1.5
EDKOR 6L/8L	500	6L	8L	34.0	14	17	4x1.5	6x1.5
EDKOR 6L/8S	500	6L	8S	37.0	14	19	4x1.5	6x1.5
EDKOR 6L/10L	500	6L	10L	34.0	14	19	4x1.5	7.5x1.5
EDKOR 6L/10S	500	6L	10S	35.0	14	22	4x1.5	7.5x1.5
EDKOR 8L/8S	500	8L	8S	37.0	17	19	6x1.5	6x1.5
EDKOR 8L/10L	500	8L	10L	34.0	17	19	6x1.5	7.5x1.5
EDKOR 8L/10S	500	8L	10S	35.0	17	22	6x1.5	7.5x1.5
EDKOR 8L/12L	500	8L	12L	34.0	17	22	6x1.5	9x1.5
EDKOR 8L/12S	500	8L	12S	35.0	17	24	6x1.5	9x1.5
EDKOR 10S/10L	500	10S	10L	37.0	22	19	7.5x1.5	7.5x1.5
EDKOR 10L/12L	500	10L	12L	36.0	19	22	7.5x1.5	9x1.5
EDKOR 10L/12S	500	10L	12S	37.0	19	24	7.5x1.5	9x1.5
EDKOR 10S/12L	400	10S	12L	36.0	22	22	7.5x1.5	9x1.5
EDKOR 10S/12S	630	10S	12S	37.0	22	24	7.5x1.5	9x1.5
EDKOR 10L/14S	500	10L	14S	39.0	19	27	7.5x1.5	10x2
EDKOR 10L/15L	400	10L	15L	34.0	19	27	7.5x1.5	12x2
EDKOR 10L/16S	500	10L	16S	39.0	19	30	7.5x1.5	12x2
EDKOR 12S/12L	400	12S	12L	40.0	24	22	9x1.5	9x1.5
EDKOR 12L/14S	400	12L	14S	38.0	22	27	9x1.5	10x2
EDKOR 12S/14S	630	12S	14S	38.0	24	27	9x1.5	10x2
EDKOR 12L/15L	400	12L	15L	36.0	22	27	9x1.5	12x2
EDKOR 12S/15L	400	12S	15L	35.0	24	27	9x1.5	12x2
EDKOR 12L/16S	400	12L	16S	38.0	22	30	9x1.5	12x2
EDKOR 12S/16S	630	12S	16S	38.0	24	30	9x1.5	12x2
EDKOR 12L/18L	400	12L	18L	36.0	22	32	9x1.5	15x2
EDKOR 12L/20S	400	12L	20S	44.0	22	36	9x1.5	16.3x2.4
EDKOR 14S/16S	630	14S	16S	42.0	27	30	10x2	12x2

Please see "Engineering and technical data - Selecting the correct tube fitting" for more information on pressure.

# TUBE FITTINGS

STRAIGHT FITTINGS AND REDUCERS (CONTINUED)



## EDKOR STRAIGHT REDUCER FITTING TAPER

Taper on both ends and O-ring to DIN 3865.

O-ring NBR (e.g. Perbunan), FKM (e.g. Viton) upon request.

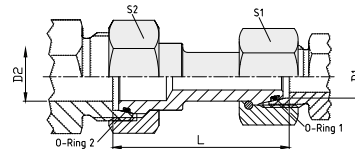

description	PB	pipe D <sub>1</sub>	pipe D <sub>2</sub>	L (± 2 mm)	S <sub>1</sub>	S <sub>2</sub>	O-Ring 1	O-Ring 2
EDKOR 15L/16S	400	15L	16S	39.0	27	30	12x2	12x2
EDKOR 15L/18L	400	15L	18L	38.0	27	32	12x2	15x2
EDKOR 15L/20S	400	15L	20S	44.0	27	36	12x2	16.3x2.4
EDKOR 15L/22L	250	15L	22L	42.0	27	36	12x2	20x2
EDKOR 15L/25S	400	15L	25S	50.0	27	46	12x2	20.3x2.4
EDKOR 16S/18L	400	16S	18L	41.0	30	32	12x2	15x2
EDKOR 16S/20S	400	16S	20S	47.0	30	36	12x2	16.3x2.4
EDKOR 16S/22L	250	16S	22L	44.0	30	36	12x2	20x2
EDKOR 16S/25S	400	16S	25S	48.0	30	46	12x2	20.3x2.4
EDKOR 18L/20S	400	18L	20S	46.0	32	36	15x2	16.3x2.4
EDKOR 18L/22L	250	18L	22L	41.0	32	36	15x2	20x2
EDKOR 18L/25S	400	18L	25S	47.0	32	46	15x2	20.3x2.4
EDKOR 18L/28L	250	18L	28L	47.0	32	41	15x2	26x2
EDKOR 18L/30S	400	18L	30S	52.0	32	50	15x2	25.3x2.4
EDKOR 20S/22L	250	20S	22L	46.0	36	36	16.3x2.4	20x2
EDKOR 20S/25S	400	20S	25S	55.0	36	46	16.3x2.4	20.3x2.4
EDKOR 20S/28L	250	20S	28L	50.0	36	41	16.3x2.4	26x2
EDKOR 20S/30S	400	20S	30S	60.0	36	50	16.3x2.4	25.3x2.4
EDKOR 22L/25S	250	22L	25S	47.0	36	46	20x2	20.3x2.4
EDKOR 22L/28L	250	22L	28L	41.0	36	41	20x2	26x2
EDKOR 22L/30S	250	22L	30S	49.0	36	50	20x2	25.3x2.4
EDKOR 22L/35L	250	22L	35L	48.0	36	50	20x2	32x2.5
EDKOR 22L/38S	250	22L	38S	51.0	36	60	20x2	33.3x2.4
EDKOR 25S/28L	250	25S	28L	48.0	46	41	20.3x2.4	26x2
EDKOR 25S/30S	400	25S	30S	57.0	46	50	20.3x2.4	25.3x2.4
EDKOR 25S/35L	250	25S	35L	62.0	46	50	20.3x2.4	32x2.5
EDKOR 25S/38S	400	25S	38S	95.0	46	60	20.3x2.4	33.3x2.4
EDKOR 28L/30S	250	28L	30S	50.0	41	50	26x2	25.3x2.4
EDKOR 28L/35L	250	28L	35L	51.0	41	50	26x2	32x2.5
EDKOR 28L/38S	250	28L	38S	50.0	41	60	26x2	33.3x2.4
EDKOR 28L/42L	250	28L	42L	50.0	41	60	26x2	38x2.5
EDKOR 30S/35L	250	30S	35L	58.0	50	50	25.3x2.4	32x2.5
EDKOR 30S/38S	400	30S	38S	57.0	50	60	25.3x2.4	33.3x2.4
EDKOR 30S/42L	250	30S	42L	58.0	50	60	25.3x2.4	38x2.5
EDKOR 35L/38S	250	35L	38S	57.0	50	60	32x2.5	33.3x2.4
EDKOR 35L/42L	250	35L	42L	59.0	50	60	32x2.5	38x2.5
EDKOR 38S/42L	250	38S	42L	62.0	60	60	33.3x2.4	38x2.5

Please see "Engineering and technical data - Selecting the correct tube fitting" for more information on pressure.

# TUBE FITTINGS

ADJUSTABLE LOCKNUT FITTINGS | BE ADJUSTABLE LOCKNUT ELBOW



## BE ADJUSTABLE LOCKNUT ELBOW METRIC

Metric parallel.

ISO 6149 with O-ring seal.

O-ring NBR (e.g. Perbunan), FKM (e.g. Viton) upon request.

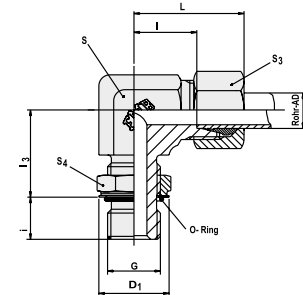

description	pipe OD	PN series	S <sub>4</sub>	S	S <sub>3</sub>	L	I	I <sub>3</sub>	D <sub>1</sub>	i	G	MA* Nm	O-Ring	kg / 100 pcs
BE 4-MLL/O	4	LL 250	12	11	10	21	11.5	19.8	13.3	7.1	M 8x1		6.1x1.6	2.5
BE 4-MLL/M10x1/O	4		14	11	10	21	11.5	19.8	15.3	7.1	M 10x1		8.1x1.6	2.9
BE 6-MLL/O	6		14	11	12	22	9.5	19.8	15.3	7.1	M 10x1		8.1x1.6	2.8
BE 6-MLL/M12x1.5/O	6		17	14	12	25	12.5	23.2	18.6	9.6	M 12x1.5		9.3x2.2	4.9
DS-BE 6-ML/O	6	L 315	14	14	14	29	14.0	20.0	15.0	7.0	M 10x1	15	8.1x1.6	6.6
DS-BE 8-ML/O	8		17	14	17	31	16.0	22.0	18.0	10.0	M 12x1.5	25	9.3x2.2	6.6
DS-BE 10-ML/O	10		19	19	19	32	17.0	25.0	20.0	10.0	M 14x1.5	35	11.3x2.2	8.7
DS-BE 12-ML/O	12		22	19	22	34	19.0	26.0	23.0	10.0	M 16x1.5	40	13.3x2.2	9.5
DS-BE 15-ML/O	15		24	22	27	36	21.0	30.0	25.0	11.0	M 18x1.5	45	15.3x2.2	22.4
DS-BE 18-ML/O	18		27	27	32	40	24.0	33.0	28.0	12.0	M 22x1.5	60	19.3x2.2	28.4
DS-BE 22-ML/O	22	L 160	32	30	36	44	28.0	35.0	33.0	14.0	M 27x2	100	23.6x2.9	53.4
DS-BE 28-ML/O	28		41	36	41	47	31.0	38.0	41.0	14.0	M 33x2	160	29.6x2.9	60.7
DS-BE 35-ML/O	35		50	50	50	59	38.0	48.0	51.0	14.0	M 42x2	210	38.6x2.9	84.4
DS-BE 42-ML/O	42		55	50	60	61	38.0	49.0	56.0	16.0	M 48x2	260	44.6x2.9	92.8
DS-BE 6-MS/O	6	S 400	17	14	17	30	15.0	22.0	18.0	10.0	M 12x1.5	35	9.3x2.2	7.2
DS-BE 8-MS/O	8		19	19	19	32	17.0	26.0	20.0	10.0	M 14x1.5	45	11.3x2.2	8.8
DS-BE 10-MS/O	10		22	19	22	34	18.0	27.0	23.0	11.0	M 16x1.5	55	13.3x2.2	9.7
DS-BE 12-MS/O	12		24	22	24	38	22.0	31.0	25.0	12.0	M 18x1.5	70	15.3x2.2	22.7
DS-BE 16-MS/O	16		27	27	30	43	25.0	35.0	28.0	14.0	M 22x1.5	100	19.3x2.2	28.6
DS-BE 20-MS/O	20		32	30	36	49	28.0	39.0	33.0	16.0	M 27x2	170	23.6x2.9	55.3
DS-BE 25-MS/O	25	S 315	41	36	46	54	30.0	44.0	41.0	16.0	M 33x2	310	29.6x2.9	72.2
DS-BE 30-MS/O	30	S 250	50	50	50	62	36.0	51.0	51.0	17.0	M 42x2	330	38.6x2.9	93.2
DS-BE 38-MS/O	38	S 200	55	50	60	65	34.0	54.0	56.0	19.0	M 48x2	420	44.6x2.9	104.2

\* Recommended tightening torques for stud threads G, with mating material steel

Please see "Engineering and technical data - Selecting the correct tube fitting" for more information on pressure.

# TUBE FITTINGS

ADJUSTABLE LOCKNUT FITTINGS | BE ADJUSTABLE LOCKNUT ELBOW



## BE ADJUSTABLE LOCKNUT ELBOW UNF/UN

UNF / UN parallel with O-ring seal.

O-ring NBR (e.g. Perbunan), FKM (e.g. Viton) upon request.

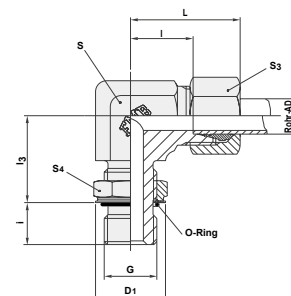

description	pipe OD	PN series	S <sub>4</sub>	S	S <sub>3</sub>	L	l	l <sub>3</sub>	D <sub>1</sub>	i	G	MA* Nm	O-Ring	kg / 100 pcs
DS-BE 6-L/7/16-20UNF	6	L 315	14	14	14	29	14	19	16.5	10	7/16-20UNF-2A	19	8.92x1.83	6.5
DS-BE 8-L/7/16-20UNF	8		14	14	17	31	16	19	16.5	10	7/16-20UNF-2A	19	8.92x1.83	7.0
DS-BE 10-L/9/16-18UNF	10		17	19	19	32	17	24	20.2	11	9/16-18UNF-2A	40	11.89x1.98	9.0
DS-BE 12-L/9/16-18UNF	12		17	19	22	34	19	25	20.2	11	9/16-18UNF-2A	40	11.89x1.98	11.0
DS-BE 12-L/3/4-16UNF	12		22	19	22	34	19	25	25.7	13	3/4-16UNF-2A	60	16.36x2.21	19.4
DS-BE 15-L/3/4-16UNF	15		22	22	27	36	21	28	25.7	13	3/4-16UNF-2A	60	16.36x2.21	18.5
DS-BE 15-L/7/8-14UNF	15		27	22	27	36	21	28	29.3	15	7/8-14UNF-2A	80	19.18x2.46	18.8
DS-BE 18-L/7/8-14UNF	18		27	27	32	40	24	32	29.3	15	7/8-14UNF-2A	80	19.18x2.46	28.4
DS-BE 18-L/1 1/16-12UN	18	L 160	32	30	32	40	24	32	36.7	17	1 1/16-12UN-2A	110	23.47x2.95	31.8
DS-BE 22-L/1 1/16-12UN	22		32	30	36	44	28	35	36.7	17	1 1/16-12UN-2A	110	23.47x2.95	53.5
DS-BE 28-L/1 5/8-12UN	28		41	36	41	47	31	42	44.0	17	1 5/8-12UN-2A	160	29.74x2.95	45.2
DS-BE 35-L/1 5/8-12UN	35		50	50	50	59	38	46	55.0	17	1 5/8-12UN-2A	300	37.46x3	84.4
DS-BE 42-L/1 7/8-12UN	42	55	50	60	61	38	47	62.3	17	1 7/8-12UN-2A	340	43.69x3	92.8	
DS-BE 6-S/7/16-20UNF	6	S 400	14	14	17	30	15	20	16.5	11	7/16-20UNF-2A	21	8.92x1.83	6.5
DS-BE 8-S/9/16-18UNF	8		17	19	19	32	17	25	20.2	12	9/16-18UNF-2A	50	11.89x1.98	8.5
DS-BE 10-S/9/16-18UNF	10		17	19	22	34	18	26	20.2	12	9/16-18UNF-2A	50	11.89x1.98	9.0
DS-BE 12-S/3/4-16UNF	12		22	22	24	38	22	30	25.7	14	3/4-16UNF-2A	80	16.36x2.21	21.3
DS-BE 16-S/7/8-14UNF	16		27	27	30	43	25	34	29.3	16	7/8-14UNF-2A	140	19.18x2.46	28.6
DS-BE 20-S/1 1/16-12UN	20		32	30	36	49	28	37	36.7	19	1 1/16-12UN-2A	190	23.47x2.95	55.5
DS-BE 25-S/1 1/16-12UN	25		32	36	46	54	30	50	36.7	19	1 1/16-12UN-2A	190	23.47x2.95	69.4
DS-BE 30-S/1 5/8-12UN	30		50	50	50	62	36	50	55.0	19	1 5/8-12UN-2A	350	37.46x3	93.2
DS-BE 38-S/1 7/8-12UN	38	55	50	60	65	34	51	62.3	19	1 7/8-12UN-2A	430	43.69x3	104.2	

\* Recommended tightening torques for stud threads G. with mating material steel  
Please see "Engineering and technical data - Selecting the correct tube fitting" for more information on pressure.



# TUBE FITTINGS

ADJUSTABLE LOCKNUT FITTINGS | BE ADJUSTABLE LOCKNUT ELBOW



## BE ADJUSTABLE LOCKNUT ELBOW BSP RR

BSP parallel for small or wide spot face.

Retaining ring and O-ring NBR (e.g. Perbunan), FKM (e.g. Viton) upon request.

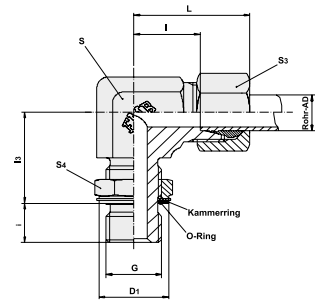

description	pipe OD	PN series	S <sub>4</sub>	S	S <sub>3</sub>	L	l	l <sub>3</sub>	D <sub>1</sub>	i	G	MA* Nm	O-Ring	Support ring small	kg / 100 pcs
BE 4-RL/OA	4	LL 250	14	11	10	21	11.3	20.5	15	5.5	G 1/8"A	10	8x1.88	KAM R1/3	3.0
BE 6-RL/OA	6		14	11	12	21	11.3	20.5	15	5.5	G 1/8"A	10	8x1.88	KAM R1/8	3.2
DS-BE 6-RL/OA	6	L 315	14	14	14	29	14.0	20.5	15	5.5	G 1/8 A	25	8x1.88	KAM R1/8	6.6
DS-BE 8-RL/OA	8		19	14	17	31	16.0	25.5	20	7.0	G 1/4"A	50	10.77x2.62	KAM R1/4	6.6
DS-BE 10-RL/OA	10	L 250	19	19	19	32	17.0	27.0	20	7.0	G 1/4" A	50	10.77x2.62	KAM R1/4	11.9
DS-BE 12-RL/OA	12		22	19	22	34	19.0	30.0	23	7.0	G 3/8" A	80	13.94x2.62	KAM R3/8	13.8
DS-BE 15-RL/OA	15	L 250	27	22	27	36	21.0	32.5	28	10.5	G 1/2" A	105	17x3	KAM R1/2	28.3
DS-BE 18-RL/OA	18		27	27	32	40	24.0	38.5	28	10.5	G 1/2" A	105	17x3	KAM R1/2	34.4
DS-BE 22-RL/OA	22	L 160	36	30	36	44	28.0	38.5	33	10.5	G 3/4"A	220	23.6x2.9	KAM R3/4	44.9
DS-BE 28-RL/OA	28		41	36	41	47	31.0	46.5	41	12.5	G 1"A	370	29.74x3.53	KAM R1	65.7
DS-BE 35-RL/OA	35		50	50	50	59	38.0	52.5	51	12.5	G 1 1/4"A	500	37.69x3.53	KAM R1 1/4	111.3
DS-BE 42-RL/OA	42	S 315	55	50	60	61	38.0	54.5	56	12.5	G 1 1/2"A	600	44.04x3.53	KAM R1 1/2	119.7
DS-BE 6-RS/OA	6		19	14	17	30	15.0	25.0	20	7.0	G 1/4"A	50	10.77x2.62	KAM R1/4	6.9
DS-BE 8-RS/OA	8	S 250	19	19	19	32	17.0	27.0	20	7.0	G 1/4"A	50	10.77x2.62	KAM R1/4	12.0
DS-BE 10-RS/OA	10		22	19	22	34	18.0	30.0	23	7.0	G 3/8"A	80	13.94x2.62	KAM R3/8	13.8
DS-BE 12-RS/OA	12	S 250	22	22	24	38	22.0	30.0	23	7.0	G 3/8"A	80	13.94x2.62	KAM R3/8	20.6
DS-BE 16-RS/OA	16		27	27	30	43	25.0	38.5	28	10.5	G 1/2"A	105	17x3	KAM R1/2	34.6
DS-BE 20-RS/OA	20	S 160	36	30	36	49	28.0	38.5	33	10.5	G 3/4"A	220	23.6x2.9	KAM R3/4	46.8
DS-BE 25-RS/OA	25		41	36	46	54	30.0	46.5	41	12.5	G 1"A	370	29.74x3.53	KAM R1	77.2
DS-BE 30-RS/OA	30	S 160	50	50	50	62	36.0	51.5	51	12.5	G 1 1/4"A	500	37.69x3.53	KAM R1 1/4	106.9
DS-BE 38-RS/OA	38		55	50	60	65	34.0	57.5	56	12.5	G 1 1/2"A	600	44.04x3.53	KAM R1 1/2	131.1

\* Recommended tightening torques for stud threads G. with mating material steel

Please see "Engineering and technical data - Selecting the correct tube fitting" for more information on pressure.

# TUBE FITTINGS

ADJUSTABLE LOCKNUT FITTINGS | BE ADJUSTABLE LOCKNUT ELBOW

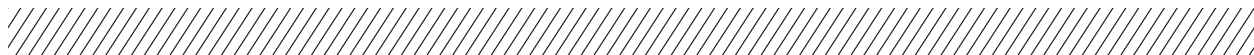

## BE ADJUSTABLE LOCKNUT ELBOW METRIC RR

Metric parallel for small or wide spot face.

Retaining ring and O-ring NBR (e.g. Perbunan), FKM (e.g. Viton) upon request.

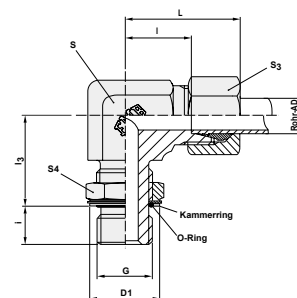

description	pipe OD	PN series	S <sub>4</sub>	S	S <sub>3</sub>	L	I	I <sub>3</sub>	D <sub>1</sub>	i	G	MA* Nm	O-Ring	Support ring small	kg / 100 pcs
DS-BE 6-ML/OA	6	L 315	14	14	14	29	14	21.5	15	5.5	M10x1	18	8x1.88	KAM M10x1	6.6
DS-BE 8-ML/OA	8		17	14	17	31	16	23.5	18	8.5	M12x1.5	35	9.3x2.2	KAM M12x1.5	6.6
DS-BE 10-ML/OA	10		19	19	19	32	17	26.5	20	8.5	M14x1.5	55	11.3x2.2	KAM M14x1.5	8.7
DS-BE 12-ML/OA	12		22	19	22	34	19	27.5	23	8.5	M16x1.5	80	13.3x2.2	KAM M16x1.5	9.5
DS-BE 15-ML/OA	15	L 250	24	22	27	36	21	32.0	25	9.0	M18x1.5	105	15.54x2.62	KAM M18x1.5	22.4
DS-BE 18-ML/OA	18		27	27	32	40	24	35.5	28	9.5	M22x1.5	125	19.2x3	KAM M22x1.5	28.4
DS-BE 22-ML/OA	22		32	30	36	44	28	37.5	33	11.5	M27x2	220	23.47x2.95	KAM M27x2	53.4
DS-BE 28-ML/OA	28		41	36	41	47	31	40.5	41	11.5	M33x2	370	29.2x3	KAM M33x2	60.9
DS-BE 35-ML/OA	35	L 160	50	50	50	59	38	50.5	51	11.5	M42x2	500	37.69x3.53	KAM M42x2	84.4
DS-BE 42-ML/OA	42		55	50	60	61	38	51.5	56	13.5	M48x2	600	43.69x3	KAM M48x2	92.4
DS-BE 6-MS/OA	6	S 315	17	14	17	30	15	23.5	18	8.5	M12x1.5	35	9.3x2.2	KAM M12x1.5	7.2
DS-BE 8-MS/OA	8		19	19	19	32	17	27.5	20	8.5	M14x1.5	55	11.3x2.2	KAM M14x1.5	8.8
DS-BE 10-MS/OA	10		22	19	22	34	18	28.5	23	9.5	M16x1.5	80	13.3x2.2	KAM M16x1.5	9.7
DS-BE 12-MS/OA	12		24	22	24	38	22	33.0	25	10.0	M18x1.5	105	15.54x2.62	KAM M18x1.5	22.7
DS-BE 16-MS/OA	16	S 250	27	27	30	43	25	37.5	28	11.5	M22x1.5	125	19.2x3	KAM M22x1.5	28.6
DS-BE 20-MS/OA	20		32	30	36	49	28	41.5	33	13.5	M27x2	220	23.47x2.95	KAM M27x2	55.3
DS-BE 25-MS/OA	25	S 160	41	36	46	54	30	46.5	41	13.5	M33x2	370	29.2x3	KAM M33x2	72.2
DS-BE 30-MS/OA	30		50	50	50	62	36	53.5	51	14.5	M42x2	500	37.69x3.53	KAM M42x2	93.2
DS-BE 38-MS/OA	38		55	50	60	65	34	56.5	56	16.5	M48x2	600	43.69x3	KAM M48x2	104.2

\* Recommended tightening torques for stud threads G. with mating material steel

Please see "Engineering and technical data - Selecting the correct tube fitting" for more information on pressure.

# TUBE FITTINGS

ADJUSTABLE LOCKNUT FITTINGS | BFE ADJUSTABLE 45° LOCKNUT ELBOW



## BFE ADJUSTABLE 45° LOCKNUT ELBOW METRIC

Metric parallel.

ISO 6149 with O-ring seal.

O-ring NBR (e.g. Perbunan), FKM (e.g. Viton) upon request.

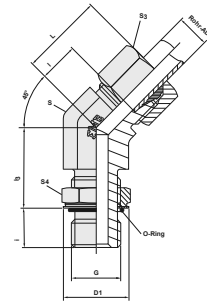

description	pipe OD	PN series	S <sub>4</sub>	S	S <sub>3</sub>	L	l	l <sub>3</sub>	D <sub>1</sub>	i	G	MA* Nm	O-Ring	kg / 100 pcs
DS-BFE 6-ML/O	6	L 315	14	14	14	24	9	19	15	7	M10x1	15	8.1x1.6	9.3
DS-BFE 8-ML/O	8		17	14	17	27	12	19	18	10	M12x1.5	25	9.3x2.2	10.3
DS-BFE 10-ML/O	10		19	19	19	27	12	24	20	10	M14x1.5	35	11.3x2.2	17.5
DS-BFE 12-ML/O	12		22	19	22	28	14	24	23	10	M16x1.5	40	13.3x2.2	19.1
DS-BFE 15-ML/O	15		24	22	27	32	17	24	25	11	M18x1.5	45	15.3x2.2	33.1
DS-BFE 18-ML/O	18		27	27	32	33	17	30	28	12	M22x1.5	60	19.3x2.2	42.3
DS-BFE 22-ML/O	22	L 160	32	30	36	35	19	33	33	14	M27x2	100	23.6x2.9	73.7
DS-BFE 28-ML/O	28		41	36	41	40	23	35	41	14	M33x2	160	29.6x2.9	77.7
DS-BFE 35-ML/O	35		50	50	50	48	27	37	51	14	M42x2	210	38.6x2.9	126.0
DS-BFE 42-ML/O	42	S 400	55	50	60	49	26	37	56	16	M48x2	260	44.6x2.9	142.8
DS-BFE 6-MS/O	6		17	14	17	24	9	18	18	10	M12x1.5	35	9.3x2.2	10.6
DS-BFE 8-MS/O	8		19	19	19	27	12	21	20	10	M14x1.5	45	11.3x2.2	17.7
DS-BFE 10-MS/O	10		22	19	22	29	13	21	23	11	M16x1.5	55	13.3x2.2	19.5
DS-BFE 12-MS/O	12		24	22	24	33	17	22	25	12	M18x1.5	70	15.3x2.2	31.3
DS-BFE 16-MS/O	16		27	27	30	34	16	29	28	14	M22x1.5	100	19.3x2.2	42.7
DS-BFE 20-MS/O	20	S 250	32	30	36	38	16	31	33	16	M27x2	170	23.6x2.9	77.5
DS-BFE 25-MS/O	25		41	36	46	43	19	33	41	16	M33x2	310	29.6x2.9	100.7
DS-BFE 30-MS/O	30	S 200	50	50	50	50	24	35	51	17	M42x2	330	38.6x2.9	143.6
DS-BFE 38-MS/O	38		55	50	60	52	21	35	56	19	M48x2	420	44.6x2.9	165.6

\* Recommended tightening torques for stud threads G. with mating material steel

Please see "Engineering and technical data - Selecting the correct tube fitting" for more information on pressure.

# TUBE FITTINGS

ADJUSTABLE LOCKNUT FITTINGS | BFE ADJUSTABLE 45° LOCKNUT ELBOW

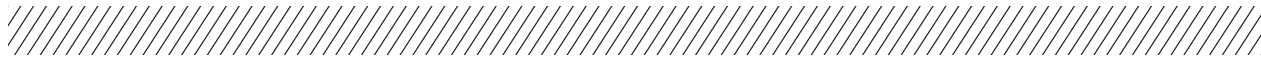

## BFE ADJUSTABLE 45° LOCKNUT ELBOW UNF/UN

UNF / UN parallel with O-ring seal.

O-ring NBR (e.g. Perbunan), FKM (e.g. Viton) upon request.

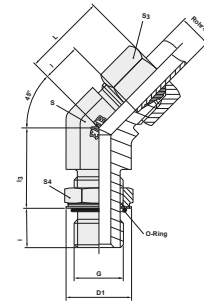

description	pipe OD	PN series	S <sub>4</sub>	S	S <sub>3</sub>	L	l	l <sub>3</sub>	D <sub>1</sub>	i	G	MA* Nm	O-Ring	kg / 100 pcs
DS-BFE 6-L/7/16-20UNF	6	L 315	14	14	14	24	9	19	16.5	10	7/16-20UNF-2A	19	8.92x1.83	5.7
DS-BFE 8-L/7/16-20UNF	8		14	14	17	27	12	19	16.5	10	7/16-20UNF-2A	19	8.92x1.83	6.2
DS-BFE 10-L/9/16-18UNF	10		17	19	19	27	12	24	20.2	11	9/16-18UNF-2A	40	11.89x1.98	10.5
DS-BFE 12-L/9/16-18UNF	12		17	19	22	28	14	24	20.2	11	9/16-18UNF-2A	40	11.89x1.98	10.1
DS-BFE 12-L/3/4-16UNF	12		22	19	22	28	14	24	25.7	13	3/4-16UNF-2A	60	16.36x2.21	14.7
DS-BFE 15-L/3/4-16UNF	15		22	22	27	32	17	24	25.7	13	3/4-16UNF-2A	60	16.36x2.21	20.3
DS-BFE 15-L/7/8-14UNF	15		27	22	27	32	17	24	29.3	15	7/8-14UNF-2A	80	19.18x2.46	18.0
DS-BFE 18-L/7/8-14UNF	18		27	27	32	33	17	30	29.3	15	7/8-14UNF-2A	80	19.18x2.46	26.4
DS-BFE 18-L/1 1/6-12UN	18	L 160	32	30	32	33	17	30	36.7	17	1 1/16-12UN-2A	110	23.47x2.95	36.4
DS-BFE 22-L/1 1/6-12UN	22		32	30	36	35	19	33	36.7	17	1 1/16-12UN-2A	110	23.47x2.95	38.8
DS-BFE 28-L/1 5/8-12UN	28		41	36	41	39	23	35	44.0	17	1 5/8-12UN-2A	160	29.74x2.95	50.0
DS-BFE 35-L/1 5/8-12UN	35		50	50	50	48	27	37	55.0	17	1 5/8-12UN-2A	300	37.46x3	73.1
DS-BFE 42-L/1 7/8-12UN	42		55	50	60	49	26	37	62.3	17	1 7/8-12UN-2A	340	43.69x3	81.5
DS-BFE 6-S/7/16-20UNF	6	S 400	14	14	17	24	9	18	16.5	11	7/16-20UNF-2A	21	8.92x1.83	6.5
DS-BFE 8-S/9/16-18UNF	8		17	19	19	27	12	21	20.2	12	9/16-18UNF-2A	50	11.89x1.98	10.6
DS-BFE 10-S/9/16-18UNF	10		17	19	22	29	13	21	20.2	12	9/16-18UNF-2A	50	11.89x1.98	11.5
DS-BFE 12-S/3/4-16UNF	12		22	22	24	33	17	22	25.7	14	3/4-16UNF-2A	80	16.36x2.21	17.1
DS-BFE 16-S/7/8-14UNF	16		27	27	30	34	16	29	29.3	16	7/8-14UNF-2A	140	19.18x2.46	26.6
DS-BFE 20-S/1 1/16-12UN	20		32	30	36	38	16	31	36.7	19	1 1/16-12UN-2A	190	23.47x2.95	40.7
DS-BFE 25-S/1 1/16-12UN	25		32	36	46	43	19	33	36.7	19	1 1/16-12UN-2A	190	23.47x2.95	55.8
DS-BFE 30-S/1 5/8-12UN	30		50	50	50	50	24	35	55.0	19	1 5/8-12UN-2A	350	37.46x3	81.9
DS-BFE 38-S/1 7/8-12UN	38	55	50	60	52	21	35	62.3	19	1 7/8-12UN-2A	430	43.69x3	92.9	

\* Recommended tightening torques for stud threads G. with mating material steel  
Please see "Engineering and technical data - Selecting the correct tube fitting" for more information on pressure.

# TUBE FITTINGS

ADJUSTABLE LOCKNUT FITTINGS | BFE ADJUSTABLE 45° LOCKNUT ELBOW



## BFE ADJUSTABLE 45° LOCKNUT ELBOW BSP RR

BSP parallel for small or wide spot face.

Retaining ring and O-ring NBR (e.g. Perbunan), FKM (e.g. Viton) upon request.

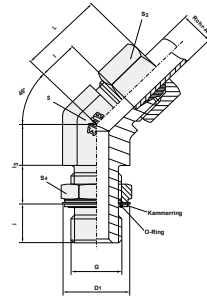

description	pipe OD	PN series	S <sub>4</sub>	S	S <sub>3</sub>	L	l	l <sub>3</sub>	D <sub>1</sub>	i	G	MA* Nm	O-Ring	Support ring small	kg / 100 pcs
DS-BFE 6-RL/OA	6	L 315	14	4	14	24	9	24.5	15	5.5	G 1/8"A	25	8x1.88	KAM R1/8	9.3
DS-BFE 8-RL/OA	8		19	14	17	27	12	21.0	20	7.0	G 1/4"A	50	10.77x2.62	KAM R1/4	10.3
DS-BFE 10-RL/OA	10		19	19	19	27	12	25.0	20	7.0	G 1/4"A	50	10.77x2.62	KAM R1/4	17.1
DS-BFE 12-RL/OA	12	L 250	22	19	22	28	14	27.0	23	7.0	G 3/8"A	80	13.94x2.62	KAM R3/8	20.6
DS-BFE 15-RL/OA	15		27	22	27	32	17	27.5	28	10.5	G 1/2"A	105	17x3	KAM R1/2	31.3
DS-BFE 18-RL/OA	18		27	27	32	33	17	33.5	28	10.5	G 1/2"A	105	17x3	KAM R1/2	42.8
DS-BFE 22-RL/OA	22	L 160	36	30	36	35	19	36.5	33	10.5	G 3/4"A	220	23.6x2.9	KAM R3/4	71.9
DS-BFE 28-RL/OA	28		41	36	41	40	23	39.5	41	12.5	G 1"A	370	29.74x3.53	KAM R1	81.2
DS-BFE 35-RL/OA	35		50	50	50	48	27	40.5	51	12.5	G 1 1/4"A	500	37.69x3.53	KAM R11/4	126.0
DS-BFE 42-RL/OA	42	S 315	55	50	60	49	26	40.5	56	12.5	G 1 1/2"A	600	44.04x3.53	KAM R11/2	142.8
DS-BFE 6-RS/OA	6		19	14	17	24	9	21.0	20	7.0	G 1/4"A	50	10.77x2.62	KAM R1/4	10.9
DS-BFE 8-RS/OA	8		19	19	19	27	12	25.0	20	7.0	G 1/4"A	50	10.77x2.62	KAM R1/4	15.3
DS-BFE 10-RS/OA	10	S 250	22	19	22	29	13	27.0	23	7.0	G 3/8"A	80	13.94x2.62	KAM R3/8	19.1
DS-BFE 12-RS/OA	12		22	22	24	33	17	27.0	23	7.0	G 3/8"A	80	13.94x2.62	KAM R3/8	23.8
DS-BFE 16-RS/OA	16		27	27	30	34	16	33.5	28	10.5	G 1/2"A	105	17x3	KAM R1/2	43.2
DS-BFE 20-RS/OA	20	S 160	36	30	36	38	16	36.5	33	10.5	G 3/4"A	220	23.6x2.9	KAM R3/4	75.7
DS-BFE 25-RS/OA	25		41	36	46	43	19	39.5	41	12.5	G 1"A	370	29.74x3.53	KAM R1	104.2
DS-BFE 30-RS/OA	30		50	50	50	50	24	40.5	51	12.5	G 1 1/4"A	500	37.69x3.53	KAM R11/4	143.6
DS-BFE 38-RS/OA	38	55	50	60	52	21	40.5	56	12.5	G 1 1/2"A	600	44.04x3.53	KAM R11/2	165.6	

\* Recommended tightening torques for stud threads G. with mating material steel  
Please see "Engineering and technical data - Selecting the correct tube fitting" for more information on pressure.

# TUBE FITTINGS

ADJUSTABLE LOCKNUT FITTINGS | BFE ADJUSTABLE 45° LOCKNUT ELBOW



## BFE ADJUSTABLE 45° LOCKNUT ELBOW METRIC RR

Metric parallel for small or wide spot face.

Retaining ring and O-ring NBR (e.g. Perbunan), FKM (e.g. Viton) upon request.

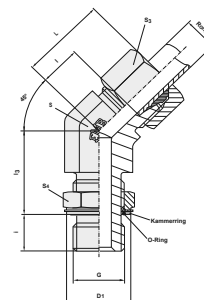

description	pipe OD	PN series	S <sub>4</sub>	S	S <sub>3</sub>	L	l	l <sub>3</sub>	D <sub>1</sub>	i	G	MA* Nm	O-Ring	Support ring small	kg / 100 pcs
DS-BFE 6-ML/OA	6	L 315	14	14	14	24	9	20.5	15	5.5	M10x1	18	8x1.88	KAM M10x1	5.7
DS-BFE 8-ML/OA	8		17	14	17	27	12	20.5	18	8.5	M12x1.5	35	9.3x2.2	KAM M12x1.5	6.2
DS-BFE 10-ML/OA	10		19	19	19	27	12	25.5	20	8.5	M14x1.5	55	11.3x2.2	KAM M14x1.5	10.4
DS-BFE 12-ML/OA	12		22	19	22	28	14	25.5	23	8.5	M16x1.5	80	13.3x2.2	KAM M16x1.5	14.0
DS-BFE 15-ML/OA	15		24	22	27	32	17	26.0	25	9.0	M18x1.5	105	15.54x2.62	KAM M18x1.5	19.8
DS-BFE 18-ML/OA	18	L 250	27	27	32	33	17	32.5	28	9.5	M22x1.5	125	19.2x3	KAM M22x1.5	26.0
DS-BFE 22-ML/OA	22	L 160	32	30	36	35	19	35.5	33	11.5	M27x2	220	23.47x2.95	KAM M27x2	38.2
DS-BFE 28-ML/OA	28		41	36	41	40	23	37.5	41	11.5	M33x2	370	29.2x3	KAM M33x2	40.6
DS-BFE 35-ML/OA	35		50	50	50	48	27	39.5	51	11.5	M42x2	500	37.69x3.53	KAM M42x2	72.9
DS-BFE 42-ML/OA	42	L 160	55	50	60	49	26	39.5	56	13.5	M48x2	600	43.69x3	KAM M48x2	81.3
DS-BFE 6-MS/OA	6	S 315	17	14	17	24	9	19.5	18	8.5	M12x1.5	35	9.3x2.2	KAM M12x1.5	6.4
DS-BFE 8-MS/OA	8		19	19	19	27	12	22.5	20	8.5	M14x1.5	55	11.3x2.2	KAM M14x1.5	10.5
DS-BFE 10-MS/OA	10		22	19	22	29	13	22.5	23	9.5	M16x1.5	80	13.3x2.2	KAM M16x1.5	11.4
DS-BFE 12-MS/OA	12		24	22	24	33	17	24.0	25	10.0	M18x1.5	105	15.54x2.62	KAM M18x1.5	14.9
DS-BFE 16-MS/OA	16	S 250	27	27	30	34	16	31.5	28	11.5	M22x1.5	125	19.2x3	KAM M22x1.5	22.2
DS-BFE 20-MS/OA	20		32	30	36	38	16	33.5	33	13.5	M27x2	220	23.47x2.95	KAM M27x2	40.1
DS-BFE 25-MS/OA	25		41	36	46	43	19	35.5	41	13.5	M33x2	370	29.2x3	KAM M33x2	52.1
DS-BFE 30-MS/OA	30	S 160	50	50	50	50	24	37.5	51	14.5	M42x2	500	37.69x3.53	KAM M42x2	81.7
DS-BFE 38-MS/OA	38		55	50	60	52	21	37.5	56	16.5	M48x2	600	43.69x3	KAM M48x2	92.7

\* Recommended tightening torques for stud threads G. with mating material steel

Please see "Engineering and technical data - Selecting the correct tube fitting" for more information on pressure.

# TUBE FITTINGS

ADJUSTABLE LOCKNUT FITTINGS | CE ADJUSTABLE LOCKNUT BRANCH TEE



## CE ADJUSTABLE LOCKNUT BRANCH TEE METRIC

Metric parallel.

ISO 6149 with O-ring seal.

O-ring NBR (e.g. Perbunan), FKM (e.g. Viton) upon request.

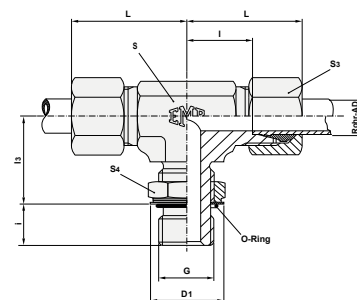

description	pipe OD	PN series	S <sub>4</sub>	S	S <sub>3</sub>	L	I	I <sub>3</sub>	D <sub>1</sub>	i	G	MA* Nm	O-Ring	kg / 100 pcs
DS-CE 6-ML/O	6	L 315	14	14	14	29	14	20	15	7	M 10x1	15	8.1x1.6	9.3
DS-CE 8-ML/O	8		17	14	17	31	16	22	18	10	M 12x1.5	25	9.3x2.2	10.3
DS-CE 10-ML/O	10		19	19	19	32	17	25	20	10	M 14x1.5	35	11.3x2.2	17.5
DS-CE 12-ML/O	12		22	19	22	34	19	26	23	10	M 16x1.5	40	13.3x2.2	19.1
DS-CE 15-ML/O	15		24	22	27	36	21	30	25	11	M 18x1.5	45	15.3x2.2	33.1
DS-CE 18-ML/O	18		27	27	32	40	24	33	28	12	M 22x1.5	60	19.3x2.2	42.3
DS-CE 22-ML/O	22	L 160	32	30	36	44	28	35	33	14	M 27x2	100	23.6x2.9	73.7
DS-CE 28-ML/O	28		41	36	41	47	31	38	41	14	M 33x2	160	29.6x2.9	77.7
DS-CE 35-ML/O	35		50	50	50	59	38	48	51	14	M 42x2	210	38.6x2.9	126.0
DS-CE 42-ML/O	42	S 400	55	50	60	61	38	49	56	16	M 48x2	260	44.6x2.9	142.8
DS-CE 6-MS/O	6		17	14	17	30	15	22	18	10	M 12x1.5	35	9.3x2.2	10.6
DS-CE 8-MS/O	8		19	19	19	32	17	26	20	10	M 14x1.5	45	11.3x2.2	17.7
DS-CE 10-MS/O	10		22	19	22	34	18	27	23	11	M 16x1.5	55	13.3x2.2	19.5
DS-CE 12-MS/O	12		24	22	24	38	22	31	25	12	M 18x1.5	70	15.3x2.2	31.3
DS-CE 16-MS/O	16		27	27	30	43	25	35	28	14	M 22x1.5	100	19.3x2.2	42.7
DS-CE 20-MS/O	20	S 315	32	30	36	49	28	39	33	16	M 27x2	170	23.6x2.9	77.5
DS-CE 25-MS/O	25		41	36	46	54	30	44	41	16	M 33x2	310	29.6x2.9	100.7
DS-CE 30-MS/O	30	S 250	50	50	50	62	36	51	51	17	M 42x2	330	38.6x2.9	143.6
DS-CE 38-MS/O	38	S 200	55	50	60	65	34	54	56	19	M 48x2	420	44.6x2.9	165.6

\* Recommended tightening torques for stud threads G. with mating material steel

Please see "Engineering and technical data - Selecting the correct tube fitting" for more information on pressure.

# TUBE FITTINGS

ADJUSTABLE LOCKNUT FITTINGS | CE ADJUSTABLE LOCKNUT BRANCH TEE



## CE ADJUSTABLE LOCKNUT BRANCH TEE UNF/UN

UNF / UN parallel with O-ring seal.

O-ring NBR (e.g. Perbunan), FKM (e.g. Viton) upon request.

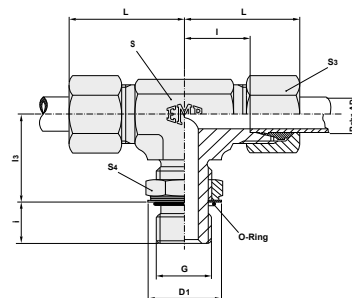

description	pipe OD	PN series	S <sub>4</sub>	S	S <sub>3</sub>	L	l	l <sub>3</sub>	D <sub>1</sub>	i	G	MA* Nm	O-Ring	kg / 100 pcs
DS-CE 6-L/7/16-20UNF	6	L 315	14	14	14	29	14	19	16.5	10	7/16-20UNF-2A	19	8.92x1.83	9.1
DS-CE 8-L/7/16-20UNF	8		14	14	17	31	16	19	16.5	10	7/16-20UNF-2A	19	8.92x1.83	10.1
DS-CE 10-L/9/16-18UNF	10		17	19	19	32	17	24	20.2	11	9/16-18UNF-2A	40	11.89x1.98	17.5
DS-CE 12-L/9/16-18UNF	12		17	19	22	34	19	25	20.2	11	9/16-18UNF-2A	40	11.89x1.98	19.5
DS-CE 12-L/3/4-16UNF	12		22	19	22	34	19	25	25.7	13	3/4-16UNF-2A	60	16.36x2.21	24.7
DS-CE 15-L/3/4-16UNF	15		22	22	27	36	21	28	25.7	13	3/4-16UNF-2A	60	16.36x2.21	32.9
DS-CE 15-L/7/8-14UNF	15		27	22	27	36	21	28	29.3	15	7/8-14UNF-2A	80	19.18x2.46	32.9
DS-CE 18-L/7/8-14UNF	18		27	27	32	40	24	32	29.3	15	7/8-14UNF-2A	80	19.18x2.46	41.9
DS-CE 18-L/1 1/6-12UN	18	L 160	32	30	32	40	24	32	36.7	17	1 1/16-12UN-2A	110	23.47x2.95	58.1
DS-CE 22-L/1 1/6-12UN	22		32	30	36	44	28	35	36.7	17	1 1/16-12UN-2A	110	23.47x2.95	62.9
DS-CE 28-L/1 5/8-12UN	28		41	36	41	47	31	42	44.0	17	1 5/8-12UN-2A	160	29.74x2.95	75.1
DS-CE 35-L/1 5/8-12UN	35		50	50	50	59	38	46	55.0	17	1 5/8-12UN-2A	300	37.46x3	126.2
DS-CE 42-L/1 7/8-12UN	42	55	50	60	61	38	47	62.3	17	1 7/8-12UN-2A	340	43.69x3	148.2	
DS-CE 6-S/7/16-20UNF	6	S 400	14	14	17	30	15	20	16.5	11	7/16-20UNF-2A	21	8.92x1.83	10.7
DS-CE 8-S/9/16-18UNF	8		17	19	19	32	17	25	20.2	12	9/16-18UNF-2A	50	11.89x1.98	17.7
DS-CE 10-S/9/16-18UNF	10		17	19	22	34	18	26	20.2	12	9/16-18UNF-2A	50	11.89x1.98	19.5
DS-CE 12-S/3/4-16UNF	12		22	22	24	38	22	30	25.7	14	3/4-16UNF-2A	80	16.36x2.21	31.1
DS-CE 16-S/7/8-14UNF	16		27	27	30	43	25	34	29.3	16	7/8-14UNF-2A	140	19.18x2.46	42.3
DS-CE 20-S/1 1/16-12UN	20		32	30	36	49	28	37	36.7	19	1 1/16-12UN-2A	190	23.47x2.95	66.7
DS-CE 25-S/1 1/16-12UN	25		32	36	46	54	30	50	36.7	19	1 1/16-12UN-2A	190	23.47x2.95	98.1
DS-CE 30-S/1 5/8-12UN	30		50	50	50	62	36	50	55.0	19	1 5/8-12UN-2A	350	37.46x3	143.8
DS-CE 38-S/1 7/8-12UN	38	55	50	60	65	34	51	63.0	19	1 7/8-12UN-2A	430	43.69x3	165.8	

\* Recommended tightening torques for stud threads G. with mating material steel  
Please see "Engineering and technical data - Selecting the correct tube fitting" for more information on pressure.



# TUBE FITTINGS

ADJUSTABLE LOCKNUT FITTINGS | CE ADJUSTABLE LOCKNUT BRANCH TEE



## CE ADJUSTABLE LOCKNUT BRANCH TEE BSP RR

BSP parallel for small or wide spot face.

Retaining ring and O-ring NBR (e.g. Perbunan), FKM (e.g. Viton) upon request.

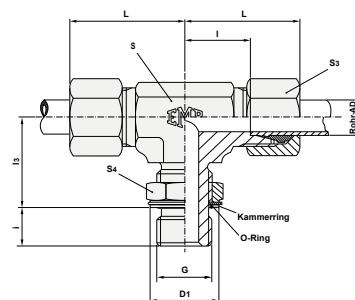

description	pipe OD	PN series	S <sub>4</sub>	S	S <sub>3</sub>	L	I	I <sub>3</sub>	D <sub>1</sub>	i	G	MA* Nm	O-Ring	Support ring small	kg / 100 pcs
DS-CE 6-RL/OA	6	L 315	14	14	14	29	14	20.5	15	5.5	G 1/8"A	25	8x1.88	KAM R1/8	9.3
DS-CE 8-RL/OA	8		19	14	17	31	16	25.0	20	7.0	G 1/4"A	50	10.77x2.62	KAM R1/4	10.3
DS-CE 10-RL/OA	10		19	19	19	32	17	27.0	20	7.0	G 1/4"A	50	10.77x2.62	KAM R1/4	17.1
DS-CE 12-RL/OA	12	L 250	22	19	22	34	19	30.0	23	7.0	G 3/8"A	80	13.94x2.62	KAM R3/8	20.6
DS-CE 15-RL/OA	15		27	22	27	36	21	32.5	28	10.5	G 1/2"A	105	17x3	KAM R1/2	31.3
DS-CE 18-RL/OA	18		27	27	32	40	24	38.5	28	10.5	G 1/2"A	105	17x3	KAM R1/2	42.8
DS-CE 22-RL/OA	22	L 160	36	30	36	44	28	38.5	33	10.5	G 3/4"A	220	23.6x2.9	KAM R3/4	71.9
DS-CE 28-RL/OA	28		41	36	41	47	31	46.5	41	12.5	G 1"A	370	29.74x3.53	KAM R1	81.2
DS-CE 35-RL/OA	35		50	50	50	59	38	52.5	51	12.5	G 1 1/4"A	500	37.69x3.53	KAM R11/4	126.0
DS-CE 42-RL/OA	42	S 315	55	50	60	61	38	54.5	56	12.5	G 1 1/2"A	600	44.04x3.53	KAM R11/2	142.8
DS-CE 6-RS/OA	6		19	14	17	30	15	25.0	20	7.0	G 1/4"A	50	10.77x2.62	KAM R1/4	10.9
DS-CE 8-RS/OA	8		19	19	19	32	17	27.0	20	7.0	G 1/4"A	50	10.77x2.62	KAM R1/4	15.3
DS-CE 10-RS/OA	10	S 250	22	19	22	34	18	30.0	23	7.0	G 3/8"A	80	13.94x2.62	KAM R3/8	19.1
DS-CE 12-RS/OA	12		22	22	24	38	22	30.0	23	7.0	G 3/8"A	80	13.94x2.62	KAM R3/8	23.8
DS-CE 16-RS/OA	16		27	27	30	43	25	38.5	28	10.5	G 1/2"A	105	17x3	KAM R1/2	43.2
DS-CE 20-RS/OA	20	S 160	36	30	36	49	28	38.5	33	10.5	G 3/4"A	220	23.6x2.9	KAM R3/4	75.7
DS-CE 25-RS/OA	25		41	36	46	54	30	46.5	41	12.5	G 1"A	370	29.74x3.53	KAM R1	104.2
DS-CE 30-RS/OA	30		50	50	50	62	36	51.5	51	12.5	G 1 1/4"A	500	37.69x3.53	KAM R11/4	143.6
DS-CE 38-RS/OA	38	55	50	60	65	34	57.5	56	12.5	G 1 1/2"A	600	44.04x3.53	KAM R11/2	165.6	

\* Recommended tightening torques for stud threads G. with mating material steel

Please see "Engineering and technical data - Selecting the correct tube fitting" for more information on pressure.

# TUBE FITTINGS

ADJUSTABLE LOCKNUT FITTINGS | CE ADJUSTABLE LOCKNUT BRANCH TEE

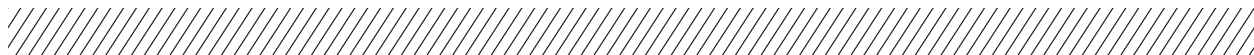

## CE ADJUSTABLE LOCKNUT BRANCH TEE METRIC RR

Metric parallel for small or wide spot face.

Retaining ring and O-ring NBR (e.g. Perbunan), FKM (e.g. Viton) upon request.

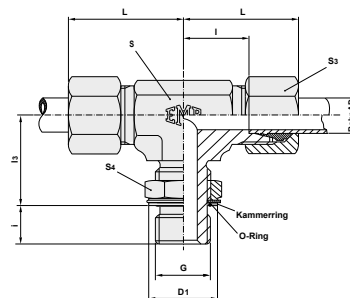

description	pipe OD	PN series	S <sub>4</sub>	S	S <sub>3</sub>	L	I	I <sub>3</sub>	D <sub>1</sub>	i	G	MA* Nm	O-Ring	Support ring small	kg / 100 pcs
DS-CE 6-ML/OA	6	L 315	14	14	14	29	14	21.5	15	5.5	M 10x1	18	8x1.88	KAM M10x1	9.3
DS-CE 8-ML/OA	8		17	14	17	31	16	23.5	18	8.5	M 12x1.5	35	9.3x2.2	KAM M12x1.5	10.3
DS-CE 10-ML/OA	10		19	19	19	32	17	26.5	20	8.5	M 14x1.5	55	11.3x2.2	KAM M14x1.5	17.5
DS-CE 12-ML/OA	12		22	19	22	34	19	27.5	23	8.5	M 16x1.5	80	13.3x2.2	KAM M16x1.5	19.1
DS-CE 15-ML/OA	15		24	22	27	36	21	32.0	25	9.0	M 18x1.5	105	15.54x2.62	KAM M18x1.5	33.1
DS-CE 18-ML/OA	18	L 250	27	27	32	40	24	35.5	28	9.5	M 22x1.5	125	19.2x3	KAM M22x1.5	42.3
DS-CE 22-ML/OA	22	L 160	32	30	36	44	28	37.5	33	11.5	M 27x2	220	23.47x2.95	KAM M27x2	73.7
DS-CE 28-ML/OA	28		41	36	41	47	31	40.5	41	11.5	M 33x2	370	29.2x3	KAM M33x2	77.7
DS-CE 35-ML/OA	35		50	50	50	59	38	50.5	51	11.5	M 42x2	500	37.69x3.53	KAM M42x2	126.0
DS-CE 42-ML/OA	42		55	50	60	61	38	51.5	56	13.5	M 48x2	600	43.69x3	KAM M48x2	142.8
DS-CE 6-MS/OA	6		S 315	17	14	17	30	15	23.5	18	8.5	M 12x1.5	35	9.3x2.2	KAM M12x1.5
DS-CE 8-MS/OA	8	19		19	19	32	17	27.5	20	8.5	M 14x1.5	55	11.3x2.2	KAM M14x1.5	17.7
DS-CE 10-MS/OA	10	22		19	22	34	18	28.5	23	9.5	M 16x1.5	80	13.3x2.2	KAM M16x1.5	19.5
DS-CE 12-MS/OA	12	24		22	24	38	22	33.0	25	10.0	M 18x1.5	105	15.54x2.62	KAM M18x1.5	31.3
DS-CE 16-MS/OA	16	S 250		27	27	30	43	25	37.5	28	11.5	M 22x1.5	125	19.2x3	KAM M22x1.5
DS-CE 20-MS/OA	20		32	30	36	49	28	41.5	33	13.5	M 27x2	220	23.47x2.95	KAM M27x2	77.5
DS-CE 25-MS/OA	25		41	36	46	54	30	46.5	41	13.5	M 33x2	370	29.2x3	KAM M33x2	100.7
DS-CE 30-MS/OA	30	S 160	50	50	50	62	36	53.5	51	14.5	M 42x2	500	37.69x3.53	KAM M42x2	143.6
DS-CE 38-MS/OA	38		55	50	60	65	34	56.5	56	16.5	M 48x2	600	43.69x3	KAM M48x2	165.6

\* Recommended tightening torques for stud threads G, with mating material steel

Please see "Engineering and technical data - Selecting the correct tube fitting" for more information on pressure.

# TUBE FITTINGS

ADJUSTABLE LOCKNUT FITTINGS | DE ADJUSTABLE LOCKNUT RUN TEE



## DE ADJUSTABLE LOCKNUT RUN TEE METRIC

Metric parallel.

ISO 6149 with O-ring seal.

O-ring NBR (e.g. Perbunan), FKM (e.g. Viton) upon request.

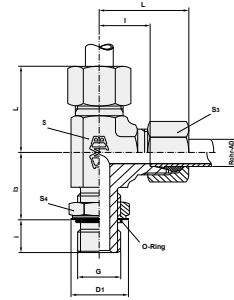

description	pipe OD	PN series	S <sub>4</sub>	S	S <sub>3</sub>	L	l	l <sub>3</sub>	D <sub>1</sub>	i	G	MA* Nm	O-Ring	kg / 100 pcs
DS-DE 6-ML/O	6	L 315	14	14	14	29	14	20	15	7	M 10x1	15	8.1x1.6	9.3
DS-DE 8-ML/O	8		17	14	17	31	16	22	18	10	M 12x1.5	25	9.3x2.2	10.3
DS-DE 10-ML/O	10		19	19	19	32	17	25	20	10	M 14x1.5	35	11.3x2.2	17.5
DS-DE 12-ML/O	12		22	19	22	34	19	26	23	10	M 16x1.5	40	13.3x2.2	19.1
DS-DE 15-ML/O	15		24	22	27	36	21	30	25	11	M 18x1.5	45	15.3x2.2	33.1
DS-DE 18-ML/O	18		27	27	32	40	24	33	28	12	M 22x1.5	60	19.3x2.2	42.3
DS-DE 22-ML/O	22	L 160	32	30	36	44	28	35	33	14	M 27x2	100	23.6x2.9	73.7
DS-DE 28-ML/O	28		41	36	41	47	31	38	41	14	M 33x2	160	29.6x2.9	77.7
DS-DE 35-ML/O	35		50	50	50	59	38	48	51	14	M 42x2	210	38.6x2.9	126.0
DS-DE 42-ML/O	42	S 400	55	50	60	61	38	49	56	16	M 48x2	260	44.6x2.9	142.8
DS-DE 6-MS/O	6		17	14	17	30	15	22	18	10	M 12x1.5	35	9.3x2.2	10.6
DS-DE 8-MS/O	8		19	19	19	32	17	26	20	10	M 14x1.5	45	11.3x2.2	17.7
DS-DE 10-MS/O	10		22	19	22	34	18	27	23	11	M 16x1.5	55	13.3x2.2	19.5
DS-DE 12-MS/O	12		24	22	24	38	22	31	25	12	M 18x1.5	70	15.3x2.2	31.3
DS-DE 16-MS/O	16		27	27	30	43	25	35	28	14	M 22x1.5	100	19.3x2.2	42.7
DS-DE 20-MS/O	20	S 250	32	30	36	49	28	39	33	16	M 27x2	170	23.6x2.9	77.5
DS-DE 25-MS/O	25		41	36	46	54	30	44	41	16	M 33x2	310	29.6x2.9	100.7
DS-DE 30-MS/O	30	S 200	50	50	50	62	36	51	51	17	M 42x2	330	38.6x2.9	143.6
DS-DE 38-MS/O	38		55	50	60	65	34	54	56	19	M 48x2	420	44.6x2.9	165.6

\* Recommended tightening torques for stud threads G. with mating material steel

Please see "Engineering and technical data - Selecting the correct tube fitting" for more information on pressure.

# TUBE FITTINGS

ADJUSTABLE LOCKNUT FITTINGS | DE ADJUSTABLE LOCKNUT RUN TEE



## DE ADJUSTABLE LOCKNUT RUN TEE UNF/UN

UNF / UN parallel with O-ring seal.

ISO 6149 with O-ring seal.

O-ring NBR (e.g. Perbunan), FKM (e.g. Viton) upon request.

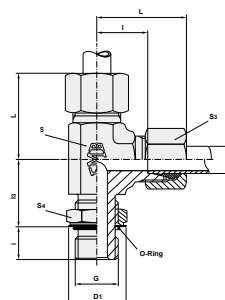

description	pipe OD	PN series	S <sub>4</sub>	S	S <sub>3</sub>	L	I	I <sub>3</sub>	D <sub>1</sub>	i	G	MA* Nm	O-Ring	kg / 100 pcs	
DS-DE 6-L/7/16-20UNF	6	L 315	14	14	14	29	14	19	16.5	10	7/16-20UNF-2A	19	8.92x1.83	9.1	
DS-DE 8-L/7/16-20UNF	8		14	14	17	31	16	19	16.5	10	7/16-20UNF-2A	19	8.92x1.83	10.1	
DS-DE 10-L/9/16-18UNF	10		17	19	19	32	17	24	20.2	11	9/16-18UNF-2A	40	11.89x1.98	17.5	
DS-DE 12-L/9/16-18UNF	12		17	19	22	34	19	25	20.2	11	9/16-18UNF-2A	40	11.89x1.98	19.5	
DS-DE 12-L/3/4-16UNF	12		22	19	22	34	19	25	25.7	13	3/4-16UNF-2A	60	16.36x2.21	24.7	
DS-DE 15-L/3/4-16UNF	15		22	22	27	36	21	28	25.7	13	3/4-16UNF-2A	60	16.36x2.21	32.9	
DS-DE 15-L/7/8-14UNF	15		27	22	27	36	21	28	29.3	15	7/8-14UNF-2A	80	19.18x2.46	32.9	
DS-DE 18-L/7/8-14UNF	18		27	27	32	40	24	32	29.3	15	7/8-14UNF-2A	80	19.18x2.46	41.9	
DS-DE 18-L/1 1/6-12UN	18		32	30	32	40	24	32	36.7	17	1 1/16-12UN-2A	110	23.47x2.95	58.1	
DS-DE 22-L/1 1/6-12UN	22		32	30	36	44	28	35	36.7	17	1 1/16-12UN-2A	110	23.47x2.95	62.9	
DS-DE 28-L/1 5/8-12UN	28	L 160	41	36	41	47	31	42	44.0	17	1 5/16-12UN-2A	160	29.74x2.95	75.1	
DS-DE 35-L/1 5/8-12UN	35		50	50	50	59	38	46	55.0	17	1 5/8-12UN-2A	300	37.46x3	126.2	
DS-DE 42-L/1 7/8-12UN	42		55	50	60	61	38	47	62.3	17	1 7/8-12UN-2A	340	43.69x3	148.2	
DS-DE 6-S/7/16-20UNF	6		14	14	17	30	15	20	16.5	11	7/16-20UNF-2A	21	8.92x1.83	10.7	
DS-DE 8-S/9/16-18UNF	8	S 400	17	19	19	32	17	25	20.2	12	9/16-18UNF-2A	50	11.89x1.98	17.7	
DS-DE 10-S/9/16-18UNF	10		17	19	22	34	18	26	20.2	12	9/16-18UNF-2A	50	11.89x1.98	19.5	
DS-DE 12-S/3/4-16UNF	12		22	22	24	38	22	30	25.7	14	3/4-16UNF-2A	80	16.36x2.21	31.1	
DS-DE 16-S/7/8-14UNF	16		27	27	30	43	25	34	29.3	16	7/8-14UNF-2A	140	19.18x2.46	42.3	
DS-DE 20-S/1 1/16-12UN	20		32	30	36	49	28	37	36.7	19	1 1/16-12UN-2A	190	23.47x2.95	66.7	
DS-DE 25-S/1 1/16-12UN	25		32	36	46	54	30	50	36.7	19	1 1/16-12UN-2A	190	23.47x2.95	98.1	
DS-DE 30-S/1 5/8-12UN	30		S 250	50	50	50	62	36	50	55.0	19	1 5/8-12UN-2A	350	37.46x3	143.8
DS-DE 38-S/1 7/8-12UN	38			55	50	60	65	34	51	63.0	19	1 7/8-12UN-2A	430	43.69x3	165.8

\* Recommended tightening torques for stud threads G, with mating material steel  
Please see "Engineering and technical data - Selecting the correct tube fitting" for more information on pressure.

# TUBE FITTINGS

ADJUSTABLE LOCKNUT FITTINGS | DE ADJUSTABLE LOCKNUT RUN TEE

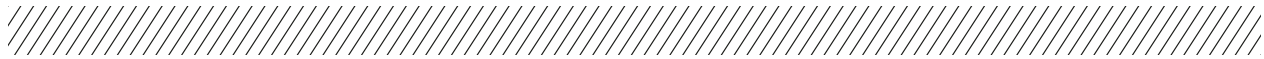

## DE ADJUSTABLE LOCKNUT RUN TEE BSP RR

BSP parallel for small or wide spot face.

Retaining ring and O-ring NBR (e.g. Perbunan),  
FKM (e.g. Viton) upon request.

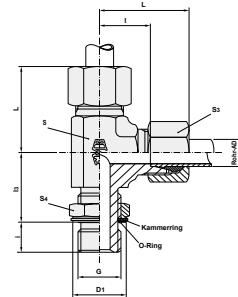

description	pipe OD	PN series	S <sub>4</sub>	S	S <sub>3</sub>	L	I	I <sub>3</sub>	D <sub>1</sub>	i	G	MA* Nm	O-Ring	Support ring small	kg / 100 pcs
DS-DE 6-RL/OA	6	L 315	14	14	14	29	14	20.5	15	5.5	G 1/8"A	25	8x1.88	KAM R1/8	9.3
DS-DE 8-RL/OA	8		19	14	17	31	16	25.0	20	7.0	G 1/4"A	50	10.77x2.62	KAM R1/4	10.3
DS-DE 10-RL/OA	10		19	19	19	32	17	27.0	20	7.0	G 1/4"A	50	10.77x2.62	KAM R1/4	17.1
DS-DE 12-RL/OA	12	L 250	22	19	22	34	19	30.0	23	7.0	G 3/8"A	80	13.94x2.62	KAM R3/8	20.6
DS-DE 15-RL/OA	15		27	22	27	36	21	32.5	28	10.5	G 1/2"A	105	17x3	KAM R1/2	31.3
DS-DE 18-RL/OA	18		27	27	32	40	24	38.5	28	10.5	G 1/2"A	105	17x3	KAM R1/2	42.8
DS-DE 22-RL/OA	22	L 160	36	30	36	44	28	38.5	33	10.5	G 3/4"A	220	23.6x2.9	KAM R3/4	71.9
DS-DE 28-RL/OA	28		41	36	41	47	31	46.5	41	12.5	G 1"A	370	29.74x3.53	KAM R1	81.2
DS-DE 35-RL/OA	35		50	50	50	59	38	52.5	51	12.5	G 1 1/4"A	500	37.69x3.53	KAM R11/4	126.0
DS-DE 42-RL/OA	42	S 315	55	50	60	61	38	54.5	56	12.5	G 1 1/2"A	600	44.04x3.53	KAM R11/2	142.8
DS-DE 6-RS/OA	6		19	14	17	30	15	25.0	20	7.0	G 1/4"A	50	10.77x2.62	KAM R1/4	10.9
DS-DE 8-RS/OA	8		19	19	19	32	17	27.0	20	7.0	G 1/4"A	50	10.77x2.62	KAM R1/4	15.3
DS-DE 10-RS/OA	10	S 250	22	19	22	34	18	30.0	23	7.0	G 3/8"A	80	13.94x2.62	KAM R3/8	19.1
DS-DE 12-RS/OA	12		22	22	24	38	22	30.0	23	7.0	G 3/8"A	80	13.94x2.62	KAM R3/8	23.8
DS-DE 16-RS/OA	16		27	27	30	43	25	38.5	28	10.5	G 1/2"A	105	17x3	KAM R1/2	43.2
DS-DE 20-RS/OA	20	S 160	36	30	36	49	28	38.5	33	10.5	G 3/4"A	220	23.6x2.9	KAM R3/4	75.7
DS-DE 25-RS/OA	25		41	36	46	54	30	46.5	41	12.5	G 1"A	370	29.74x3.53	KAM R1	104.2
DS-DE 30-RS/OA	30		50	50	50	62	36	51.5	51	12.5	G 1 1/4"A	500	37.69x3.53	KAM R11/4	143.6
DS-DE 38-RS/OA	38		55	50	60	65	34	57.5	56	12.5	G 1 1/2"A	600	44.04x3.53	KAM R11/2	165.6

\* Recommended tightening torques for stud threads G. with mating material steel

Please see "Engineering and technical data - Selecting the correct tube fitting" for more information on pressure.

# TUBE FITTINGS

ADJUSTABLE LOCKNUT FITTINGS | DE ADJUSTABLE LOCKNUT RUN TEE



## DE ADJUSTABLE LOCKNUT RUN TEE METRIC RR

Metric parallel for small or wide spot face.

Retaining ring and O-ring NBR (e.g. Perbunan), FKM (e.g. Viton) upon request.

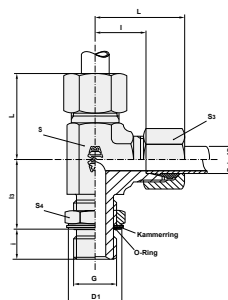

description	pipe OD	PN series	S <sub>4</sub>	S	S <sub>3</sub>	L	l	l <sub>3</sub>	D <sub>1</sub>	i	G	MA* Nm	O-Ring	Support ring small	kg / 100 pcs
DS-DE 6-ML/OA	6	L 315	14	14	14	29	14	21.5	15	5.5	M 10x1	18	8x1.88	KAM M10x1	9.3
DS-DE 8-ML/OA	8		17	14	17	31	16	23.5	18	8.5	M 12x1.5	35	9.3x2.2	KAM M12x1.5	10.3
DS-DE 10-ML/OA	10		19	19	19	32	17	26.5	20	8.5	M 14x1.5	55	11.3x2.2	KAM M14x1.5	17.5
DS-DE 12-ML/OA	12		22	19	22	34	19	27.5	23	8.5	M 16x1.5	80	13.3x2.2	KAM M16x1.5	19.1
DS-DE 15-ML/OA	15	L 250	24	22	27	36	21	32.0	25	9.0	M 18x1.5	105	15.54x2.62	KAM M18x1.5	33.1
DS-DE 18-ML/OA	18		27	27	32	40	24	35.5	28	9.5	M 22x1.5	125	19.2x3	KAM M22x1.5	42.3
DS-DE 22-ML/OA	22	L 160	32	30	36	44	28	37.5	33	11.5	M 27x2	220	23.47x2.95	KAM M27x2	73.7
DS-DE 28-ML/OA	28		41	36	41	47	31	40.5	41	11.5	M 33x2	370	29.2x3	KAM M33x2	77.7
DS-DE 35-ML/OA	35		50	50	50	59	38	50.5	51	11.5	M 42x2	500	37.69x3.53	KAM M42x2	126.0
DS-DE 42-ML/OA	42		55	50	60	61	38	51.5	56	13.5	M 48x2	600	43.69x3	KAM M48x2	142.8
DS-DE 6-MS/OA	6	S 315	17	14	17	30	15	23.5	18	8.5	M 12x1.5	35	9.3x2.2	KAM M12x1.5	10.6
DS-DE 8-MS/OA	8		19	19	19	32	17	27.5	20	8.5	M 14x1.5	55	11.3x2.2	KAM M14x1.5	17.7
DS-DE 10-MS/OA	10		22	19	22	34	18	28.5	23	9.5	M 16x1.5	80	13.3x2.2	KAM M16x1.5	19.5
DS-DE 12-MS/OA	12		24	22	24	38	22	33.0	25	10.0	M 18x1.5	105	15.54x2.62	KAM M18x1.5	31.3
DS-DE 16-MS/OA	16	S 250	27	27	30	43	25	37.5	28	11.5	M 22x1.5	125	19.2x3	KAM M22x1.5	42.7
DS-DE 20-MS/OA	20		32	30	36	49	28	41.5	33	13.5	M 27x2	220	23.47x2.95	KAM M27x2	77.5
DS-DE 25-MS/OA	25	S 160	41	36	46	54	30	46.5	41	13.5	M 33x2	370	29.2x3	KAM M33x2	100.7
DS-DE 30-MS/OA	30		50	50	50	62	36	53.5	51	14.5	M 42x2	500	37.69x3.53	KAM M42x2	143.6
DS-DE 38-MS/OA	38		55	50	60	65	34	56.5	56	16.5	M 48x2	600	43.69x3	KAM M48x2	165.6

\* Recommended tightening torques for stud threads G, with mating material steel

Please see "Engineering and technical data - Selecting the correct tube fitting" for more information on pressure.



**DRIVEN BY POSSIBILITY™**

# **3. PIPE CONNECTIONS**

# PIPE CONNECTIONS

GAUGE FITTINGS



## O GAUGE FITTING BSP

BSP parallel.

With sealing ring DK1.

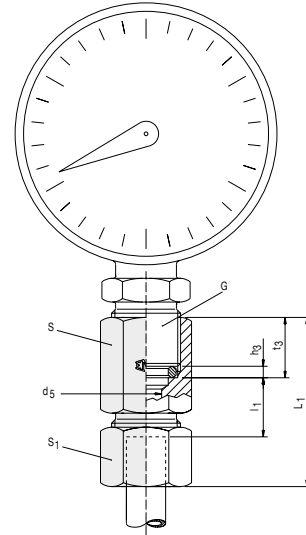

description	pipe OD	PN series	S <sub>1</sub>	S	L <sub>1</sub>	l <sub>1</sub>	G	d <sub>5</sub>	t <sub>3</sub>	h <sub>3</sub>	kg / 100 pcs
DS-O 6-L	6	L 400 (1700)	14	19	37	7.5	G 1/4"	2.5	14.5	4.5	4.6
DS-O 8-L	8		17	19	37	7.5	G 1/4"	5.5	14.5	4.5	5.3
DS-O 10-L	10		19	19	38	8.5	G 1/4"	5.5	14.5	4.5	6.2
DS-O 12-L	12		22	19	38	8.5	G 1/4"	5.5	14.5	4.5	7.0
DS-O 6-S	6	S 630 (2700)	17	27	46	11.0	G 1/2"	3.5	20.0	5.0	10.5
DS-O 8-S	8		19	27	46	11.0	G 1/2"	3.5	20.0	5.0	10.7
DS-O 10-S	10		22	27	47	10.5	G 1/2"	7.0	20.0	5.0	12.5
DS-O 12-S	12		24	27	47	10.5	G 1/2"	7.0	20.0	5.0	13.4

L<sub>1</sub> = approximate length, with nut tightened

Please see "Engineering and technical data - Selecting the correct tube fitting" for more information on pressure.



# PIPE CONNECTIONS

GAUGE FITTINGS

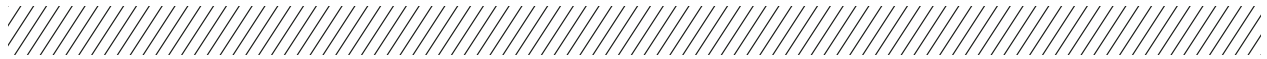

## VODKO GAUGE FITTING TAPER

With taper, sealing ring DKI and O-ring according to DIN 3865.

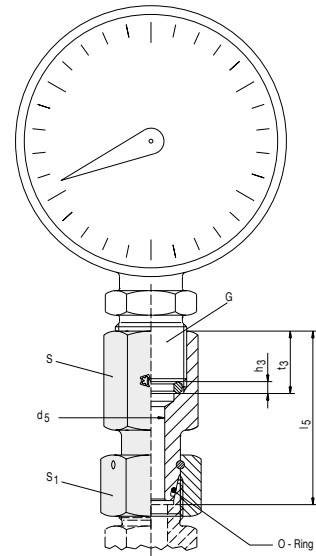

description	pipe OD	PN series	$l_5$	$d_5$	$t_3$	S	$S_1$	$h_3$	G	O-ring	kg / 100 pcs
VODKO 6-L	6	L 400 (1700)	38.0	2.5	14.5	19	17	4.5	G 1/4"	4x1.5	4.6
VODKO 8-L	8		38.0	4.0	14.5	19	17	4.5	G 1/4"	6x1.5	5.3
VODKO 10-L	10		39.5	5.5	14.5	19	19	4.5	G 1/4"	7.5x1.5	6.2
VODKO 12-L	12		40.5	5.5	14.5	19	22	4.5	G 1/4"	9x1.5	7.0
VODKO 6-S	6	S 630 (2700)	45.0	2.5	20.0	27	17	5.0	G 1/2"	4x1.5	10.5
VODKO 8-S	8		45.0	4.0	20.0	27	19	5.0	G 1/2"	6x1.5	10.7
VODKO 10-S	10		47.0	6.0	20.0	27	22	5.0	G 1/2"	7.5x1.5	12.5
VODKO 12-S	12		47.5	7.0	20.0	27	24	5.0	G 1/2"	9x1.5	13.4

Please see "Engineering and technical data - Selecting the correct tube fitting" for more information on pressure.

# PIPE CONNECTIONS

FEMALE STUD FITTINGS



## AI FEMALE STUD FITTING BSP

BSP parallel.

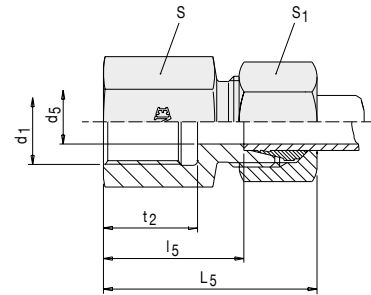

description	pipe OD	PB series	$l_5$	$d_5$	$L_5$	S	$S_1$	$t_2$	G	kg / 100 pcs
DS-AI 6-L/R 1/8"	6	L 315 (863)	19.0	4	34	14	14	12.0	G 1/8"	2.5
DS-AI 8-L/R 1/4"	8		24.0	6	39	19	17	17.0	G 1/4"	4.5
DS-AI 10-L/R 1/4"	10		25.0	8	40	19	19	17.0	G 1/4"	5.5
DS-AI 12-L/R 3/8"	12		26.0	10	41	24	22	17.0	G 3/8"	9.0
DS-AI 15-L/R 1/2"	15		31.0	12	46	27	27	20.0	G 1/2"	13.0
DS-AI 18-L/R 1/2"	18		30.5	15	47	27	32	20.0	G 1/2"	15.0
DS-AI 22-L/R 3/4"	22	L 160 (400)	35.5	19	52	36	36	22.0	G 3/4"	25.5
DS-AI 28-L/R 1"	28		38.0	24	55	41	41	24.5	G 1"	30.0
DS-AI 35-L/R 1 1/4"	35		41.0	30	63	55	50	26.5	G 1 1/4"	42.0
DS-AI 42-L/R 1 1/2"	42	S 630 (1575)	42.5	36	65	60	60	28.5	G 1 1/2"	60.5
DS-AI 6-S/R 1/4"	6		26.0	4	41	19	17	17.0	G 1/4"	6.0
DS-AI 8-S/R 1/4"	8		26.0	5	41	19	19	17.0	G 1/4"	6.5
DS-AI 10-S/R 3/8"	10		26.5	7	43	24	22	17.0	G 3/8"	9.0
DS-AI 12-S/R 3/8"	12		26.5	8	43	24	24	17.0	G 3/8"	10.5
DS-AI 14-S/R 1/2"	14		32.0	10	50	27	27	20.0	G 1/2"	13.0
DS-AI 16-S/R 1/2"	16	S 400 (1000)	31.5	12	50	27	30	20.0	G 1/2"	16.0
DS-AI 20-S/R 3/4"	20		34.5	16	56	36	36	22.0	G 3/4"	26.0
DS-AI 25-S/R 1"	25		37.5	20	62	41	46	24.5	G 1"	40.0
DS-AI 30-S/R 1 1/4"	30		42.0	25	69	55	50	26.5	G 1 1/4"	72.0
DS-AI 38-S/R 1 1/2"	38	43.5	32	74	60	60	28.5	G 1 1/2"	85.5	

$L_5$  = approximate length, with nut tightened

Please see "Engineering and technical data - Selecting the correct tube fitting" for more information on pressure.

# PIPE CONNECTIONS

FEMALE STUD FITTINGS



## AI FEMALE STUD FITTING METRIC

Metric parallel.

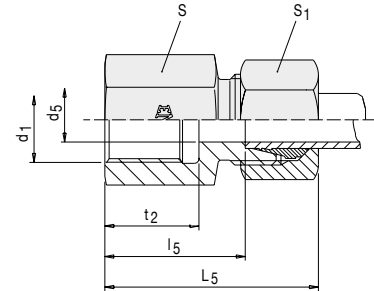

description	pipe OD	PB series	$l_5$	$d_5$	$L_5$	S	$S_1$	$t_2$	G	kg / 100 pcs
DS-AI 6-L/M 10x1	6	L 315 (863)	19.5	4	34	14	14	12.5	M 10x1	2.9
DS-AI 8-L/M 12x1.5	8		24.0	6	39	17	17	17.0	M 12x1.5	4.7
DS-AI 10-L/M 14x1.5	10		25.0	8	40	19	19	17.0	M 14x1.5	5.9
DS-AI 12-L/M 16x1.5	12		26.0	10	41	22	22	17.0	M 16x1.5	7.9
DS-AI 15-L/M 18x1.5	15		28.0	12	43	24	27	17.0	M 18x1.5	11.2
DS-AI 18-L/M 22x1.5	18		29.5	15	46	30	32	19.0	M 22x1.5	17.4
DS-AI 22-L/M 26x1.5	22	L 160 (400)	34.5	19	51	32	36	21.0	M 26x1.5	20.9
DS-AI 28-L/M 33x2	28		37.5	24	54	41	41	24.0	M 33x2	31.2
DS-AI 35-L/M 42x2	35		40.5	30	62	55	50	26.0	M 42x2	57.9
DS-AI 42-L/M 48x2	42	S 630 (1575)	42.0	36	65	60	60	28.0	M 48x2	76.0
DS-AI 6-S/M 12x1.5	6		26.0	4	41	17	17	17.0	M 12x1.5	5.3
DS-AI 8-S/M 14x1.5	8		26.0	5	41	19	19	17.0	M 14x1.5	6.4
DS-AI 10-S/M 16x1.5	10		26.5	7	43	22	22	17.0	M 16x1.5	9.0
DS-AI 12-S/M 18x1.5	12		27.5	8	44	22	24	17.0	M 18x1.5	10.6
DS-AI 14-S/M 20x1.5	14		31.0	10	49	27	27	19.0	M 20x1.5	14.9
DS-AI 16-S/M 22x1.5	16	S 400 (1000)	30.5	12	49	27	30	19.0	M 22x1.5	18.3
DS-AI 20-S/M 27x2	20		34.5	16	56	36	36	22.0	M 27x2	29.9
DS-AI 25-S/M 33x2	25		37.0	20	61	41	46	24.0	M 33x2	45.5
DS-AI 30-S/M 42x2	30		41.5	25	68	55	50	26.0	M 42x2	73.0
DS-AI 38-S/M 48x2	38	43.0	32	74	60	60	28.0	M 48x2	93.8	

$L_5$  = approximate length, with nut tightened

Please see "Engineering and technical data - Selecting the correct tube fitting" for more information on pressure.

# PIPE CONNECTIONS

REDUCING ADAPTORS



## RI REDUCING ADAPTOR

BSP parallel.

Stud face form B.

Other sizes and threads upon request.

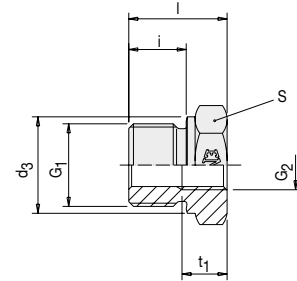

description G1-G2	PB	l	i	S	d <sub>3</sub>	t <sub>1</sub>	kg / 100 pcs	
RI 3/8"- 1/8"	630	22.5	12	22	22	8.0	4.0	
RI 1/2-1/4	400	24.0	14	27	26	8.0	6.0	
RI 1/2-1/8		24.0	14	27	26	12.0	6.0	
RI 3/4-1/4		26.0	16	32	32	12.0	9.5	
RI 3/4-3/8		26.0	16	32	32	12.0	9.0	
RI 1-1/4		29.0	18	41	39	12.0	20.0	
RI 1-3/8		29.0	18	41	39	12.0	18.0	
RI 1-1/2	250	29.0	18	41	39	14.0	16.0	
RI 1 1/4-1/2		32.0	20	50	49	14.0	31.0	
RI 1 1/4-3/4		32.0	20	50	49	16.0	27.0	
RI 1 1/2-1/2		36.0	22	55	55	14.0	47.0	
RI 1 1/2-3/4		36.0	22	55	55	16.0	43.0	
RI 1 1/2-1		36.0	22	55	55	18.0	34.5	
RI 1/8-1/4	630	31.0	8	19	14	17.0	3.6	
RI 1/8-3/8		32.0	8	24	14	17.0	4.5	
RI 1/4-1/8		28.0	12	19	18	12.0	3.6	
RI 1/4-3/8		36.0	12	24	18	17.0	6.6	
RI 1/4-1/2		40.0	12	30	18	20.0	8.5	
RI 1/4-3/4		43.0	12	36	18	22.0	17.3	
RI 3/8-1/4	630	36.0	12	22	22	17.0	3.0	
RI 3/8-1/2		41.0	12	30	22	20.0	9.0	
RI 3/8-3/4		44.0	12	36	22	22.0	17.5	
RI 1/2-3/8		400	36.0	14	27	26	17.0	9.5
RI 1/2-3/4			46.0	14	36	26	22.0	18.0
RI 1/2-1			49.0	14	41	26	24.5	22.5
RI 1/2-1 1/4	250		53.0	14	55	26	26.5	47.0
RI 3/4-1/2	400		41.0	16	32	32	20.0	15.0
RI 3/4-1			51.0	16	41	32	24.5	23.5
RI 3/4-1 1/4		250	55.0	16	55	32	26.5	48.3
RI 3/4-1 1/2		250	57.0	16	60	32	28.5	54.5
RI 1-3/4		400	47.0	18	41	39	22.0	28.0
RI 1-1 1/4			57.0	18	55	39	26.5	51.0
RI 1-1 1/2	59.0		18	60	39	28.5	56.5	
RI 1 1/4-1	250		52.0	20	50	49	24.5	45.5
RI 1 1/4-1 1/2			60.0	20	60	49	28.5	58.0
RI 1 1/2-1 1/4			58.0	22	55	55	26.5	53.0

Please see "Engineering and technical data - Selecting the correct tube fitting" for  
 - reducing example.  
 - more information on pressure.

# PIPE CONNECTIONS

REDUCING ADAPTORS



## RI REDUCING ADAPTOR WITH CAPTIVE SEAL

BSP parallel.

Captive seal O-ring NBR (e.g. Perbunan), FKM (e.g. Viton) upon request.

Other sizes and threads upon request.

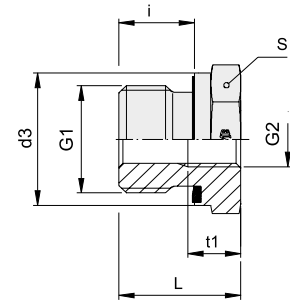

description G1-G2	PB	l	i	S	d <sub>3</sub>	t <sub>1</sub>	kg / 100 pcs	
RI 3/8"WD - 1/8"	630	22.5	12	22	22	8.0	3.9	
RI 1/2"WD - 1/8"		24.0	14	27	27	8.0	6.6	
RI 1/2"WD - 1/4"		24.0	14	27	27	12.0	5.6	
RI 3/4"WD - 1/4"		26.0	16	32	32	12.0	10.3	
RI 3/4"WD - 3/8"		26.0	16	32	32	12.0	8.7	
RI 1"WD - 1/4"	400	29.0	18	41	40	12.0	19.5	
RI 1"WD - 3/8"		29.0	18	41	40	12.0	17.9	
RI 1"WD - 1/2"		29.0	18	41	40	14.0	15.7	
RI 1 1/4"WD - 1/2"		32.0	20	50	50	14.0	30.8	
RI 1 1/4"WD - 3/4"	315	32.0	20	50	50	16.0	26.6	
RI 1 1/2"WD - 1/2"		36.0	22	55	55	14.0	47.0	
RI 1 1/2"WD - 3/4"		36.0	22	55	55	16.0	40.2	
RI 1 1/2"WD - 1"		36.0	22	55	55	18.0	33.7	
RI 1/8"WD - 1/4"		31.0	8	19	14	17.0	3.9	
RI 1/8"WD - 3/8"	630	32.0	8	24	14	17.0	6.3	
RI 1/4"WD - 1/8"		29.0	12	19	19	12.0	3.8	
RI 1/4"WD - 3/8"		36.0	12	24	19	17.0	6.7	
RI 1/4"WD - 1/2"		40.0	12	30	19	20.0	11.6	
RI 1/4"WD - 3/4"		43.0	12	36	19	22.0	17.0	
RI 3/8"WD - 1/4"	400	36.0	12	22	22	17.0	6.8	
RI 3/8"WD - 1/2"		41.0	12	30	22	20.0	14.3	
RI 3/8"WD - 3/4"		44.0	12	36	22	22.0	18.3	
RI 1/2"WD - 3/8"		630	37.0	14	27	27	17.0	9.1
RI 1/2"WD - 3/4"		46.0	14	36	27	22.0	18.2	
RI 1/2"WD - 1"	400	49.0	14	41	27	24.5	22.1	
RI 1/2"WD - 1 1/4"		53.0	14	55	27	26.5	48.2	
RI 3/4"WD - 1/2"		43.0	16	32	32	20.0	14.3	
RI 3/4"WD - 1"		51.0	16	41	32	24.5	23.5	
RI 3/4"WD - 1 1/4"		55.0	16	55	32	26.5	48.1	
RI 3/4"WD - 1 1/2"	315	57.0	16	60	32	28.5	56.0	
RI 1"WD - 3/4"	400	49.0	18	41	40	22.0	26.8	
RI 1"WD - 1 1/4"		57.0	18	55	40	26.5	50.3	
RI 1"WD - 1 1/2"		315	59.0	18	60	40	28.5	58.5
RI 1 1/4"WD - 1"	400	53.0	20	50	50	24.5	45.8	
RI 1 1/4"WD - 1 1/2"	315	60.0	20	60	50	28.5	61.6	
RI 1 1/2"WD - 1 1/4"		58.0	22	55	55	26.5	54.2	

Please see "Engineering and technical data - Selecting the correct tube fitting" for  
 - reducing example.  
 - more information on pressure.

### RL REDUCING CONNECTION

These parts are ready mounted;  
not pre-assembled.

After screwing on by hand, tighten with a spanner  
until tight, and then apply final 30 ° turn.

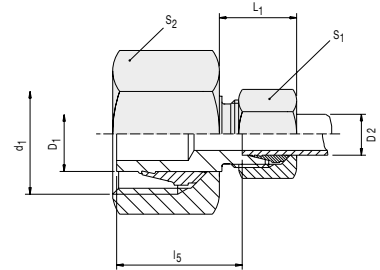

description	pipe OD1	pipe OD2	PN series	L <sub>1</sub>	l <sub>5</sub>	S <sub>1</sub>	S <sub>2</sub>	d <sub>1</sub>	kg / 100 pcs
DS-RL 8/6	8	6	L 500 (2200)	24	23.5	14	17	M 14x1.5	4.0
DS-RL 10/6	10	6		24	23.5	14	19	M 16x1.5	4.7
DS-RL 10/8	10	8		24	23.5	17	19	M 16x1.5	5.2
DS-RL 12/6	12	6		24	23.5	14	22	M 18x1.5	5.9
DS-RL 12/8	12	8		24	23.5	17	22	M 18x1.5	6.3
DS-RL 12/10	12	10		25	24.5	19	22	M 18x1.5	6.9
DS-RL 15/6	15	6		23	23.5	14	27	M 22x1.5	8.2
DS-RL 15/8	15	8		23	23.5	17	27	M 22x1.5	8.9
DS-RL 15/10	15	10		24	24.5	19	27	M 22x1.5	9.3
DS-RL 15/12	15	12		24	24.5	22	27	M 22x1.5	10.0
DS-RL 18/6	18	6	L 400 (1700)	23	24.5	14	32	M 26x1.5	10.8
DS-RL 18/8	18	8		23	24.5	17	32	M 26x1.5	11.0
DS-RL 18/10	18	10		24	25.5	19	32	M 26x1.5	11.7
DS-RL 18/12	18	12		24	25.5	22	32	M 26x1.5	12.5
DS-RL 18/15	18	15		26	26.5	27	32	M 26x1.5	14.9
DS-RL 22/6	22	6		24	25.5	14	36	M 30x2	14.1
DS-RL 22/8	22	8		24	25.5	17	36	M 30x2	14.9
DS-RL 22/10	22	10		25	26.5	19	36	M 30x2	15.1
DS-RL 22/12	22	12		25	26.5	22	36	M 30x2	16.0
DS-RL 22/15	22	15		27	27.5	27	36	M 30x2	18.0
DS-RL 22/18	22	18	27	27.0	32	36	M 30x2	19.8	
DS-RL 28/6	28	6	L 250 (1100)	25	26.5	14	41	M 36x2	18.5
DS-RL 28/8	28	8		25	26.5	17	41	M 36x2	19.3
DS-RL 28/10	28	10		26	27.5	19	41	M 36x2	20.0
DS-RL 28/12	28	12		26	27.5	22	41	M 36x2	20.5
DS-RL 28/15	28	15		27	28.5	27	41	M 36x2	22.5
DS-RL 28/18	28	18		28	28.0	32	41	M 36x2	24.5
DS-RL 28/22	28	22		30	30.0	36	41	M 36x2	26.8
DS-RL 35/6	35	6		25	31.5	14	50	M 45x2	30.8
DS-RL 35/8	35	8		25	31.5	17	50	M 45x2	31.2
DS-RL 35/10	35	10		26	32.5	19	50	M 45x2	32.0
DS-RL 35/12	35	12	26	32.5	22	50	M 45x2	32.0	
DS-RL 35/15	35	15	27	33.5	27	50	M 45x2	34.8	
DS-RL 35/18	35	18	28	33.0	32	50	M 45x2	36.2	
DS-RL 35/22	35	22	30	35.0	36	50	M 45x2	37.8	
DS-RL 35/28	35	28	30	35.0	41	50	M 45x2	39.5	
DS-RL 42/6	42	6	24	32.5	14	60	M 52x2	44.0	
DS-RL 42/8	42	8	24	32.5	17	60	M 52x2	45.0	
DS-RL 42/10	42	10	26	33.5	19	60	M 52x2	45.0	
DS-RL 42/12	42	12	26	33.5	22	60	M 52x2	45.9	
DS-RL 42/15	42	15	27	34.5	27	60	M 52x2	47.0	
DS-RL 42/18	42	18	28	34.0	32	60	M 52x2	48.9	
DS-RL 42/22	42	22	30	36.0	36	60	M 52x2	51.0	
DS-RL 42/28	42	28	30	36.0	41	60	M 52x2	53.0	
DS-RL 42/35	42	35	34	34.0	50	60	M 52x2	58.3	

L<sub>1</sub> = approximate length, with nut tightened

Please see "Engineering and technical data - Selecting the correct tube fitting" for  
- reducing example.

- more information on pressure.

# PIPE CONNECTIONS

## REDUCING CONNECTIONS



### RS REDUCING CONNECTION

These parts are ready mounted;  
not pre-assembled.

After screwing on by hand, tighten with a spanner  
until tight, and then apply final 30 ° turn.

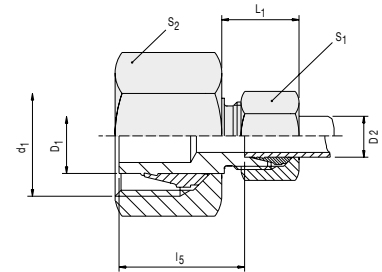

description	pipe OD1	pipe OD2	PN series	L <sub>1</sub>	l <sub>5</sub>	S <sub>1</sub>	S <sub>2</sub>	d <sub>1</sub>	kg / 100 pcs
DS-RS 8/6	8	6	S 800 (3400)	25	25.0	17	19	M 16x1.5	6.5
DS-RS 10/6	10	6		25	26.0	17	22	M 18x1.5	7.0
DS-RS 10/8	10	8		25	26.0	19	22	M 18x1.5	7.5
DS-RS 12/6	12	6		26	27.0	17	24	M 20x1.5	8.0
DS-RS 12/8	12	8		26	27.0	19	24	M 20x1.5	8.5
DS-RS 12/10	12	10		27	26.5	22	24	M 20x1.5	9.9
DS-RS 14/6	14	6		26	29.0	17	27	M 22x1.5	10.4
DS-RS 14/8	14	8		26	29.0	19	27	M 22x1.5	10.9
DS-RS 14/10	14	10		27	28.5	22	27	M 22x1.5	12.1
DS-RS 14/12	14	12		27	28.5	24	27	M 22x1.5	12.6
DS-RS 16/6	16	6	S 630 (2700)	26	29.0	17	30	M 24x1.5	12.1
DS-RS 16/8	16	8		26	29.0	19	30	M 24x1.5	12.6
DS-RS 16/10	16	10		27	28.5	22	30	M 24x1.5	14.0
DS-RS 16/12	16	12		27	28.5	24	30	M 24x1.5	14.5
DS-RS 16/14	16	14		30	30.0	27	30	M 24x1.5	16.1
DS-RS 20/6	20	6		27	34.0	17	36	M 30x2	17.8
DS-RS 20/8	20	8		27	34.0	19	36	M 30x2	18.4
DS-RS 20/10	20	10		28	33.5	22	36	M 30x2	19.5
DS-RS 20/12	20	12		28	33.5	24	36	M 30x2	20.4
DS-RS 20/14	20	14		31	35.0	27	36	M 30x2	22.5
DS-RS 20/16	20	16	31	34.5	30	36	M 30x2	23.9	
DS-RS 25/6	25	6	S 400 (1700)	28	37.0	17	46	M 36x2	31.3
DS-RS 25/8	25	8		28	37.0	19	46	M 36x2	31.9
DS-RS 25/10	25	10		29	36.5	22	46	M 36x2	33.0
DS-RS 25/12	25	12		29	36.5	24	46	M 36x2	33.6
DS-RS 25/14	25	14		31	37.0	27	46	M 36x2	36.0
DS-RS 25/16	25	16		31	36.5	30	46	M 36x2	36.8
DS-RS 25/20	25	20		35	37.5	36	46	M 36x2	40.8
DS-RS 30/6	30	6		27	39.0	17	50	M 42x2	37.7
DS-RS 30/8	30	8		27	39.0	19	50	M 42x2	38.7
DS-RS 30/10	30	10		28	38.5	22	50	M 42x2	39.8
DS-RS 30/12	30	12	28	38.5	24	50	M 42x2	40.4	
DS-RS 30/14	30	14	31	40.0	27	50	M 42x2	42.3	
DS-RS 30/16	30	16	31	39.5	30	50	M 42x2	43.4	
DS-RS 30/20	30	20	35	39.5	36	50	M 42x2	47.6	
DS-RS 30/25	30	25	38	40.0	46	50	M 42x2	59.1	
DS-RS 38/6	38	6	27	43.0	17	60	M 52x2	55.5	
DS-RS 38/8	38	8	27	43.0	19	60	M 52x2	55.7	
DS-RS 38/10	38	10	28	42.5	22	60	M 52x2	57.6	
DS-RS 38/12	38	12	28	42.5	24	60	M 52x2	58.0	
DS-RS 38/14	38	14	31	44.0	27	60	M 52x2	60.0	
DS-RS 38/16	38	16	31	43.5	30	60	M 52x2	61.3	
DS-RS 38/20	38	20	35	43.5	36	60	M 52x2	65.2	
DS-RS 38/25	38	25	38	44.0	46	60	M 52x2	76.9	
DS-RS 38/30	38	30	41	44.5	50	60	M 52x2	80.0	

L<sub>1</sub> = approximate length, with nut tightened

Please see "Engineering and technical data - Selecting the correct tube fitting" for  
- reducing example.

- more information on pressure.

# PIPE CONNECTIONS

REDUCING CONNECTIONS



## RLDKO REDUCING CONNECTION WITH TAPER

With taper and O-ring according to DIN 3865.

Supplied with fitted NBR O-ring (e.g. Perbunan), FKM O-ring (e.g. Viton) upon request.

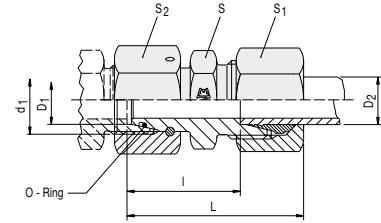

description	pipe OD1	pipe OD2	PN series	L	l	S	S <sub>1</sub>	S <sub>2</sub>	d <sub>1</sub>	O-ring	kg / 100 pcs
DS-RLDKO 8/6	8	6	L 500 (2200)	38.0	23.5	12	14	17	M 14x1.5	6x1.5	3.9
DS-RLDKO 10/6	10	6		39.5	25.0	14	14	19	M 16x1.5	7.5x1.5	4.9
DS-RLDKO 10/8	10	8		39.5	25.0	14	17	19	M 16x1.5	7.5x1.5	5.3
DS-RLDKO 12/6	12	6		39.5	25.0	17	14	22	M 18x1.5	9x1.5	6.3
DS-RLDKO 12/8	12	8		39.5	25.0	17	17	22	M 18x1.5	9x1.5	6.8
DS-RLDKO 12/10	12	10		40.5	26.0	17	19	22	M 18x1.5	9x1.5	7.0
DS-RLDKO 15/6	15	6		43.5	29.0	22	14	27	M 22x1.5	12x2	5.5
DS-RLDKO 15/8	15	8		43.5	29.0	22	17	27	M 22x1.5	12x2	9.8
DS-RLDKO 15/10	15	10		44.0	29.5	22	19	27	M 22x1.5	12x2	10.7
DS-RLDKO 15/12	15	12		44.0	29.5	22	22	27	M 22x1.5	12x2	11.0
DS-RLDKO 18/6	18	6	L 400 (1700)	42.5	28.0	24	14	32	M 26x1.5	15x2	11.9
DS-RLDKO 18/8	18	8		42.5	28.0	24	17	32	M 26x1.5	15x2	12.4
DS-RLDKO 18/10	18	10		43.5	29.0	24	19	32	M 26x1.5	15x2	12.8
DS-RLDKO 18/12	18	12		43.5	29.0	24	22	32	M 26x1.5	15x2	17.2
DS-RLDKO 18/15	18	15		45.0	30.0	24	27	32	M 26x1.5	15x2	19.0
DS-RLDKO 22/6	22	6		46.5	32.0	27	14	36	M 30x2	20x2	16.9
DS-RLDKO 22/8	22	8		46.5	32.0	27	17	36	M 30x2	20x2	17.6
DS-RLDKO 22/10	22	10		47.5	33.0	27	19	36	M 30x2	20x2	17.8
DS-RLDKO 22/12	22	12		47.5	33.0	27	22	36	M 30x2	20x2	18.6
DS-RLDKO 22/15	22	15		49.0	34.0	27	27	36	M 30x2	20x2	20.8
DS-RLDKO 22/18	22	18	49.5	33.5	27	32	36	M 30x2	20x2	24.4	
DS-RLDKO 28/6	28	6	L 250 (1100)	48.5	34.0	36	14	41	M 36x2	26x2	29.3
DS-RLDKO 28/8	28	8		48.5	34.0	36	17	41	M 36x2	26x2	29.3
DS-RLDKO 28/10	28	10		49.5	35.0	36	19	41	M 36x2	26x2	29.9
DS-RLDKO 28/12	28	12		49.5	35.0	36	22	41	M 36x2	26x2	30.8
DS-RLDKO 28/15	28	15		51.0	36.0	36	27	41	M 36x2	26x2	33.0
DS-RLDKO 28/18	28	18		51.5	35.5	36	32	41	M 36x2	26x2	38.3
DS-RLDKO 28/22	28	22		53.5	37.5	36	36	41	M 36x2	26x2	39.1
DS-RLDKO 35/6	35	6		51.5	37.0	46	14	50	M 45x2	32x2.5	33.2
DS-RLDKO 35/8	35	8		51.5	37.0	46	17	50	M 45x2	32x2.5	33.7
DS-RLDKO 35/10	35	10		52.5	38.0	46	19	50	M 45x2	32x2.5	34.2
DS-RLDKO 35/12	35	12	52.5	38.0	46	22	50	M 45x2	32x2.5	35.3	
DS-RLDKO 35/15	35	15	54.0	39.0	46	27	50	M 45x2	32x2.5	37.1	
DS-RLDKO 35/18	35	18	54.5	38.5	46	32	50	M 45x2	32x2.5	39.1	
DS-RLDKO 35/22	35	22	56.5	40.5	46	36	50	M 45x2	32x2.5	41.6	
DS-RLDKO 35/28	35	28	57.0	40.5	46	41	50	M 45x2	32x2.5	42.6	
DS-RLDKO 42/6	42	6	L 250 (1100)	52.0	37.5	50	14	60	M 52x2	38x2.5	51.2
DS-RLDKO 42/8	42	8		52.0	37.5	50	17	60	M 52x2	38x2.5	51.8
DS-RLDKO 42/10	42	10		56.0	41.5	50	19	60	M 52x2	38x2.5	52.3
DS-RLDKO 42/12	42	12		56.0	41.5	50	22	60	M 52x2	38x2.5	53.4
DS-RLDKO 42/15	42	15		57.5	42.5	50	27	60	M 52x2	38x2.5	55.1
DS-RLDKO 42/18	42	18		58.0	42.0	50	32	60	M 52x2	38x2.5	60.7
DS-RLDKO 42/22	42	22		60.0	44.0	50	36	60	M 52x2	38x2.5	66.5
DS-RLDKO 42/28	42	28		60.5	44.0	50	41	60	M 52x2	38x2.5	68.0
DS-RLDKO 42/35	42	35		64.5	43.0	50	50	60	M 52x2	38x2.5	69.5

L = approximate length, with nut tightened

Please see "Engineering and technical data - Selecting the correct tube fitting" for - reducing example.

- more information on pressure.



# PIPE CONNECTIONS

## REDUCING CONNECTIONS



### RSDKO REDUCING CONNECTION WITH TAPER

With taper and O-ring according to DIN 3865.

Supplied with fitted NBR O-ring (e.g. Perbunan), FKM O-ring (e.g. Viton) upon request.

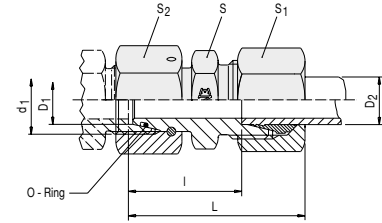

description	pipe OD1	pipe OD2	PN series	L	l	S	S <sub>1</sub>	S <sub>2</sub>	d <sub>1</sub>	O-ring	kg/100 pcs
DS-RSDKO 8/6	8	6	S 800 (3400)	41.5	27.0	14	17	19	M 16x1.5	6x1.5	3.4
DS-RSDKO 10/6	10	6		42.0	27.5	17	17	22	M 18x1.5	7.5x1.5	7.2
DS-RSDKO 10/8	10	8		42.0	27.5	17	19	22	M 18x1.5	7.5x1.5	7.8
DS-RSDKO 12/6	12	6		43.5	29.0	19	17	24	M 20x1.5	9x1.5	8.3
DS-RSDKO 12/8	12	8		43.5	29.0	19	19	24	M 20x1.5	9x1.5	9.3
DS-RSDKO 12/10	12	10		45.5	29.5	19	22	24	M 20x1.5	9x1.5	10.7
DS-RSDKO 14/6	14	6		48.0	33.5	22	17	27	M 22x1.5	10x2	9.2
DS-RSDKO 14/8	14	8		48.0	33.5	22	19	27	M 22x1.5	10x2	9.9
DS-RSDKO 14/10	14	10		49.0	33.0	22	22	27	M 22x1.5	10x2	11.0
DS-RSDKO 14/12	14	12		49.0	33.0	22	24	27	M 22x1.5	10x2	11.9
DS-RSDKO 16/6	16	6	S 630 (2700)	46.5	32.0	22	17	30	M 24x1.5	12x2	12.7
DS-RSDKO 16/8	16	8		46.5	32.0	22	19	30	M 24x1.5	12x2	14.8
DS-RSDKO 16/10	16	10		47.5	31.5	22	22	30	M 24x1.5	12x2	14.8
DS-RSDKO 16/12	16	12		47.5	31.5	22	24	30	M 24x1.5	12x2	15.5
DS-RSDKO 16/14	16	14		50.5	33.0	24	27	30	M 24x1.5	12x2	16.3
DS-RSDKO 20/6	20	6		50.5	36.0	27	17	36	M 30x2	16.3x2.4	18.9
DS-RSDKO 20/8	20	8		50.5	36.0	27	19	36	M 30x2	16.3x2.4	20.5
DS-RSDKO 20/10	20	10		51.5	35.5	27	22	36	M 30x2	16.3x2.4	20.6
DS-RSDKO 20/12	20	12		51.5	35.5	27	24	36	M 30x2	16.3x2.4	21.3
DS-RSDKO 20/14	20	14		54.5	37.0	27	27	36	M 30x2	16.3x2.4	23.2
DS-RSDKO 20/16	20	16	54.5	36.5	27	30	36	M 30x2	16.3x2.4	25.9	
DS-RSDKO 25/6	25	6	S 400 (1700)	53.0	38.5	36	17	46	M 36x2	20.3x2.4	30.8
DS-RSDKO 25/8	25	8		53.0	38.5	36	19	46	M 36x2	20.3x2.4	31.9
DS-RSDKO 25/10	25	10		54.0	38.0	36	22	46	M 36x2	20.3x2.4	33.2
DS-RSDKO 25/12	25	12		54.0	38.0	36	24	46	M 36x2	20.3x2.4	33.4
DS-RSDKO 25/14	25	14		57.0	39.5	36	27	46	M 36x2	20.3x2.4	35.1
DS-RSDKO 25/16	25	16		57.0	39.0	36	30	46	M 36x2	20.3x2.4	37.3
DS-RSDKO 25/20	25	20		60.5	39.0	36	36	46	M 36x2	20.3x2.4	43.6
DS-RSDKO 30/6	30	6		58.5	44.0	41	17	50	M 42x2	25.3x2.4	42.9
DS-RSDKO 30/8	30	8		58.5	44.0	41	19	50	M 42x2	25.3x2.4	43.1
DS-RSDKO 30/10	30	10		59.5	43.5	41	22	50	M 42x2	25.3x2.4	43.6
DS-RSDKO 30/12	30	12	59.5	43.5	41	24	50	M 42x2	25.3x2.4	44.3	
DS-RSDKO 30/14	30	14	62.5	45.0	41	27	50	M 42x2	25.3x2.4	46.1	
DS-RSDKO 30/16	30	16	62.5	44.5	41	30	50	M 42x2	25.3x2.4	48.7	
DS-RSDKO 30/20	30	20	66.0	44.5	41	36	50	M 42x2	25.3x2.4	53.6	
DS-RSDKO 30/25	30	25	69.0	45.0	41	46	50	M 42x2	25.3x2.4	67.3	
DS-RSDKO 38/6	38	6	S 400 (1700)	62.0	47.5	50	17	60	M 52x2	33.3x2.4	70.8
DS-RSDKO 38/8	38	8		62.0	47.5	50	19	60	M 52x2	33.3x2.4	71.0
DS-RSDKO 38/10	38	10		63.0	47.0	50	22	60	M 52x2	33.3x2.4	71.4
DS-RSDKO 38/12	38	12		63.0	47.0	50	24	60	M 52x2	33.3x2.4	72.0
DS-RSDKO 38/14	38	14		66.0	48.5	50	27	60	M 52x2	33.3x2.4	74.3
DS-RSDKO 38/16	38	16		66.0	48.0	50	30	60	M 52x2	33.3x2.4	77.0
DS-RSDKO 38/20	38	20		69.5	48.0	50	36	60	M 52x2	33.3x2.4	81.2
DS-RSDKO 38/25	38	25		72.5	48.5	50	46	60	M 52x2	33.3x2.4	85.0
DS-RSDKO 38/30	38	30		75.5	49.0	50	50	60	M 52x2	33.3x2.4	87.8

L = approximate length. with nut tightened

Please see "Engineering and technical data - Selecting the correct tube fitting" for - reducing example.

- more information on pressure.



**DRIVEN BY POSSIBILITY™**

# **4. VALVES**

# VALVES

NON-RETURN VALVES WITH CONE



## NON-RETURN VALVES – INTRODUCTION

Order code RD

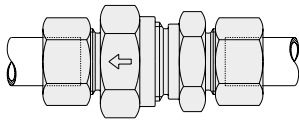

Order code RF

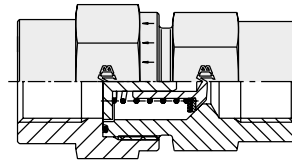

Order code RV

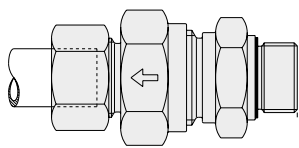

Order code RZ

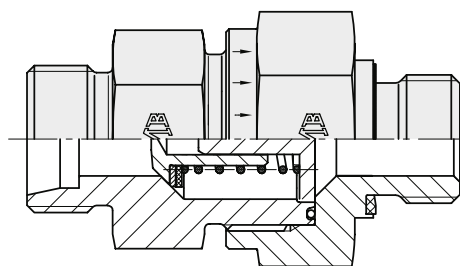
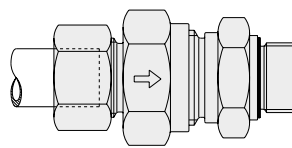

### Sealing

- Guided cone with valve lift stop.
- No diminished cross section.
- Max flow speed is about 8 m/sec.

### Opening pressure

- 1 bar. Further opening pressures upon request.
- Tolerance opening pressure  $\pm 20\%$ .

### Back pressure valves RV and RZ

- Sealing at screwed thread by Gates elastic seal (WD).

### Temperature

- Perbunan standard  $-35^{\circ}\text{C}$  up to  $+100^{\circ}\text{C}$ .
- Viton optional  $-40^{\circ}\text{C}$  up to  $+200^{\circ}\text{C}$ .

### Material

- Drawn steel, galvanised surface.
- Other materials upon request.

# VALVES

NON-RETURN VALVES WITH CONE



## RD NON-RETURN VALVES

Tube connection both ends.

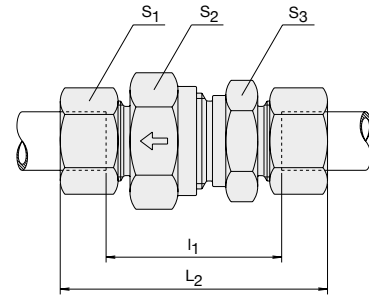

description	pipe OD	PB series	S <sub>1</sub>	S <sub>2</sub>	S <sub>3</sub>	L <sub>1</sub>	l <sub>1</sub>	bore	kg / 100 pcs	
DS-RD 6-L	6	L 250 (625)	14	17	17	58.0	29.0	3.5	6.5	
DS-RD 8-L	8		17	19	19	59.0	30.0	5.5	8.0	
DS-RD 10-L	10		19	24	22	69.5	40.5	7.5	14.0	
DS-RD 12-L	12		22	30	27	72.5	43.5	9.5	21.0	
DS-RD 15-L	15		27	32	27	77.5	47.5	11.5	25.0	
DS-RD 18-L	18	L 160 (400)	32	36	36	83.5	51.5	14.0	40.0	
DS-RD 22-L	22		36	46	41	93.5	61.5	18.0	61.0	
DS-RD 28-L	28		41	55	50	102.5	69.5	23.0	88.0	
DS-RD 35-L	35	L 100 (250)	50	60	60	117.5	74.5	29.0	130.0	
DS-RD 42-L	42		60	70	65	119.0	74.0	29.0	200.0	
DS-RD 6-S	6	S 400 (1000)	17	19	19	63.5	34.5	3.5	9.5	
DS-RD 8-S	8		19	19	19	63.5	34.5	3.5	11.0	
DS-RD 10-S	10		22	24	22	72.5	40.5	5.5	18.0	
DS-RD 12-S	12		24	27	24	74.5	42.5	7.5	21.5	
DS-RD 14-S	14		27	32	27	82.5	47.5	9.5	30.0	
DS-RD 16-S	16		30	36	32	86.5	50.5	11.5	40.0	
DS-RD 20-S	20		36	46	41	97.5	54.5	15.0	69.0	
DS-RD 25-S	25		46	50	46	106.5	58.5	19.0	103.5	
DS-RD 30-S	30		S 250 (625)	50	60	60	122.5	69.5	24.0	159.0
DS-RD 38-S	38			60	70	65	136.5	75.5	29.0	227.0

L<sub>1</sub> = approximate length with nut tightened

Please see "Engineering and technical data - Selecting the correct tube fitting" for more information on pressure

# VALVES

NON-RETURN VALVES WITH CONE



## RV NON-RETURN VALVES BSP

Flow from male stud end.

BSP parallel.

Captive seal O-ring NBR (e.g. Perbunan),  
FKM (e.g. Viton) upon request.

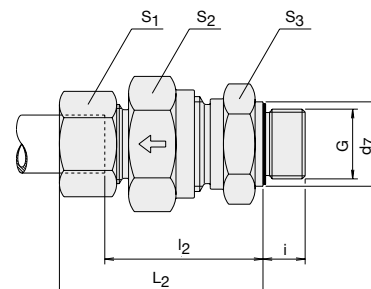

description	pipe OD	PB series	S <sub>1</sub>	S <sub>2</sub>	S <sub>3</sub>	L <sub>2</sub>	l <sub>2</sub>	d <sub>7</sub>	i	bore	G	kg / 100 pcs
DS-RV 6-RL/WD	6	L 250 (625)	14	17	17	42.5	28.0	14	8	3.5	G 1/8" A	5.0
DS-RV 8-RL/WD	8		17	19	19	44.5	30.0	19	12	5.5	G 1/4" A	7.2
DS-RV 10-RL/WD	10		19	24	22	53.0	38.5	19	12	7.5	G 1/4" A	9.0
DS-RV 12-RL/WD	12		22	30	27	57.0	42.5	22	12	9.5	G 3/8" A	18.5
DS-RV 15-RL/WD	15	L 160 (400)	27	32	27	60.5	45.5	27	14	11.5	G 1/2" A	22.5
DS-RV 18-RL/WD	18		32	36	36	66.0	50.0	27	14	14.0	G 1/2" A	33.5
DS-RV 22-RL/WD	22		36	46	41	71.0	55.0	32	16	18.0	G 3/4" A	50.0
DS-RV 28-RL/WD	28	L 100 (250)	41	55	50	79.5	63.0	40	18	23.0	G 1" A	78.5
DS-RV 35-RL/WD	35		50	60	60	90.5	69.0	50	20	29.0	G 1 1/4" A	115.2
DS-RV 42-RL/WD	42		60	70	65	91.0	68.5	55	22	29.0	G 1 1/2" A	179.0
DS-RV 6-RS/WD	6	S 400 (1000)	17	19	19	46.0	31.5	19	12	3.5	G 1/4" A	9.0
DS-RV 8-RS/WD	8		19	19	19	46.0	31.5	19	12	3.5	G 1/4" A	11.5
DS-RV 10-RS/WD	10		22	24	22	54.0	38.0	22	12	5.5	G 3/8" A	15.0
DS-RV 12-RS/WD	12		24	27	24	57.0	41.0	22	12	7.5	G 3/8" A	18.5
DS-RV 14-RS/WD	14		27	32	27	62.0	44.5	27	14	11.5	G 1/2" A	25.5
DS-RV 16-RS/WD	16		30	36	32	66.0	48.0	27	14	11.5	G 1/2" A	32.0
DS-RV 20-RS/WD	20		36	46	41	73.5	52.0	32	16	15.0	G 3/4" A	59.5
DS-RV 25-RS/WD	25	S 250 (625)	46	50	46	78.5	54.5	40	18	19.0	G 1" A	85.0
DS-RV 30-RS/WD	30		50	60	60	90.5	64.0	50	20	24.0	G 1 1/4" A	136.0
DS-RV 38-RS/WD	38		60	70	65	100.0	69.5	55	22	29.0	G 1 1/2" A	195.0

L<sub>2</sub> = approximate length with nut tightened

Please see "Engineering and technical data - Selecting the correct tube fitting" for more information on pressure.

# VALVES

NON-RETURN VALVES WITH CONE



## RV NON-RETURN VALVES METRIC

Flow from male stud end.

Metric parallel.

Captive seal O-ring NBR (e.g. Perbunan),  
FKM (e.g. Viton) upon request.

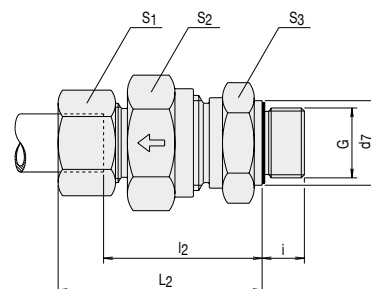

description	pipe OD	PB series	S <sub>1</sub>	S <sub>2</sub>	S <sub>3</sub>	L <sub>2</sub>	l <sub>2</sub>	d <sub>7</sub>	i	bore	G	kg / 100 pcs
DS-RV 6-ML/WD	6	L 250 (625)	14	17	17	42.5	28.0	14	8	3.5	M 10x1	5.0
DS-RV 8-ML/WD	8		17	19	19	43.5	30.0	17	12	5.5	M 12x1.5	7.2
DS-RV 10-ML/WD	10		19	24	22	53.0	38.5	19	12	7.5	M 14x1.5	5.0
DS-RV 12-ML/WD	12		22	30	27	57.0	42.5	22	12	9.5	M 16x1.5	18.5
DS-RV 15-ML/WD	15	L 160 (400)	27	32	27	60.6	45.5	24	12	11.5	M 18x1.5	22.5
DS-RV 18-ML/WD	18		32	36	36	66.0	50.0	27	14	14.0	M 22x1.5	33.5
DS-RV 22-ML/WD	22		36	46	41	71.0	55.0	32	16	18.0	M 26x1.5	50.0
DS-RV 28-ML/WD	28	L 100 (250)	41	55	50	79.5	63.0	40	18	23.0	M 33x2	78.5
DS-RV 35-ML/WD	35		50	60	60	90.5	69.0	50	20	29.0	M 42x2	115.2
DS-RV 42-ML/WD	42	S 400 (1000)	60	70	65	91.0	67.5	55	22	29.0	M 48x2	179.0
DS-RV 6-MS/WD	6		17	19	19	46.0	31.5	17	12	3.5	M 12x1.5	9.0
DS-RV 8-MS/WD	8		19	19	19	46.0	31.5	19	12	3.5	M 14x1.5	11.5
DS-RV 10-MS/WD	10		22	24	22	54.0	38.0	22	12	5.5	M 16x1.5	15.0
DS-RV 12-MS/WD	12		24	27	24	57.0	41.0	24	12	7.5	M 18x1.5	18.5
DS-RV 14-MS/WD	14		27	32	27	62.0	44.5	26	14	9.5	M 20x1.5	25.5
DS-RV 16-MS/WD	16		30	36	32	66.0	48.0	27	14	11.5	M 22x1.5	32.0
DS-RV 20-MS/WD	20		36	46	41	73.5	52.0	32	16	15.0	M 27x2	59.5
DS-RV 25-MS/WD	25	S 250 (625)	46	50	46	78.5	54.5	40	18	19.0	M 33x2	84.5
DS-RV 30-MS/WD	30		50	60	60	90.5	64.0	50	20	24.0	M 42x2	135.0
DS-RV 38-MS/WD	38		60	70	65	100.0	69.5	55	22	29.0	M 48x2	196.8

L<sub>2</sub> = approximate length with nut tightened

Please see "Engineering and technical data - Selecting the correct tube fitting" for more information on pressure.

# VALVES

NON-RETURN VALVES WITH CONE



## RZ NON-RETURN VALVES BSP

Flow towards male stud end.

BSP parallel.

Captive seal O-ring NBR (e.g. Perbunan),  
FKM (e.g. Viton) upon request.

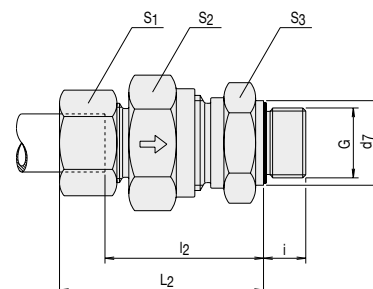

description	pipe OD	PB series	S <sub>1</sub>	S <sub>2</sub>	S <sub>3</sub>	L <sub>2</sub>	l <sub>2</sub>	d <sub>7</sub>	i	bore	G	kg / 100 pcs
DS-RZ 6-RL/WD	6	L 250 (625)	14	17	17	41.0	26.5	14	8	3.5	G 1/8" A	5.1
DS-RZ 8-RL/WD	8		17	19	19	43.0	28.5	19	12	5.5	G 1/4" A	6.5
DS-RZ 10-RL/WD	10		19	24	22	53.0	38.5	19	12	7.5	G 1/4" A	8.5
DS-RZ 12-RL/WD	12		22	27	30	55.0	40.5	22	12	9.5	G 3/8" A	18.0
DS-RZ 15-RL/WD	15	L 160 (400)	27	27	32	57.5	42.5	27	12	11.5	G 1/2" A	21.0
DS-RZ 18-RL/WD	18		32	36	36	64.0	48.0	27	14	14.0	G 1/2" A	32.0
DS-RZ 22-RL/WD	22		36	41	46	72.0	56.0	32	16	18.0	G 3/4" A	49.0
DS-RZ 28-RL/WD	28	L 100 (250)	41	50	55	80.5	64.0	40	18	23.0	G 1" A	77.0
DS-RZ 35-RL/WD	35		50	60	60	91.5	70.0	50	20	29.0	G 1 1/4" A	114.0
DS-RZ 42-RL/WD	42	S 400 (1000)	60	65	70	93.0	70.5	55	22	29.0	G 1 1/2" A	182.0
DS-RZ 6-RS/WD	6		17	19	19	46.0	31.5	19	12	3.5	G 1/4" A	7.5
DS-RZ 8-RS/WD	8		19	19	19	46.0	31.5	19	12	3.5	G 1/4" A	8.5
DS-RZ 10-RS/WD	10		22	22	24	54.0	38.0	22	12	5.5	G 3/8" A	15.0
DS-RZ 12-RS/WD	12		24	24	27	57.0	41.0	22	12	7.5	G 3/8" A	18.0
DS-RZ 14-RS/WD	14		27	27	32	61.0	43.5	27	14	9.5	G 1/2" A	25.2
DS-RZ 16-RS/WD	16		30	32	36	64.0	46.0	27	14	11.5	G 1/2" A	32.5
DS-RZ 20-RS/WD	20		36	41	46	71.5	50.0	32	16	15.0	G 3/4" A	59.0
DS-RZ 25-RS/WD	25	S 250 (625)	46	46	50	78.5	54.5	40	18	19.0	G 1" A	82.5
DS-RZ 30-RS/WD	30		50	60	60	90.5	64.0	50	20	24.0	G 1 1/4" A	133.2
DS-RZ 38-RS/WD	38		60	65	70	102.0	71.5	55	22	29.0	G 1 1/2" A	197.5

L<sub>2</sub> = approximate length with nut tightened

Please see "Engineering and technical data - Selecting the correct tube fitting" for more information on pressure.

# VALVES

NON-RETURN VALVES WITH CONE



## RZ NON-RETURN VALVES METRIC

Flow towards male stud end.

Metric parallel.

Captive seal O-ring NBR (e.g. Perbunan),  
FKM (e.g. Viton) upon request.

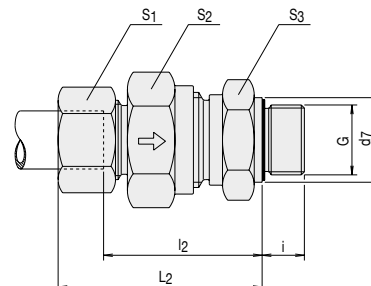

description	pipe OD	PB series	S <sub>1</sub>	S <sub>2</sub>	S <sub>3</sub>	L <sub>2</sub>	l <sub>2</sub>	d <sub>7</sub>	i	bore	G	kg / 100 pcs
DS-RZ 6-ML/WD	6	L 250 (625)	14	17	17	41.0	26.5	14	8	3.5	M 10x1	5.1
DS-RZ 8-ML/WD	8		17	19	19	43.0	28.5	17	12	5.5	M 12x1.5	6.5
DS-RZ 10-ML/WD	10		19	22	24	53.0	38.5	19	12	7.5	M 14x1.5	8.5
DS-RZ 12-ML/WD	12		22	27	30	55.0	40.5	22	12	9.5	M 16x1.5	18.0
DS-RZ 15-ML/WD	15		27	27	32	57.5	42.5	24	12	11.5	M 18x1.5	21.0
DS-RZ 18-ML/WD	18	L 160 (400)	32	36	36	64.0	48.0	27	14	14.0	M 22x1.5	32.0
DS-RZ 22-ML/WD	22		36	41	46	72.0	56.0	32	16	18.0	M 26x1.5	49.0
DS-RZ 28-ML/WD	28		41	50	55	80.5	64.0	40	18	23.0	M 33x2	77.0
DS-RZ 35-ML/WD	35	L 100 (250)	50	60	60	91.5	70.0	50	20	29.0	M 42x2	114.0
DS-RZ 42-ML/WD	42		60	65	70	93.0	70.5	55	22	29.0	M 48x2	180.0
DS-RZ 6-MS/WD	6	S 400 (1000)	17	19	19	46.0	31.5	17	12	3.5	M 12x1.5	7.5
DS-RZ 8-MS/WD	8		19	19	19	46.0	31.5	19	12	3.5	M 14x1.5	8.5
DS-RZ 10-MS/WD	10		22	22	24	54.0	38.0	22	12	5.5	M 16x1.5	15.0
DS-RZ 12-MS/WD	12		24	24	27	57.0	41.0	24	12	7.5	M 18x1.5	18.0
DS-RZ 14-MS/WD	14		27	27	32	61.0	43.5	26	14	9.5	M 20x1.5	25.2
DS-RZ 16-MS/WD	16		30	32	36	64.0	46.0	27	14	11.5	M 22x1.5	32.5
DS-RZ 20-MS/WD	20		36	41	46	71.5	50.0	32	16	15.0	M 27x2	59.0
DS-RZ 25-MS/WD	25		46	46	50	78.5	54.5	40	18	19.0	M 33x2	84.0
DS-RZ 30-MS/WD	30	S 250 (625)	50	60	60	90.5	64.0	50	20	24.0	M 42x2	134.5
DS-RZ 38-MS/WD	38		60	65	70	102.0	71.5	55	22	29.0	M 48x2	199.5

L<sub>2</sub> = approximate length with nut tightened

Please see "Engineering and technical data - Selecting the correct tube fitting" for more information on pressure.



# VALVES

NON-RETURN VALVES WITH CONE



## RF NON-RETURN VALVES

Twin-face inner pipe thread.

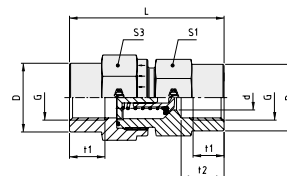

description	PB	S <sub>1</sub>	S <sub>3</sub>	L	t <sub>1</sub> min.	t <sub>2</sub>	D	d	G	kg / 100 pcs
RF 1/8"	400	19	19	42.5	8.0	12.0	19	3.5	G 1/8	7.6
RF 1/4"		19	19	51	12.0	16.0	19	3.5	G 1/4	8.5
RF 3/8"		24	27	60	12.0	17.0	24	7.5	G 3/8	15.6
RF 1/2"		32	36	72	15.0	20.0	32	11.5	G 1/2	34.4
RF 3/4"		41	46	84	16.5	22.0	41	15.0	G 3/4	59.0
RF 1"	250	46	50	95	19.0	25.5	46	19.0	G 1	82.3
RF 1 1/4"		60	60	110	21.5	28.0	60	24.0	G 1 1/4	153.6
RF 1 1/2"		65	70	114	22.0	28.5	65	29.0	G 1 1/2	193.3

Please see "Engineering and technical data - Selecting the correct tube fitting" for more information on pressure.

## RVS INSIDE PARTS NON-RETURN VALVES

Zinc plated steel. Other materials on request.

Perbunan standard -20 °C up to +90 °C.

Viton optional -20 °C up to +120 °C.

Valve lift pressure: Standard 1 bar, alternative valve lift pressure supplied upon request.



Assembly

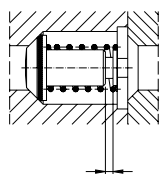

Travel of spring

Bore

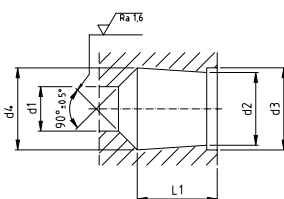

Bore (RVS 6-L/S / 8-S only)  
Bore (must align exactly)

Bore

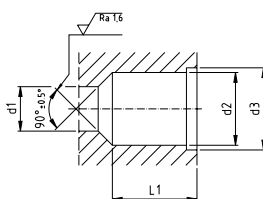

Inside valve parts

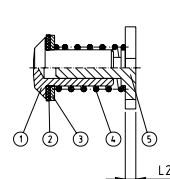

- (1) Bolt
- (2) Seal
- (3) Supporting ring
- (4) Spring
- (5) Cone guide

description	d <sub>1</sub>	d <sub>2</sub> (+0.1)	d <sub>3</sub> (+0.05)	L <sub>1</sub> (± 0.1)	L <sub>2</sub>	deflection	d <sub>4</sub> (+0.2)
X RVS 6-L/S/8-S	4	7.7	8.6	10.3	2.3	2.5	8.5
X RVS 8-L/10-S	6	10.8	11.6	12.7	2.3	2.7	10.75(d2)
X RVS 10-L/12-S	8	13.4	14.1	16.3	2.3	3.3	13.35 (d2)
X RVS 12-L/14-S	10	16.9	18.1	18.9	2.8	3.8	16.9 (d2)
X RVS 15-L/16-S	12	19.5	20.6	21.4	2.8	4.7	19.5 (d2)
X RVS 18-L/20-S	15	25.2	27.1	25.4	3.4	4.7	25.2 (d2)
X RVS 22-L/25-S	19	30.8	32.6	29.6	3.4	5.5	30.8 (d2)
X RVS 28-L/30-S	24	38.7	40.6	34.7	3.8	7.0	38.7 (d2)
X RVS 35-L/38-S	29	45.7	48.1	40.7	3.8	10.0	45.7 (d2)

Please see "Engineering and technical data - Selecting the correct tube fitting" for more information on pressure.



**ARVA BALL CHECK VALVES**

Flow towards male stud end.  
BSP parallel.  
Opening pressure 3 bar.

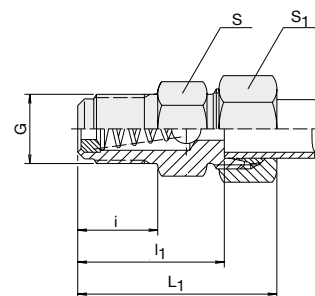

description	pipe OD	PB series	L <sub>1</sub>	l <sub>1</sub>	i	S	S <sub>1</sub>	G
ARVA 4-RLL	4	LL 100	30	21.0	11	11	10	G 1/8" A
ARVA 6-RLL	6		30	19.5	11	11	12	G 1/8" A
ARVA 8-RLL	8		31	20.5	11	12	14	G 1/8" A
DS-ARVA 8-RL	8	L 250	42	27.0	14	17	17	G 1/4" A
DS-ARVA 10-RL	10		41	26.0	14	19	19	G 1/4" A
DS-ARVA 6-RS	6	S 400	44	29.0	14	17	17	G 1/4" A

Please see "Engineering and technical data - Selecting the correct tube fitting" for more information on pressure.

**ARVV BALL CHECK VALVES**

Flow from male stud end.  
BSP parallel.  
Opening pressure 3 bar.  
Pressure difference maximum 125 bar in closing direction.

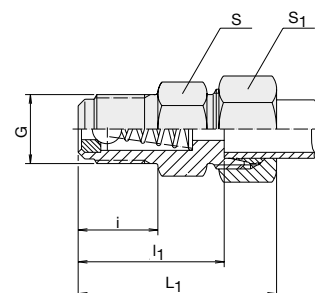

description	pipe OD	PB series	L <sub>1</sub>	l <sub>1</sub>	i	S	S <sub>1</sub>	G
ARVV 4-RLL	4	LL 100	30	21.0	11	11	10	G 1/8" A
ARVV 6-RLL	6		30	19.5	11	11	12	G 1/8" A
ARVV 8-RLL	8		31	20.5	11	12	14	G 1/8" A
DS-ARVV 8-RL	8	L 250	42	27.0	14	17	17	G 1/4" A
DS-ARVV 10-RL	10		41	26.0	14	19	19	G 1/4" A
DS-ARVV 6-RS	6	S 400	44	29.0	14	17	17	G 1/4" A

Please see "Engineering and technical data - Selecting the correct tube fitting" for more information on pressure.



**DRIVEN BY POSSIBILITY™**

# **5. SINGLE PARTS**

# SINGLE PARTS

CUTTING RINGS



## DS CUTTING RING

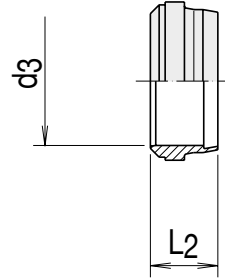

description	pipe OD	L <sub>2</sub>	d <sub>3</sub>
S 4-LL	4	6.0	4
S 6-LL	6	7.0	6
S 8-LL	8	7.0	8
DS 6-L/S	6	9.5	6
DS 8-L/S	8	9.5	8
DS 10-L/S	10	10.0	10
DS 12-L/S	12	10.0	12
DS 15-L	15	10.2	15
DS 18-L	18	10.2	18
DS 22-L	22	11.5	22
DS 28-L	28	11.5	28
DS 35-L	35	13.5	35
DS 42-L	42	13.5	42
DS 6-L/S	6	9.5	6
DS 8-L/S	8	9.5	8
DS 10-L/S	10	10.0	10
DS 12-L/S	12	10.0	12
DS 14-S	14	10.5	14
DS 16-S	16	10.5	16
DS 20-S	20	12.7	20
DS 25-S	25	12.7	25
DS 30-S	30	13.5	30
DS 38-S	38	13.5	38

Please see "Engineering and technical data - Selecting the correct tube fitting" for more information on pressure.

# SINGLE PARTS

CUTTING RINGS



## DSW CUTTING RING

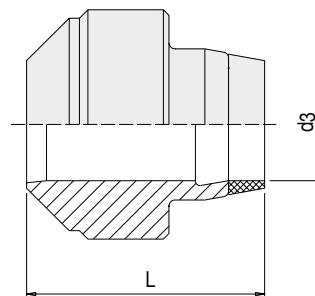

description	pipe OD	PN series	d <sub>3</sub>	L
DSW 6-L/S	6	L 500	6	10.5
DSW 8-L/S	8		8	10.5
DSW 10-L/S	10		10	10.5
DSW 12-L/S	12	L 400	12	10.5
DSW 15-L	15		15	10.5
DSW 18-L	18		18	11.0
DSW 22-L	22	L 250	22	11.7
DSW 28-L	28		28	11.7
DSW 35-L	35		35	14.5
DSW 42-L	42	S 800	42	14.5
DSW 6-L/S	6		6	10.5
DSW 8-L/S	8		8	10.5
DSW 10-L/S	10	S 630	10	10.5
DSW 12-L/S	12		12	10.5
DSW 14-S	14		14	11.0
DSW 16-S	16	S 400	16	11.0
DSW 20-S	20		20	14.0
DSW 25-S	25		25	14.0
DSW 30-S	30	S 400	30	15.0
DSW 38-S	38		38	15.0

Please see "Engineering and technical data - Selecting the correct tube fitting" for more information on pressure.

# SINGLE PARTS

NUTS



## M LOCK NUT

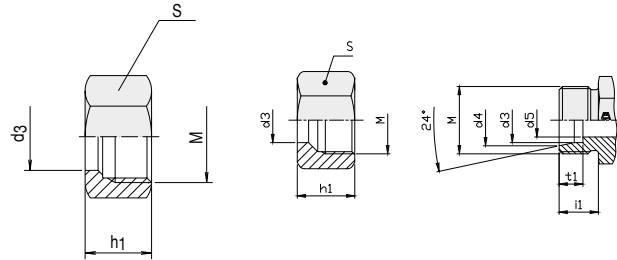

description	pipe OD	M	d <sub>3</sub>	d <sub>4</sub>	d <sub>5</sub>	t <sub>1</sub>	i <sub>1</sub>	S	h <sub>1</sub>
M 4-LL	4	M 8x1	4	5.0	3.0	4.0	8	10	11.5
M 6-LL	6	M 10x1	6	7.5	4.5	5.5	8	12	12.0
M 8-LL	8	M 12x1	8	9.5	6.0	5.5	9	14	12.5
M 6-L	6	M 12x1.5	6	8.1	4.0	7.0	10	14	15.0
M 8-L	8	M 14x1.5	8	10.1	6.0	7.0	10	17	15.0
M 10-L	10	M 16x1.5	10	12.3	8.0	7.0	11	19	16.0
M 12-L	12	M 18x1.5	12	14.3	10.0	7.0	11	22	16.0
M 15-L	15	M 22x1.5	15	17.3	12.0	7.0	12	27	17.5
M 18-L	18	M 26x1.5	18	20.3	15.0	7.5	12	32	18.0
M 22-L	22	M 30x2	22	24.3	19.0	7.5	14	36	20.5
M 28-L	28	M 36x2	28	30.3	24.0	7.5	14	41	22.0
M 35-L	35	M 45x2	35	38.0	30.0	10.5	16	50	25.0
M 42-L	42	M 52x2	42	45.0	36.0	11.0	16	60	25.0
M 6-S	6	M 14x1.5	6	8.1	4.0	7.0	12	17	16.0
M 8-S	8	M 16x1.5	8	10.1	5.0	7.0	12	19	16.0
M 10-S	10	M 18x1.5	10	12.3	7.0	7.5	12	22	17.5
M 12-S	12	M 20x1.5	12	14.3	8.0	7.5	12	24	18.0
M 14-S	14	M 22x1.5	14	16.3	10.0	8.0	14	27	20.0
M 16-S	16	M 24x1.5	16	18.3	12.0	8.5	14	30	21.0
M 20-S	20	M 30x2	20	22.9	16.0	10.5	16	36	24.0
M 25-S	25	M 36x2	25	27.9	20.0	12.0	18	46	26.5
M 30-S	30	M 42x2	30	33.0	25.0	13.5	20	50	29.5
M 38-S	38	M 52x2	38	41.0	32.0	16.0	22	60	32.5

Please see "Engineering and technical data - Selecting the correct tube fitting" for more information on pressure.

# SINGLE PARTS

NUTS



## UES INTERNAL FITTING NUT

Thread: Metric, parallel.

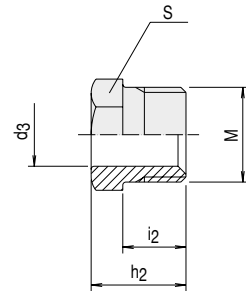

description	pipe OD	PN series	M	d <sub>3</sub>	h <sub>2</sub>	i <sub>2</sub>	S	kg / 100 pcs
UE S 4-LL	4	LL 100	M 8x1	4	12	8.0	8	0.2
UE S 6-LL	6		M 10x1	6	13	9.0	10	0.4
UE S 8-LL	8		M 12x1	8	14	9.5	12	0.6
UE S 6-L	6	L 500	M 12x1.5	6	16	11.5	12	0.9
UE S 8-L	8		M 14x1.5	8	16	11.5	14	1.1
UE S 10-L	10		M 16x1.5	10	17	11.5	17	1.5
UE S 12-L	12	L 400	M 18x1.5	12	18	12.0	19	1.9

Please see "Engineering and technical data - Selecting the correct tube fitting" for more information on pressure.

## GM COUNTER NUT

For bulkhead connections.

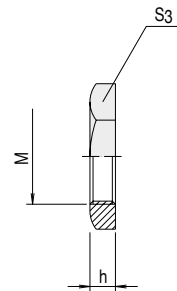

description	M	S <sub>3</sub>	h	kg / 100 pcs
GM 6-L	M 12x1.5	17	6	0.7
GM 6-S/ 8-L	M 14x1.5	19	6	0.8
GM 8-S/10-L	M 16x1.5	22	6	1.1
GM 10-S/12-L	M 18x1.5	24	6	1.2
GM 12-S	M 20x1.5	27	6	1.5
GM 14-S/15-L	M 22x1.5	30	7	2.2
GM 16-S	M 24x1.5	32	7	2.4
GM 18-L	M 26x1.5	36	8	3.7
GM 20-S/22-L	M 30x2	41	8	4.6
GM 25-S/28-L	M 36x2	46	9	6.0
GM 30-S	M 42x2	50	9	5.8
GM 35-L	M 45x2	55	9	7.5
GM 38-S/42-L	M 52x2	65	10	12.3

Please see "Engineering and technical data - Selecting the correct tube fitting" for more information on pressure.

# SINGLE PARTS

PLUGS



## VSCH BLANKING PLUG

With internal hexagon and captive seal NBR (e.g. Perbunan).

Thread: BSP parallel, metric parallel.

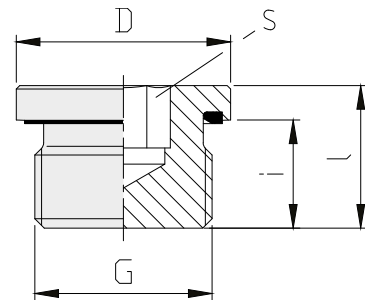

description	PN	G	D	I	i	S	MA*/NM
VSCH-M10x1/WD	400	M 10x1	14	12.0	8	5	10
VSCH-M 12x1.5/WD		M 12x1.5	17	17.0	12	6	20
VSCH-M 14x1.5/WD		M 14x1.5	19	17.0	12	6	30
VSCH-M 16x1.5/WD		M 16x1.5	22	17.0	12	8	40
VSCH-M 18x1.5/WD		M 18x1.5	24	17.0	12	8	50
VSCH-M 20x1.5/WD		M 20x1.5	26	19.0	14	10	60
VSCH-M 22x1.5/WD		M 22x1.5	27	19.0	14	10	80
VSCH-M 26x1.5/WD		M 26x1.5	32	21.0	16	12	100
VSCH-M 27x2/WD		M 27x2	32	21.0	16	12	120
VSCH-M 33x2/WD		M 33x2	40	22.5	16	17	200
VSCH-M 42x2/WD	315	M 42x2	50	22.5	16	22	350
VSCH-M 48x2/WD		M 48x2	55	22.5	16	24	400
VSCH-R 1/8"/WD	400	G 1/8" A	14	12.0	8	5	10
VSCH-R 1/4"/WD		G 1/4" A	19	17.0	12	6	30
VSCH-R 3/8"/WD		G 3/8" A	22	17.0	12	8	40
VSCH-R 1/2"/WD		G 1/2" A	27	19.0	14	10	80
VSCH-R 3/4"/WD		G 3/4" A	32	21.0	16	12	120
VSCH-R 1"/WD		G 1" A	40	22.5	16	17	200
VSCH-R 1 1/4"/WD	315	G 1 1/4" A	50	22.5	16	22	350
VSCH-R 1 1/2"/WD		G 1 1/2" A	55	22.5	16	24	400

\* MA = tightening torques relate to steel counterparts

Please see "Engineering and technical data - Selecting the correct tube fitting" for more information on  
 - internal screw threads.  
 - pressure.



# SINGLE PARTS

PLUGS



## VSCHK STANDPIPE END PLUG

With 24° inner cone.

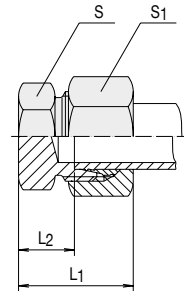

description	pipe OD	PN series	S	S <sub>1</sub>	L <sub>1</sub>	L <sub>2</sub>
DS-VSCHK 6-L	6		12	14	22	7.0
DS-VSCHK 8-L	8	L 500 (2200)	14	17	23	8.0
DS-VSCHK 10-L	10		17	19	24	9.0
DS-VSCHK 12-L	12		19	22	25	10.0
DS-VSCHK 15-L	15	L 400 (1700)	24	27	26	11.0
DS-VSCHK 18-L	18		27	32	28	11.5
DS-VSCHK 22-L	22		32	36	30	13.5
DS-VSCHK 28-L	28	L 250 (1100)	41	41	31	14.5
DS-VSCHK 35-L	35		46	50	36	14.5
DS-VSCHK 42-L	42		55	60	39	16.0
DS-VSCHK 6-S	6		14	17	26	11.0
DS-VSCHK 8-S	8	S 800 (3400)	17	19	28	13.0
DS-VSCHK 10-S	10		19	22	29	12.5
DS-VSCHK 12-S	12		22	24	31	14.5
DS-VSCHK 14-S	14	S 630 (2700)	24	27	34	16.0
DS-VSCHK 16-S	16		27	30	34	15.5
DS-VSCHK 20-S	20		32	36	39	17.5
DS-VSCHK 25-S	25	S 400 (1700)	41	46	44	20.0
DS-VSCHK 30-S	30		46	50	47	20.5
DS-VSCHK 38-S	38		55	60	54	23.0

L<sub>1</sub> = approximate length with tightened nut

Please see "Engineering and technical data - Selecting the correct tube fitting" for more information on  
- internal screw threads.

- pressure.

# SINGLE PARTS

PLUGS



## STO/O BLANKING PLUG

For cones with taper and O-ring according to DIN 3865.

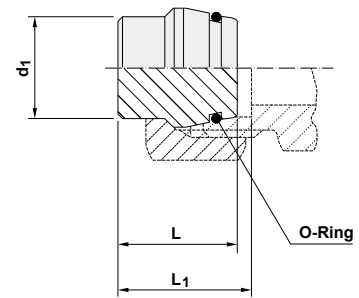

description	pipe OD	PN series	L	L <sub>1</sub>	O-Ring	kg / 100 pcs
STO 6-L/S/O	6	L 500 (2200)	18.5	20.0	4x1.5	0.6
STO 8-L/S/O	8		18.5	20.0	6x1.5	0.9
STO 10-L/S/O	10		20.0	21.0	7.5x1.5	1.4
STO 12-L/S/O	12	L 400 (1700)	20.5	21.5	9x1.5	1.9
STO 15-L/O	15		20.5	21.5	12x2	3.1
STO 18-L/O	18		22.5	24.0	15x2	6.2
STO 22-L/O	22	L 250 (1100)	25.0	26.5	20x2	9.9
STO 28-L/O	28		25.5	27.0	26x2	15.1
STO 35-L/O	35		30.0	33.0	32x2.5	25.2
STO 42-L/O	42	S 800 (3400)	30.0	33.5	38x2.5	35.9
STO 6-L/S/O	6		18.5	20.0	4x1.5	0.6
STO 8-L/S/O	8		18.5	20.0	6x1.5	0.9
STO 10-L/S/O	10	S 630 (2700)	20.0	21.5	7.5x1.5	1.4
STO 12-L/S/O	12		20.5	22.0	9x1.5	1.9
STO 14-S/O	14		22.5	24.5	10x2	2.6
STO 16-S/O	16	S 400 (1700)	23.5	26.0	12x2	4.6
STO 20-S/O	20		28.5	31.5	16.3x2.4	7.7
STO 25-S/O	25		29.0	32.5	20.3x2.4	11.9
STO 30-S/O	30	S 400 (1700)	30.5	35.5	25.3x2.4	17.9
STO 38-S/O	38		33.0	40.5	33.4x2.4	30.8

Please see "Engineering and technical data - Selecting the correct tube fitting" for more information on pressure.

# SINGLE PARTS

SEALING RINGS



## DKA/DKAD SEAL EDGE RING

For banjo fittings and swiveling screw-fittings  
SBE, SGE, SB, and SBD.

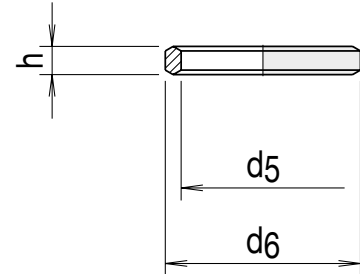

description	use SBE../SGE..	h	kg / 100 pcs	G	d <sub>5</sub>	d <sub>6</sub>
DKA R 1/8"/SA 2.5	6-RL	2.5	0.1	G 1/8" A	10.0	14
DKA R 1/4"/SA 3	8-RL; 6-RS	3.0	0.2	G 1/4" A	13.2	18
DKA R 3/8"/SA 3	12-RL; 10-RS	3.0	0.3	G 3/8" A	16.7	22
DKA R 1/2"/SA 4.5	15-RL; 14-RS	4.5	0.6	G 1/2" A	21.0	26
DKAD R 3/4"	22-RL; 20-RS	3.5	0.6	G 3/4" A	26.4	32
DKA R 1"/M33/SA3.5	28-RL; 25-RS	3.5	0.9	G 1" A	33.3	39
DKA R 1 1/4"/M42/SA3.5	35-RL; 30-RS	3.5	1.2	G 1 1/4" A	42.0	49
DKA R 1 1/2"/M48/SA3.5	42-RL; 38-RS	3.5	1.4	G 1 1/2" A	48.0	55
DKA M10/SA2.5	6-ML	2.5	0.1	M 10x1	10.0	14
DKA M12/SA3	8-ML; 6-MS	3.0	0.2	M 12x1.5	12.0	17
DKA M14/SA3	10-ML; 8-MS	3.0	0.3	M 14x1.5	14.0	19
DKA M16/SA3	12-ML; 10-MS	3.0	0.3	M 16x1.5	16.0	21
DKA M18/SA3	15-ML; 12-MS	3.0	0.3	M 18x1.5	18.0	23
DKA M20/SA3	14-MS	3.0	0.4	M 20x1.5	20.0	25
DKA M22	18-ML; 16-MS	4.5	0.6	M 22x1.5	22.0	27
DKAD M26	22-ML	3.5	0.5	M 26x1.5	26.0	31
DKAD M27	20-MS	3.5	0.6	M 27x2	27.0	32
DKA R 1"/M33/SA3.5	28-ML; 25-MS	3.5	0.8	M 33x2	33.3	39
DKA R 1 1/4"/M42/SA3.5	35-ML; 30-MS	3.5	1.2	M 42x2	42.0	49
DKA R 1 1/2"/M48/SA3.5	42-ML; 38-MS	3.5	1.4	M 48x2	48.0	55

Please see "Engineering and technical data - Selecting the correct tube fitting" for more information on pressure.

# SINGLE PARTS

SEALING RINGS



## DKA/DKAD SEAL EDGE RING

For banjo fittings and swiveling screw-fittings  
SBE, SGE, SB, and SBD.

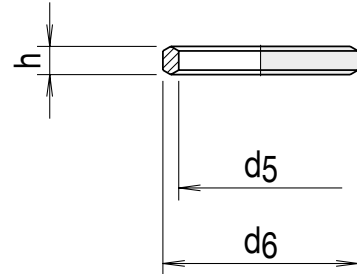

description	use SB../	h	kg / 100 pcs	G	d <sub>5</sub>	d <sub>6</sub>
DKA R 1/8"/M10	6-RL	3.7	0.2	G 1/8" A	10.0	14
DKA R 1/4"	8-RL; 6-RS	4.5	0.3	G 1/4" A	13.2	18
DKA R 3/8"	12-RL; 10-RS	4.5	0.4	G 3/8" A	16.7	22
DKA R 1/2"	15-RL; 14-RS	5.5	0.7	G 1/2" A	21.0	26
DKA R 3/4"	22-RL; 20-RS	5.0	0.7	G 3/4" A	26.4	32
DKA R 1"/M33	28-RL; 25-RS	6.0	1.1	G 1" A	33.3	39
DKA R 1 1/4"/M42	35-RL; 30-RS	6.5	1.3	G 1 1/4" A	42.0	49
DKA R 1 1/2"/M48	42-RL; 38-RS	6.5	1.5	G 1 1/2" A	48.0	55
DKA R 1/8"/M10	6-ML	3.7	0.2	M 10x1	10.0	14
DKA M12	8-ML; 6-MS	4.5	0.3	M 12x1.5	12.0	17
DKA M14	10-ML; 8-MS	4.5	0.4	M 14x1.5	14.0	19
DKA M16	12-ML; 10-MS	4.5	0.4	M 16x1.5	16.0	21
DKA M18	15-ML; 12-MS	4.5	0.4	M 18x1.5	18.0	23
DKA M20	14-MS	4.5	0.5	M 20x1.5	20.0	25
DKA M22	18-ML; 16-MS	4.5	0.6	M 22x1.5	22.0	27
DKA M26	22-ML	4.5	0.6	M 26x1.5	26.0	31
DKA M27	20-MS	5.5	0.7	M 27x2	27.0	32
DKA R 1"/M33	28-ML; 25-MS	6.0	1.0	M 33x2	33.3	39
DKA R 1 1/4"/M42	35-ML; 30-MS	6.5	1.3	M 42x2	42.0	49
DKA R 1 1/2"/M48	42-ML; 38-MS	6.5	1.5	M 48x2	48.0	55

Please see "Engineering and technical data - Selecting the correct tube fitting" for more information on pressure.

description	use SB../	h	kg / 100 pcs	G	d <sub>5</sub>	d <sub>6</sub>
DKAD R 1/2"	18-RL	3.5	0.5	G 1/2" A	21.0	26
DKAD R 3/4"	22-RL	3.5	0.6	G 3/4" A	26.5	32
DKAD R 1/2"	16-RS	3.5	0.5	G 1/2" A	21.0	26
DKAD R 3/4"	20-RS	3.5	0.6	G 3/4" A	26.5	32
DKAD M 22	18-ML	3.5	0.5	M 22 x 1.5	22.0	27
DKAD M 26	22-ML	3.5	0.6	M 26 x 1.5	26.0	31
DKAD M 22	16-MS	3.5	0.5	M 22 x 1.5	22.0	27
DKAD M 27	20-MS	3.5	0.6	M 27 x 2	27.0	32

Please see "Engineering and technical data - Selecting the correct tube fitting" for more information on pressure.

# SINGLE PARTS

SEALING RINGS



## DKI SEAL EDGE RING

Packing rings for pressure gauge screw connection.

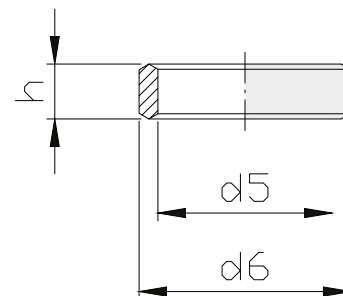

description	for internal thread	d <sub>5</sub>	d <sub>6</sub>	h
DKI R 1/4"	G 1/4"	6	11.3	4.5
DKI R 1/2"	G 1/2"	12	18.5	5.0

Please see "Engineering and technical data - Selecting the correct tube fitting" for more information on pressure.

## WD CAPTIVE SEAL

For stud threads DIN 3852-11.

Materials WD: NBR (e.g. Perbunan), and FKM (e.g. Viton).

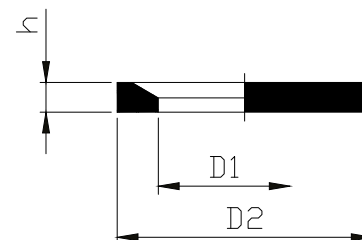

description	stud thread	mm DIN 3869	D <sub>1</sub>	D <sub>2</sub>	h
WD M 8 x 1 / ...	M 8 x 1	8	6.5	9.9	1.0
WD R 1/8" / M 10 x 1 / ...	M 10 x 1 / G 1/8" A	10	8.4	11.9	1.0
WD M 12 x 1.5 / ...	M 12 x 1.5	12	9.8	14.4	1.5
WD R 1/4" / M 14 x 1.5 / ...	M 14 x 1.5 / G 1/4" A	14	11.6	16.5	1.5
WD M 16 x 1.5 / ...	M 16 x 1.5	16	13.8	18.9	1.5
WD R 3/8" / ...	G 3/8" A	17	14.7	18.9	1.5
WD M 18 x 1.5 / ...	M 18 x 1.5	18	15.7	20.9	1.5
WD M 20 x 1.5 / ...	M 20 x 1.5	20	17.8	22.9	1.5
WD R 1/2" / ...	G 1/2" A	21	18.5	23.9	1.5
WD M 22 x 1.5 / ...	M 22 x 1.5	22	19.6	24.3	1.5
WD R 3/4" / M 26 / M 27 / ...	M 26 x 1.5 / M 27 x 2 / G 3/4" A	27	23.9	29.2	1.5
WD R 1" / M 33 x 2 / ...	M 33 x 2 / G 1" A	33	29.7	35.7	2.0
WD R 1 1/4" / M 42 x 2 / ...	M 42 x 2 / G 1 1/4" A	42	38.8	45.8	2.0
WD R 1 1/2" / M 48 x 2 / ...	M 48 x 2 / G 1 1/2" A	48	44.7	50.7	2.0

Please see "Engineering and technical data - Selecting the correct tube fitting" for more information on pressure.

# SINGLE PARTS

SEALING RINGS



## TR SEALING RING

For DSW-rings.

Materials WD: NBR (e.g. Perbunan),  
and FKM (e.g. Viton).

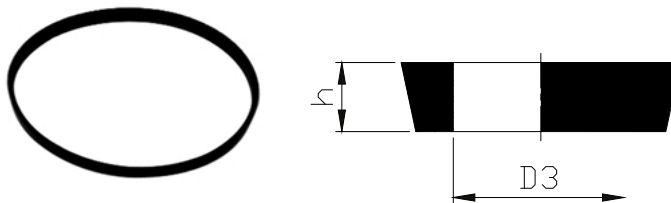

description	h	D <sub>3</sub>
TR 6-L/S	1.5	5.7
TR 8-L/S	1.5	7.7
TR 10-L/S	1.5	9.7
TR 12-L/S	1.5	11.7
TR 15-L	1.5	14.7
TR 18-L	1.5	17.7
TR 22-L	1.2	21.7
TR 28-L	1.2	27.7
TR 35-L	2.0	34.6
TR 42-L	2.0	41.6
TR 6-L/S	1.5	5.7
TR 8-L/S	1.5	7.7
TR 10-L/S	1.5	9.7
TR 12-L/S	1.5	11.7
TR 14-S	1.5	13.7
TR 16-S	1.5	15.7
TR 20-S	2.0	19.7
TR 25-S	2.0	24.7
TR 30-S	2.0	29.6
TR 38-S	2.0	37.6

Please see "Engineering and technical data - Selecting the correct tube fitting" for more information on pressure.

# SINGLE PARTS

SEALING RINGS



## KDE RETAINING RING

For banjo fittings SBE.

Matches counter bore according to DIN 3852.

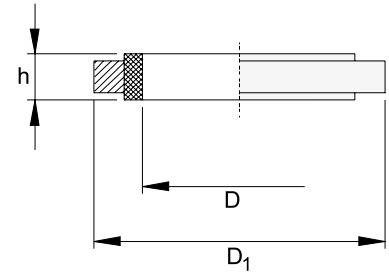

description	use SBE...	D <sub>1</sub>	D	h
KDE R 1/8" / M10	6-RL	17	10.2	2.5
KDE R 1/4"	6-RS; 8-RL/-RS; 10-RL	22	13.3	3.0
KDE R 3/8"	10-RS; 12-RL/-RS	27	16.8	3.0
KDE R 1/2"	14-RS; 15-RL; 16-RS; 18-RL	32	21.1	4.5
KDE R 3/4" / M26 / M27	20-RS/-MS; 22-RL	41	27.3	3.5
KDE R 1" / M33	25-RS/-MS; 28-RL/-ML	46	33.4	3.5
KDE R 1 1/4" / M42	30-RS/-MS; 35-RL/-ML	57	42.4	3.5
KDE R 1 1/2" / M48	38-RS/-RL; 42-RL/-ML	64	48.4	3.5
KDE M12	6-MS; 8-ML	22	12.2	3.0
KDE M14	8-MS; 10-ML	23	14.3	3.0
KDE M16	10-MS; 12-ML	27	16.3	3.0
KDE M18	12-MS; 15-ML	29	18.3	3.0
KDE M20	14-MS	32	20.3	3.0
KDE M22	16-MS; 18-ML	32	22.3	4.5

Please see "Engineering and technical data - Selecting the correct tube fitting" for more information on pressure.

# SINGLE PARTS

SEALING RINGS



## EDE RETAINING RING

With captive seal (NBR) for banjo fittings SBE/SGE.

Matches „narrow” counter bore according to DIN 3852.

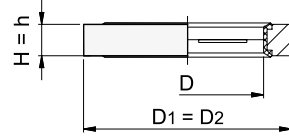
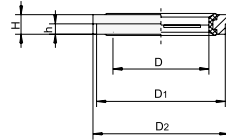

description	use SBE../SGE..	Version	male thread	D	D <sub>1</sub>	D <sub>2</sub>	H	h	kg / 100 pcs
EDE R 1/8" - M 10	6-ML/RL	1	M 10 x 1 / G 1/8" A	10.1	14.9	16.0	2.5	1.1	0.2
EDE M 12	6-MS/8-ML	1	M 12 x 1.5	12.1	16.9	18.0	3.0	1.6	0.5
EDE R 1/4" - M 14	6-RS	1	M 14 x1.5 / G 1/4" A	14.1	18.9	20.0	3.0	1.6	0.4
EDE R 1/4" - M 14	8-RL/MS/RS	1	M 14 x1.5 / G 1/4" A	14.1	18.9	20.0	3.0	1.6	0.4
EDE R 1/4" - M 14	10-ML/RL	1	M 14 x1.5 / G 1/4" A	14.1	18.9	20.0	3.0	1.6	0.4
EDE R 3/8" - M 16	10-MS/RS	1	M 16 x 1.5 / G 3/8" A	16.7	21.9	24.0	3.0	2.1	0.6
EDE R 3/8" - M 16	12-ML/RL/RS	1	M 16 x 1.5 / G 3/8" A	16.7	21.9	24.0	3.0	2.1	0.6
EDE M 18	12-MS/15-ML	2	M 18 x 1.5	18.1	23.9	23.9	3.0	-	0.7
EDE R 1/2" - M 22	14-RS/15-RL	1	M 22 x 1.5 / G 1/2" A	22.1	26.9	30.0	4.5	2.6	1.2
EDE R 1/2" - M 22	16-MS/RS	1	M 22 x 1.5 / G 1/2" A	22.1	26.9	30.0	4.5	2.6	1.2
EDE R 1/2" - M 22	18-ML/RL	1	M 22 x 1.5 / G 1/2" A	22.1	26.9	30.0	4.5	2.6	1.2
EDE M 26	22-ML	1	M 26 x 1.5	26.1	31.9	35.0	3.5	2.6	1.8
EDE R 3/4" - M 27	20-MS/RS	1	M 27 x 2 / G 3/4" A	27.1	32.9	38.0	3.5	2.6	1.7
EDE R 3/4" - M 27	22-RL	1	M 27 x 2 / G 3/4" A	27.1	32.9	38.0	3.5	2.6	1.7
EDE R 1" - M 33	25-MS/RS	1	M 33 x 2 / G 1" A	33.3	39.9	42.0	3.5	2.6	1.7
EDE R 1" - M 33	28-ML/RL	1	M 33 x 2 / G 1" A	33.3	39.9	42.0	3.5	2.6	1.7
EDE R 1 1/4" - M 42	30-MS/RS	2	M 42 x 2 / G 1 1/4" A	42.2	49.9	49.9	3.5	-	2.6
EDE R 1 1/4" - M 42	35-ML/RL	2	M 42 x 2 / G 1 1/4" A	42.2	49.9	49.9	3.5	-	2.6
EDE R 1 1/2" - M 48	38-MS/RS	1	M 48 x 2 / G 1 1/2" A	48.2	55.9	60.0	3.5	2.6	3.2
EDE R 1 1/2" - M 48	42-ML/RL	1	M 48 x 2 / G 1 1/2" A	48.2	55.9	60.0	3.5	2.6	3.2

Version 1: with countersink

Version 2: without countersink  $D_1=D_2$

Please see "Engineering and technical data - Selecting the correct tube fitting" for more information on pressure.



# SINGLE PARTS

VSH SUPPORT SLEEVES



## VSH SUPPORT SLEEVE

For safe assembly of fittings on plastic, non-ferrous metal and thin-walled steel tubes.

Available in stainless steel (1.4571) as well.

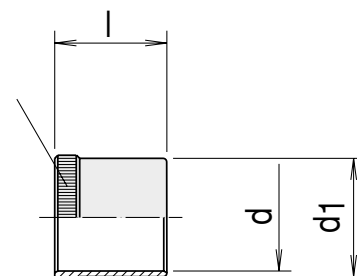

description	Tube OD x wall thickness	Tube int. $\varnothing$	l	d	d <sub>1</sub>
VSH 6x1	6x1	4.0	14.0	2.6	3.8
VSH 6x0.75	6x0.75	4.5	14.0	3.1	4.3
VSH 6x0.5	6x0.5	5.0	14.0	3.6	4.8
VSH 8x1	8x1	6.0	14.0	4.6	5.8
VSH 8x0.5/10x1.5	8x0.5/10x1.5	7.0	14.0	5.6	6.8
VSH 10x1	10x1	8.0	14.0	6.6	7.8
VSH 12x1.5	12x1.5	9.0	16.0	7.6	8.8
VSH 12x1	12x1	10.0	16.0	8.6	9.8
VSH 14x1/15x1.5	14x1/15x1.5	12.0	18.0	10.6	11.8
VSH 15x1/16x1.5	15x1/16x1.5	13.0	18.0	11.6	12.8
VSH 16x1/18x2	16x1/18x2	14.0	20.0	12.2	13.8
VSH 18x1.5	18x1.5	15.0	20.0	13.2	14.8
VSH 18x1/20x2	18x1/20x2	16.0	20.0	14.2	15.8
VSH 20x1.5	20x1.5	17.0	20.0	15.2	16.8
VSH 20x1/22x2	20x1/22x2	18.0	20.0	16.2	17.8
VSH 22x1.5	22x1.5	19.0	20.0	17.2	18.8
VSH 22x1/25x2.5	22x1/25x2.5	20.0	20.0	18.2	19.8
VSH 25x2	25x2	21.0	20.0	19.2	20.8
VSH 25x1.5	25x1.5	22.0	20.0	20.2	21.8
VSH 28x2	28x2	24.0	20.0	22.2	23.8
VSH 28x1.5	28x1.5	25.0	20.0	23.2	24.8
VSH 28x1/30x2	28x1/30x2	26.0	25.5	24.2	25.8
VSH 35x2.5	35x2.5	30.0	22.5	27.8	29.8
VSH 35x2	35x2	31.0	22.5	28.8	30.8
VSH 35x1.5	35x1.5	32.0	22.5	29.8	31.8
VSH 38x2.5	38x2.5	33.0	22.5	30.8	32.8
VSH 42x2	42x2	38.0	23.5	35.8	37.8

Please see "Engineering and technical data - Selecting the correct tube fitting" for  
 - the table on the application of reinforcing sleeves.  
 - more information on pressure.



**DRIVEN BY POSSIBILITY™**

# **6. WELDING NIPPLE-PIPE SCREW JOINTS**

# WELDING NIPPLE-PIPE SCREW JOINTS

WELDING NIPPLES



## SNO WELDING NIPPLE WITH O-RING SEAL

NBR O-ring (e.g. Perbunan) supplied separately, to be fitted after welding.

FKM O-ring (e.g. Viton) supplied on request.

Special dimensions and materials upon request.

Welding end without tube centre.

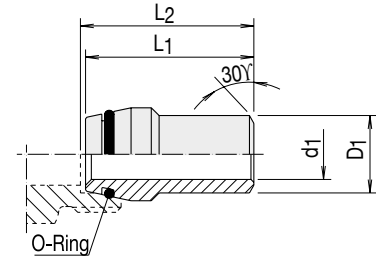

description	pipe dimension	PN-V*	PB**	d <sub>1</sub>	L <sub>1</sub>	L <sub>2</sub>	O-Ring	kg / 100 pcs
SNO 15x1.5	15x1.5	400	160	12.0	33.5	33.5	12x2	2.3
SNO 15x2	15x2	400	160	11.0	33.5	33.5	12x2	2.7
SNO 18x2	18x2	400	100	14.0	35.0	33.5	15x2	3.2
SNO 18x2.75	18x2.75	400	160	12.5	35.0	33.5	15x2	4.4
SNO 22x2	22x2	250	100	18.0	37.5	33.5	20x2	4.0
SNO 22x2.5	22x2.5	250	100	17.0	37.5	33.5	20x2	5.0
SNO 22x3	22x3	250	160	16.0	37.5	40.5	20x2	5.6
SNO 28x2.5	28x2.5	250	100	23.0	40.5	40.5	26x2	7.4
SNO 28x3	28x3	250	100	22.0	40.5	40.5	26x2	8.2
SNO 35x3	35x3	250	100	29.0	46.0	40.5	32x2	12.0
SNO 42x3	42x3	250	100	36.0	46.0	47.0	38x2	14.7
SNO 42x4	42x4	250	100	34.0	46.0	47.0	38x2	18.6

\* Rated Pressure (PN) for the equivalent fitting. L-series      \*\* Maximum operating pressure (PB) for SNO and tube  
Please see "Engineering and technical data - Selecting the correct tube fitting" for more information on pressure.

description	pipe dimension	PN-V*	PB**	d <sub>1</sub>	L <sub>1</sub>	L <sub>2</sub>	O-Ring	kg / 100 pcs
SNO 10x1	10x1	800	249	8	31.5	33.5	7.5x1.5	1.0
SNO 10x1.5	10x1.5	800	358	7	31.5	33.5	7.5x1.5	1.3
SNO 10x2	10x2	800	460	6	31.5	33.5	7.5x1.5	1.5
SNO 12x1.5	12x1.5	630	305	9	31.5	33.5	9x1.5	1.5
SNO 12x2	12x2	630	391	8	31.5	33.5	9x1.5	1.9
SNO 12x2.5	12x2.5	630	474	7	31.5	33.5	9x1.5	2.2
SNO 16x1.5	16x1.5	630	234	13	37.5	40.5	12x2	2.7
SNO 16x2	16x2	630	303	12	37.5	40.5	12x2	3.1
SNO 16x2.5	16x2.5	630	370	11	37.5	40.5	12x2	3.6
SNO 16x3	16x3	630	433	10	37.5	40.5	12x2	4.1
SNO 20x2	20x2	400	249	16	43.5	47.0	16.3x2.4	5.4
SNO 20x2.5	20x2.5	400	305	15	43.5	47.0	16.3x2.4	5.7
SNO 20x3	20x3	400	357	14	43.5	47.0	16.3x2.4	6.2
SNO 20x4	20x4	400	458	12	43.5	47.0	16.3x2.4	7.8
SNO 25x3	25x3	400	292	19	49.5	53.5	20.3x2.4	8.9
SNO 25x4	25x4	400	378	17	49.5	53.5	20.3x2.4	11.1
SNO 25x5	25x5	400	458	15	49.5	53.5	20.3x2.4	12.5
SNO 30x3	30x3	400	249	24	52.0	57.5	25.3x2.4	13.5
SNO 30x4	30x4	400	321	22	52.0	57.5	25.3x2.4	14.0
SNO 30x5	30x5	400	391	20	52.0	57.5	25.3x2.4	16.6
SNO 30x6	30x6	400	460	18	52.0	57.5	25.3x2.4	17.1
SNO 38x4	38x4	400	260	30	56.5	64.5	33.3x2.4	19.5
SNO 38x5	38x5	400	318	28	56.5	64.5	33.3x2.4	23.6
SNO 38x6	38x6	400	373	26	56.5	64.5	33.3x2.4	27.0
SNO 38x7	38x7	400	428	24	56.5	64.5	33.3x2.4	28.6

\* Rated Pressure (PN) for the equivalent fitting. S-series      \*\* Maximum operating pressure (PB) for SNO and tube  
Please see "Engineering and technical data - Selecting the correct tube fitting" for more information on pressure.

# WELDING NIPPLE-PIPE SCREW JOINTS

WELDING NIPPLES



## SNR WELDING NIPPLE REDUCER

NBR O-ring (e.g. Perbunan) supplied separately, to be fitted after welding.

FKM O-ring (e.g. Viton) supplied on request.

Special dimensions and materials upon request.

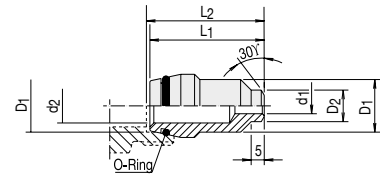

description	D1	D2	PN-V*	PB**	d <sub>1</sub>	d <sub>2</sub>	L <sub>1</sub>	L <sub>2</sub>	O-Ring	kg / 100 pcs
SNR 10/6x2	10	6	800	638	2	4	31.5	33.5	7.5x1.5	1.5
SNR 10/8x2.5	10	8		630	3	4	31.5	33.5	7.5x1.5	1.7
SNR 12/8x2.5	12	8		630	624	3	5	31.5	33.5	9 x1.5
SNR 12/10x3	12	10	624		4	5	31.5	33.5	9 x1.5	1.8
SNR 16/12x3.5	16	12	400	433	5	10	37.5	40.5	12 x2	4.3
SNR 20/12x3.5	20	12		458	5	12	43.5	47.0	16.3x2.4	8.0
SNR 20/16x3	20	16		433	10	12	43.5	47.0	16.3x2.4	7.8
SNR 25/16x3	25	16		433	10	15	49.5	53.5	20.3x2.4	12.3
SNR 25/20x4	25	20		458	12	15	49.5	53.5	20.3x2.4	12.4
SNR 30/16x3	30	16		433	10	18	52.0	57.5	25.3x2.4	16.5
SNR 30/20x4	30	20		458	12	18	52.0	57.5	25.3x2.4	15.9
SNR 30/25x5	30	25		458	15	18	52.0	57.5	25.3x2.4	14.4
SNR 38/16x3	38	16		433	10	22	56.5	64.5	33.3x2.4	27.9
SNR 38/20x4	38	20		458	12	22	56.5	64.5	33.3x2.4	27.8
SNR 38/25x5	38	25	458	15	22	56.5	64.5	33.3x2.4	26.2	
SNR 38/30x4	38	30	321	22	22	56.5	64.5	33.3x2.4	25.2	

\* Rated Pressure (PN) for the equivalent fitting. S-series

\*\* Maximum operating pressure (PB) for SNO and tube

Please see "Engineering and technical data - Selecting the correct tube fitting" for more information on pressure.

# WELDING NIPPLE-PIPE SCREW JOINTS

WELDING TYPE SCREW JOINTS



## SNO-V WELDING TYPE SCREW JOINT

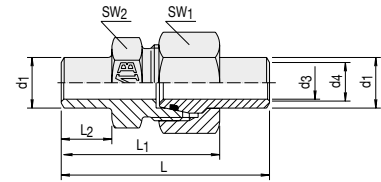
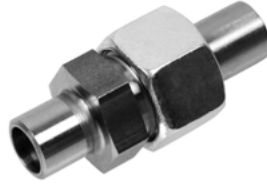

description	PB*	d <sub>1</sub>	d <sub>4</sub>	d <sub>3</sub>	SW <sub>2</sub>	SW <sub>1</sub>	L	L <sub>1</sub>	L <sub>2</sub>	kg / 100 pcs
SNO-V-10x1-S/SA	249	10	7	8	19	22	60.0	43.0	14	5.6
SNO-V-10x1.5-S/SA	358	10	7	7	19	22	60.0	43.0	14	7.3
SNO-V-10x2-S/SA	460	10	7	6	19	22	60.0	43.0	14	8.5
SNO-V-12x1.5-S/SA	305	12	8	9	22	24	62.0	45.5	14	7.4
SNO-V-12x2-S/SA	391	12	8	10	22	24	62.0	45.5	14	9.3
SNO-V-12x2.5-S/SA	474	12	8	7	22	24	62.0	45.5	14	10.8
SNO-V-16x1.5-S/SA	234	16	12	13	27	30	71.0	49.0	14	12.4
SNO-V-16x2-S/SA	303	16	12	12	27	30	71.0	49.0	14	14.3
SNO-V-16x2.5-S/SA	370	16	12	11	27	30	71.0	49.0	14	16.6
SNO-V-16x3-S/SA	433	16	12	10	27	30	71.0	49.0	14	19.1
SNO-V-20x2-S/SA	249	20	15	16	32	36	84.5	60.5	20	22.7
SNO-V-20x2.5-S/SA	305	20	15	15	32	36	84.5	60.5	20	23.9
SNO-V-20x3-S/SA	357	20	15	14	32	36	84.5	60.5	20	26.1
SNO-V-20x4-S/SA	400	20	15	12	32	36	84.5	60.5	20	32.3
SNO-V-25x3-S/SA	292	25	20	19	41	46	93.5	65.5	20	41.8
SNO-V-25x4-S/SA	378	25	20	17	41	46	93.5	65.5	20	55.5
SNO-V-25x5-S/SA	400	25	20	15	41	46	93.5	65.5	20	58.5
SNO-V-30x3-S/SA	249	30	25	24	46	50	98.0	68.5	20	59.4
SNO-V-30x4-S/SA	321	30	25	22	46	50	98.0	68.5	20	68.5
SNO-V-30x5-S/SA	391	30	25	20	46	50	98.0	68.5	20	73.3
SNO-V-30x6-S/SA	400	30	25	18	46	50	98.0	68.5	20	75.3
SNO-V-38x4-S/SA	260	38	32	30	55	60	107.5	75.0	20	82.0
SNO-V-38x5-S/SA	318	38	32	28	55	60	107.5	75.0	20	104.5
SNO-V-38x6-S/SA	373	38	32	26	55	60	107.5	75.0	20	111.0
SNO-V-38x7-S/SA	400	38	32	24	55	60	107.5	75.0	20	120.1

\* Maximum operating pressure (PB) for SNO and tube

Please see "Engineering and technical data - Selecting the correct tube fitting" for more information on pressure.

# WELDING NIPPLE-PIPE SCREW JOINTS

WELDING TYPE SCREW JOINTS



## SNO-A ORDER EXAMPLE SCREW JOINT

### SNO-A 25X3-RS/WD

SNO	Code for welding nipple (steel nipple O-ring)
A	Type of fitting
25	Outside pipe diameter
3	Wall thickness of welding nipple
R	Stud thread
S	Series
WD	Soft seal
xxx	Additional code



### SNO-A 25X3-RS/WD/VIT/1.4571

SNO	Code for welding nipple (steel nipple O-ring)
A	Type of fitting
25	Outside pipe diameter
3	Wall thickness of welding nipple
R	Stud thread
S	Series
WD	Soft seal
VIT	Code Viton
1.4517	Code stainless steel



**DRIVEN BY POSSIBILITY™**

# **7. FLARE FITTINGS**

# FLARE FITTINGS

ABO FLARE CONNECTION PARTS

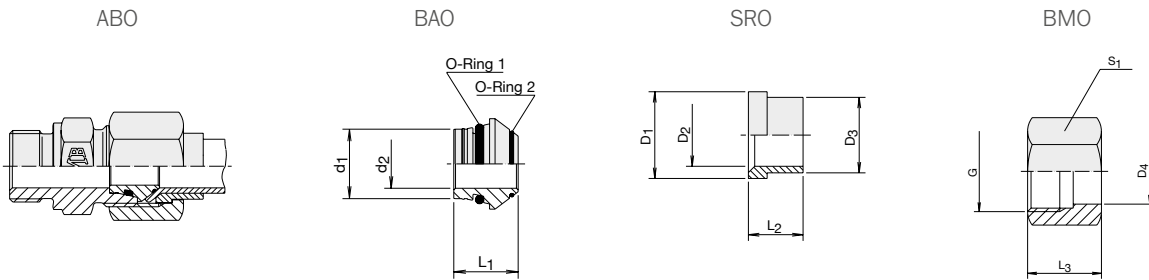

## FLARE CONNECTION PARTS

BAO supplied with NBR O-rings (e.g. Perbunan).  
FKM O-rings (e.g. Viton) upon request.

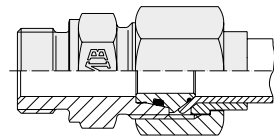

description	flare adaptor	support ring	nut
ABO 6-L	BAO 6-L/S	SRO 6-L/S	BM0-6L
ABO 8-L	BAO 8-L/S	SRO 8-L/S	BM0-8L
ABO 10-L	BAO 10-L/S	SRO 10-L/S	BM0-10L
ABO 12-L	BAO 12-L/S	SRO 12-L/S	BM0-12L
ABO 15-L	BAO 15-L	SRO 15-L	BM0-15L
ABO 18-L	BAO 18-L	SRO 18-L	BM0-18L
ABO 22-L	BAO 22-L	SRO 22-L	BM0-22L
ABO 28-L	BAO 28-L	SRO 28-L	BM0-28L
ABO 35-L	BAO 35-L	SRO 35-L	BM0-35L
ABO 42-L	BAO 42-L	SRO 42-L	BM0-42L
ABO 6-S	BAO 6-L/S	SRO 6-L/S	BM0-6S
ABO 8-S	BAO 8-L/S	SRO 8-L/S	BM0-8S
ABO 10-S	BAO 10-L/S	SRO 10-L/S	BM0-10S
ABO 12-S	BAO 12-L/S	SRO 12-L/S	BM0-12S
ABO 14-S	BAO 14-S	SRO 14-S	BM0-14S
ABO 16-S	BAO 16-S	SRO 16-S	BM0-16S
ABO 20-S	BAO 20-S	SRO 20-S	BM0-20S
ABO 25-S	BAO 25-S	SRO 25-S	BM0-25S
ABO 30-S	BAO 30-S	SRO 30-S	BM0-30S
ABO 38-S	BAO 38-S	SRO 38-S	BM0-38S

Please see "Engineering and technical data – Selecting the correct tube fitting" for functional characteristics, tube length determination and assembly instructions.



# FLARE FITTINGS

ABO FLARE CONNECTION PARTS



description	PN series	Tube OD	d <sub>1</sub>	d <sub>2</sub>	L <sub>1</sub>	O-Ring 1	O-Ring 2
BAO 6-L/S	L500	6	6	3	11.5	4x1.5	4.4x0.8
BAO 8-L/S		8	8	5	12.0	6x1.5	6x0.8
BAO 10-L/S		10	10	6	12.5	7.5x1.5	7.5x0.8
BAO 12-L/S	L400	12	12	8	12.5	9x1.5	9.5x0.8
BAO 15-L		15	15	11	12.5	12x2	12.5x0.8
BAO 18-L		18	18	14	13.0	15x2	15x1
BAO 22-L	L250	22	22	17	14.2	20x2	18x1
BAO 28-L		28	28	23	14.7	26x2	23x1
BAO 35-L		35	35	28	18.5	32x2.5	30x1
BAO 42-L		42	42	35	20.5	38x2.5	36.5x1
BAO 6-L/S	S630	6	6	3	11.5	4x1.5	4.4x0.8
BAO 8-L/S		8	8	5	12.0	6x1.5	6x0.8
BAO 10-L/S		10	10	6	12.5	7.5x1.5	7.5x0.8
BAO 12-L/S		12	12	8	12.5	9x1.5	9.5x0.8
BAO 14-S		14	14	9	14.0	10x2	11x1
BAO 16-S		16	16	11	15.0	12x2	12.5x1
BAO 20-S	S400	20	20	14	18.5	16.3x2.4	16x1
BAO 25-S		25	25	19	20.0	20.3x2.4	20x1
BAO 30-S		30	30	23	22.0	25.3x2.4	25x1
BAO 38-S		38	38	30	26.0	33.3x2.4	31.47x1.78

description	PN series	Tube OD	D <sub>1</sub>	D <sub>2</sub>	D <sub>3</sub>	L <sub>2</sub>	description	thread	D <sub>4</sub>	L <sub>3</sub>	S <sub>1</sub>
SRO 6-L/S	L500	6	10.2	6	7.6	10.5	BMO-6L	12x1.5	7.8	17.0	14
SRO 8-L/S		8	12.2	8	9.3	11.0	BMO-8L	14x1.5	9.5	18.0	17
SRO 10-L/S		10	14.2	10	11.5	12.5	BMO-10L	16x1.5	11.7	19.5	19
SRO 12-L/S	L400	12	16.2	12	13.6	13.0	BMO-12L	18x1.5	13.8	20.5	22
SRO 15-L		15	20.2	15	17.5	14.0	BMO-15L	22x1.5	17.7	23.0	27
SRO 18-L		18	24.2	18	21.0	14.5	BMO-18L	26x1.5	21.2	23.0	32
SRO 22-L	L250	22	27.8	22	24.2	18.0	BMO-22L	30x2	24.4	27.5	36
SRO 28-L		28	33.8	28	30.2	17.0	BMO-28L	36x2	30.4	27.5	41
SRO 35-L		35	42.7	35	38.0	19.0	BMO-35L	45x2	38.3	30.0	50
SRO 42-L		42	49.7	42	45.0	21.0	BMO-42L	52x2	45.3	34.0	60
SRO 6-L/S	S630	6	10.2	6	7.6	10.5	BMO-6S	14x1.5	7.8	18.0	17
SRO 8-L/S		8	12.2	8	9.3	11.0	BMO-8S	16x1.5	9.5	19.0	19
SRO 10-L/S		10	14.2	10	11.5	12.5	BMO-10S	18x1.5	11.7	20.5	22
SRO 12-L/S		12	16.2	12	13.6	13.0	BMO-12S	20x1.5	13.8	21.0	24
SRO 14-S		14	20.2	14	17.5	14.5	BMO-14S	22x1.5	17.7	23.0	27
SRO 16-S		16	22.0	16	18.5	17.0	BMO-16S	24x1.5	18.7	26.5	30
SRO 20-S	S400	20	27.8	20	24.2	17.5	BMO-20S	30x2	24.4	27.5	36
SRO 25-S		25	32.8	25	28.5	20.0	BMO-25S	36x2	28.7	30.5	46
SRO 30-S		30	39.0	30	34.0	21.5	BMO-30S	42x2	34.2	32.0	50
SRO 38-S		38	48.5	38	42.0	26.5	BMO-38S	52x2	42.3	38.0	60

Please see "Engineering and technical data – Selecting the correct tube fitting" for functional characteristics, tube length determination and assembly instructions.

# FLARE FITTINGS

ABO FLARE CONNECTION PARTS

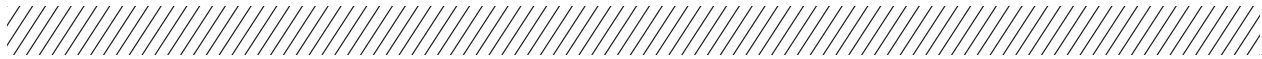

## ABO-A ORDER EXAMPLE SCREW JOINT

If ordering complete fittings with flare connection parts, add the letters ABO to the normal Order No.



### ABO-A 20-RS

- ABO Code for flare fitting
- A Type of fitting
- 20 Outside pipe diameter
- R Stud thread
- S Series

### ABO -A 20-RS/VIT/1.4571

- ABO Code for flare fitting
- A Type of fitting
- 20 Outside pipe diameter
- R Stud thread
- S Series
- VIT Code Viton
- 1.4517 Code stainless steel

Please see "Engineering and technical data – Selecting the correct tube fitting" for functional characteristics, tube length determination and assembly instructions.



**DRIVEN BY POSSIBILITY™**

# **8. CONTROL SYSTEM**

# CONTROL SYSTEM

CST CONNECT TEST SYSTEM WITH PIN LOCK 400 BAR



## CST SYSTEM INTRODUCTION

### CST application

- Fast fitting for monitoring and control of pressure.
- Venting and sampling in high, low and vacuum systems up to 400 bar.

### CST advantages

- Fitting at system pressure level.
- Leak proof connection before ball valve is open.
- Simple connection with measuring, control and switching devices.

### CST materials

- Metal parts: Steel, Stainless Steel on request.
- Ball: Stainless Steel.
- Seals (add the letter to the description):
  - P = Buna N (Temperature range -20 °C to +100 °C).
  - VIT = Viton (Temperature range -20 °C to +200 °C).
  - E = Ethylene Propylene on request (for brake fluid).
- Hose: Polyamide (+100 °C maximum).

Data in this catalogue is according to technical standard current at the time of printing and is subject to change without notification.

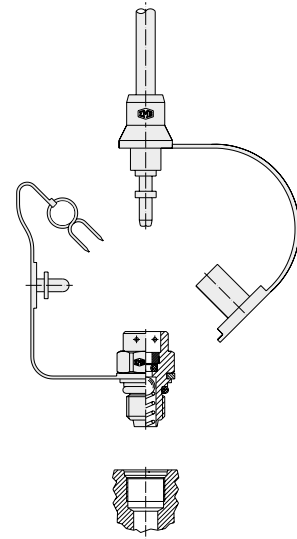

# CONTROL SYSTEM

CST CONNECT TEST SYSTEM WITH PIN LOCK 400 BAR



## CST CONNECT TEST SYSTEM WITH PIN LOCK

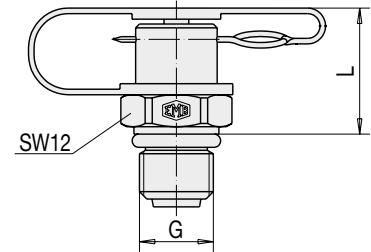

description	PN	G	L	Seal
CST M 8 x 1	250	M 8 x 1	18	O-Ring
CST M 10 x 1	400	M 10 x 1	18	O-Ring
CST R 1/8" K		R 1/8"	18	Taper Form D

Please see "Engineering and technical data - Selecting the correct tube fitting" for more information on port connections and seals.

## CST PRESSURE GAUGE FITTING WITH PIN LOCK

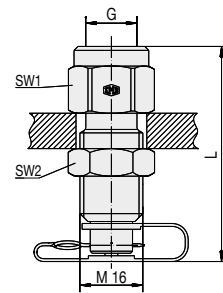

description	G	L	SW1	SW2
CSTO-G 1/4"	G 1/4"	66	19	19
CSTO-G 1/2"	G 1/2"	75	27	24
CSTO-1/4 NPT	1/4 NPT	68	19	19
CSTO-1/2 NPT	1/2 NPT	75	27	24

Please see "Engineering and technical data - Selecting the correct tube fitting" for more information on port connections and seals.

# CONTROL SYSTEM

CST CONNECT TEST SYSTEM WITH PIN LOCK 400 BAR



## CST TEST FITTING FOR CUTTING RING CONNECTION E

Test fitting with straight connection.

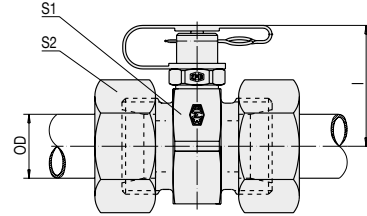

description	PN series	pipe OD	l	SW1	SW2
DS-CSTE 6-L	L 315	6	29.0	22	14
DS-CSTE 8-L		8	30.0	24	17
DS-CSTE 10-L		10	30.0	24	19
DS-CSTE 12-L		12	32.0	27	22
DS-CSTE 15-L		15	33.0	30	27
DS-CSTE 18-L		18	34.0	32	32
DS-CSTE 22-L	L 160	22	36.0	36	36
DS-CSTE 28-L		28	39.0	41	41
DS-CSTE 35-L		35	41.0	46	50
DS-CSTE 42-L		42	46.0	55	60
DS-CSTE 6-S	S 630	6	30.0	24	17
DS-CSTE 8-S		8	30.0	24	19
DS-CSTE 10-S		10	30.0	24	22
DS-CSTE 12-S		12	30.0	24	24
DS-CSTE 14-S	S 400	14	32.0	27	27
DS-CSTE 16-S		16	33.0	30	30
DS-CSTE 20-S		20	34.0	32	36
DS-CSTE 25-S		25	38.5	41	46
DS-CSTE 30-S	S 315	30	41.0	46	50
DS-CSTE 38-S		38	46.0	55	60

# CONTROL SYSTEM

CST CONNECT TEST SYSTEM WITH PIN LOCK 400 BAR



## CST TEST FITTING FOR CUTTING RING CONNECTION S

Test fitting with taper and O-ring.

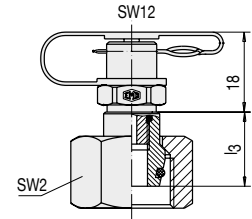
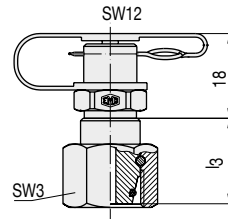

description	PN series	pipe OD	l <sub>3</sub>	SW2/3
CSTS 6-L	L 315	6	33.0	14
CSTS 8-L		8	33.0	17
CSTS 10-L		10	33.0	19
CSTS 12-L		12	33.0	22
CSTS 15-L		15	20.0	27
CSTS 18-L		18	22.0	32
CSTS 22-L		22	22.0	36
CSTS 28-L	L 160	28	24.0	41
CSTS 35-L		35	27.0	50
CSTS 42-L		42	28.0	60
CSTS 6-S	S 630	6	34.0	17
CSTS 8-S		8	34.0	19
CSTS 10-S		10	34.0	22
CSTS 12-S		12	34.0	24
CSTS 14-S		14	20.0	27
CSTS 16-S	S 400	16	20.0	30
CSTS 20-S		20	25.0	36
CSTS 25-S		25	27.0	46
CSTS 30-S		30	29.0	50
CSTS 38-S		S 315	38	32.0

# CONTROL SYSTEM

CSH TEST FITTINGS WITH SCREW LOCK 630 BAR

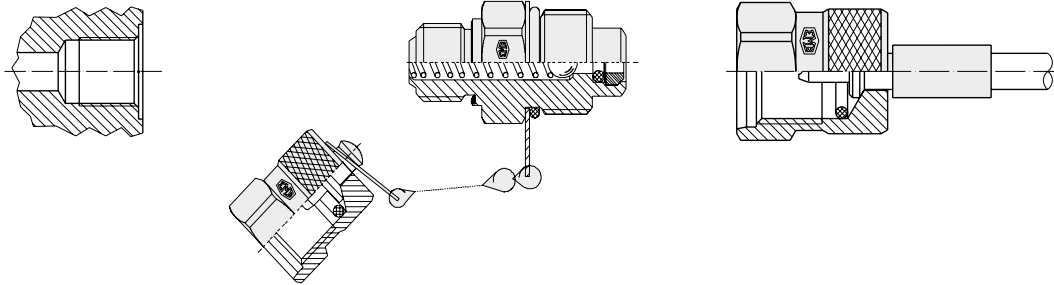

## CSH SYSTEM INTRODUCTION

### CSH application

- Monitoring and control of pressure.
- Venting and sampling in high, low and vacuum systems up to 630 bar working pressure.
- Connecting under pressure up to 400 bar.

### CSH advantages

- Fitting at system pressure level.
- Leak proof connection before ball valve is open.
- Simple connection with measuring, control and switching devices.
- Self-locking metal guard cap.

### CSH materials

- Metal parts: Steel, Stainless Steel on request.
- Ball: Stainless Steel.
- Seals (add the letter to the description):
  - P = Buna N (Temperature range -20 °C to +100 °C).
  - VIT = Viton (Temperature range -20 °C to +200 °C).
  - E = Ethylene Propylene on request (for brake fluid).
- Data in this catalogue is according to technical standard current at the time of printing and is subject to change without notification.

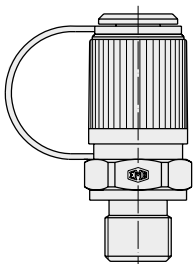

The complete CSH range is available with hexagonal plastic caps



# CONTROL SYSTEM

CSH TEST FITTINGS WITH SCREW LOCK 630 BAR



## CSH TEST FITTING WITH SCREW LOCK

Type series M16x2.

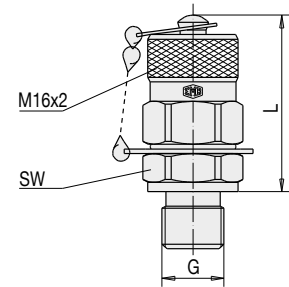

description	G	L	SW	sealing
CSH M 8 x 1	M 8 x 1	38	17	O-Ring Form A
CSH M 10 x 1	M 10 x 1	38	17	O-Ring Form A
CSH M 12 x 1.5/WD	M 12 x 1.5	39	17	WD Form C
CSH M 14 x 1.5	M 14 x 1.5	37	19	Metaljoint Form B
CSH M 16 x 1.5	M 16 x 1.5	37	22	Metaljoint Form B
CSH R 1/8"	G 1/8"	38	17	Metaljoint Form B
CSH R 1/8"/WD	G 1/8"	39	17	WD Form C
CSH R 1/8" K	R 1/8" K	36	17	Taper Form D
CSH R 1/4"	G 1/4"	37	19	Metaljoint Form B
CSH R 1/4"/WD	G 1/4"	37	19	WD Form C
CSH R 1/4" K	R 1/4" K	35	17	Taper Form D
CSH R 3/8"	G 3/8"	37	22	Metaljoint Form B
CSH R 3/8"/WD	G 3/8"	37	22	WD Form C
CSH 1/8" NPT	1/8" NPT	36	17	Taper Form D
CSH 1/4" NPT	1/4" NPT	35	17	Taper Form D
CSH 5/16" UNF	5/16"-24 UNF	38	17	O-Ring Form E
CSH 1/2" UNF	1/2"-20 UNF	38	17	O-Ring Form E
CSH 7/16" UNF	7/16"-20 UNF	38	17	O-Ring Form E
CSH 9/16" UNF	9/16"-18 UNF	38	19	O-Ring Form E

Please see "Engineering and technical data - Selecting the correct tube fitting" for more information on port connections and seals.

# CONTROL SYSTEM

CSH TEST FITTINGS WITH SCREW LOCK 630 BAR

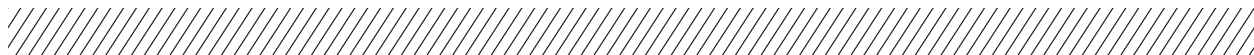

## CSH TEST FITTING FOR CUTTING RING CONNECTION E

Test fitting with straight connection.

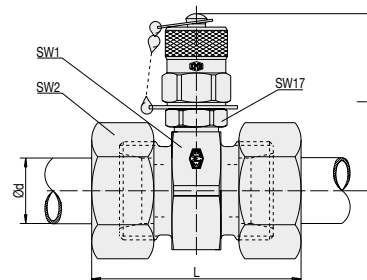

description	PN series	pipe OD	l	SW1	SW2
DS-CSHE 6-L	L 315	6	48.0	22	14
DS-CSHE 8-L		8	49.0	24	17
DS-CSHE 10-L		10	49.0	24	19
DS-CSHE 12-L		12	51.0	27	22
DS-CSHE 15-L		15	53.0	30	27
DS-CSHE 18-L		18	53.0	32	32
DS-CSHE 22-L	L 160	22	55.0	36	36
DS-CSHE 28-L		28	58.0	41	41
DS-CSHE 35-L		35	60.0	46	50
DS-CSHE 42-L		42	65.0	55	60
DS-CSHE 6-S	S 630	6	49.0	24	17
DS-CSHE 8-S		8	49.0	24	19
DS-CSHE 10-S		10	49.0	24	22
DS-CSHE 12-S		12	49.0	24	24
DS-CSHE 14-S	S 400	14	51.0	27	27
DS-CSHE 16-S		16	52.0	30	30
DS-CSHE 20-S		20	53.0	32	36
DS-CSHE 25-S		25	58.0	41	46
DS-CSHE 30-S	S 315	30	60.0	46	50
DS-CSHE 38-S		38	65.0	55	60

# CONTROL SYSTEM

CSH TEST FITTINGS WITH SCREW LOCK 630 BAR



## CSH TEST FITTING FOR CUTTING RING CONNECTION S

Test fitting with taper and O-ring.

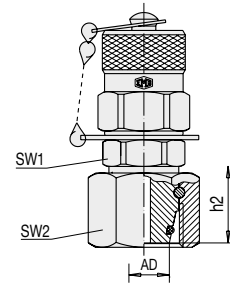

description	PN series	pipe OD	h <sub>1</sub>	h <sub>2</sub>	SW1	SW2
CSHS 6-L	L 315	6	53		14	17
CSHS 8-L		8	53		17	17
CSHS 10-L		10	50		19	17
CSHS 12-L		12	50		22	17
CSHS 15-L		15	51		27	19
CSHS 18-L		18		22	32	
CSHS 22-L	L 160	22		22	36	
CSHS 28-L		28		24	41	
CSHS 35-L		35		27	50	
CSHS 42-L		42		28	60	
CSHS 6-S	S 630	6	54		17	17
CSHS 8-S		8	51		19	17
CSHS 10-S		10	51		22	17
CSHS 12-S		12	51		24	17
CSHS 14-S		14	53		27	19
CSHS 16-S	S 400	16		20	30	
CSHS 20-S		20		25	36	
CSHS 25-S		25		27	46	
CSHS 30-S		30		29	50	
CSHS 38-S	S 315	38		32	60	

# CONTROL SYSTEM

CSH TEST FITTINGS WITH SCREW LOCK 630 BAR



## CSH DIRECT GAUGE ADAPTOR

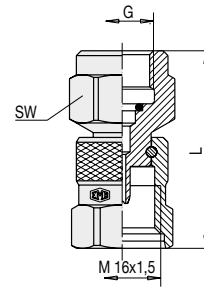

description	G	L	SW
CSHD-G 1/4	G 1/4	54	19
CSHD-G 1/2	G 1/2	58	27
CSHD-1/4 NPT	1/4 NPT	53	19
CSHD-1/2 NPT	1/2 NPT	59	27

## CSH GAUGE ADAPTOR

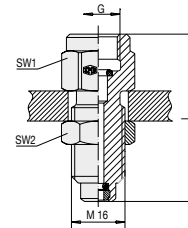

description	G	L	SW1	SW2
CSHO-R 1/4"	R 1/4	57	19	19
CSHO-R 1/2"	R 1/2	66	27	24

# CONTROL SYSTEM

CSH TEST FITTINGS WITH SCREW LOCK 630 BAR



## CSH REDUCING FITTING

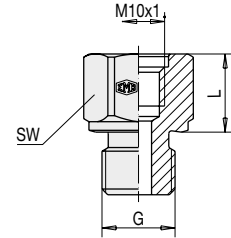

description	G	L	SW	sealing
CSH-RS-M 16 x 1.5	M 16 x 1.5	18	22	Metaljoint Form B
CSH-RS-G 1/8	G 1/8	19	14	Metaljoint Form B
CSH-RS-G 3/8	G 3/8	18	22	Metaljoint Form B
CSH-RS-G 1/2	G 1/2	10	27	Metaljoint Form B
CSH-RS-R 1/4 K	R 1/4 kegelig	17	19	Tape Form D

## CSH BULKHEAD FITTING A

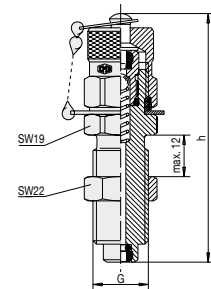

description	form	G	h	SW
CSH SK	A	M 16 x 2	72	19

## CSH BULKHEAD FITTING B

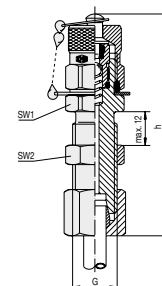

description	form	G	h		SW1	SW2
CSH SK 8-S	B	M 16 x 1.5*	72	compression ring assembly 8 S/12 L acc. to DIN 2353	22	22
CSH SK 12-L	B	M 18 x 1.5*	72	compression ring assembly 8 S/12 L acc. to DIN 2353	22	22

# CONTROL SYSTEM

CSH TEST FITTINGS WITH SCREW LOCK 630 BAR

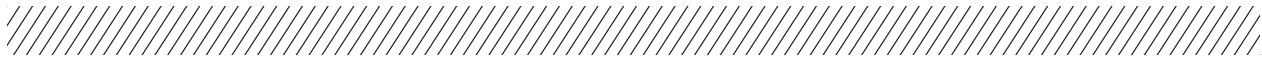

## CSH THREAD TYPE ADAPTOR A

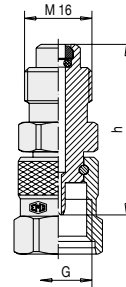

description	form	G1	G2	h1	h2	SW1	
CSAD/CSH-CSS	A	M 16 x 2	M 16 x 1.5	39	56	17	
CSAD/CSH-CS 12	A	M 16 x 2	S 12x1.5	39	50	17	butress thread S 12.65 x 1.5

## CSH THREAD TYPE ADAPTOR B

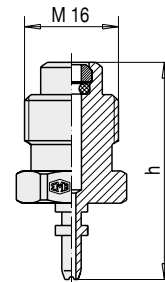

description	form	G	h
CSAD/CSH-CST	B	CST	37.5

## CSH WELDING ADAPTOR

Material: St 37.

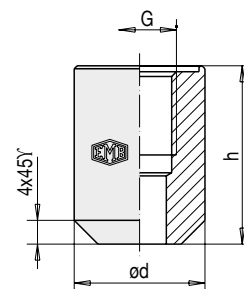

description	OD	G	h
CSAS-M 10 x 1	20	M 10 x 1	25
CSAS-G 1/4"	22	G 1/4"	30

# CONTROL SYSTEM

CSS TEST FITTINGS WITH SCREW LOCK 630 BAR

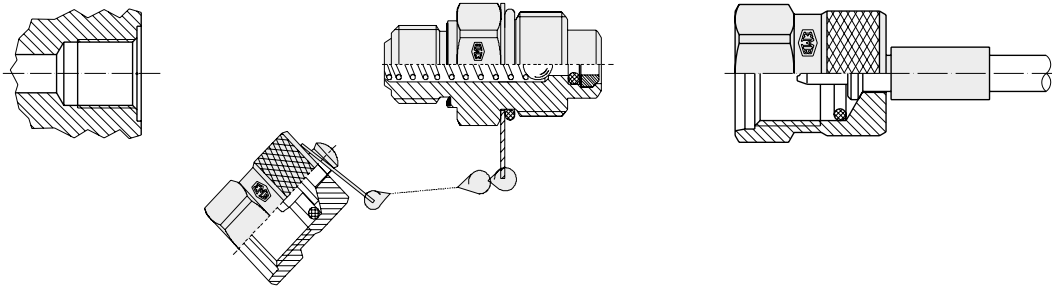

## CSS SYSTEM INTRODUCTION

### CSS application

- Monitoring and control of pressure.
- Venting and sampling in high, low and vacuum systems up to 630 bar working pressure.

### CSS advantages

- Fitting at system pressure level.
- Leak proof connection before ball valve is open.
- Simple connection with measuring, control and switching devices.
- Self-locking metal guard cap.

### CSS materials

- Metal parts: Steel, Stainless Steel on request.
- Ball: Stainless Steel.
- Seals (add the letter to the description):
  - P = Buna N (Temperature range -20 °C to +90 °C).
  - VIT = Viton (Temperature range -20 °C to +200 °C).
  - E = Ethylene Propylene on request (for brake fluid).
- Data in this catalogue is according to technical standard current at the time of printing and is subject to change without notification.

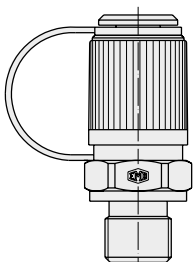

The complete CSS range is available with hexagonal steel or plastic caps

# CONTROL SYSTEM

CSS TEST FITTINGS WITH SCREW LOCK 630 BAR



## CSS TEST FITTING WITH SCREW LOCK

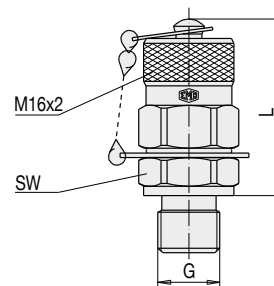

description	G	L	SW	sealing
CSS M 10 x 1	M 10 x 1	38	17	O-Ring Form A
CSS M 14 x 1.5	M 14 x 1.5	37	19	Metaljoint Form B
CSS M 16 x 1.5	M 16 x 1.5	37	22	Metaljoint Form B
CSS R 1/4"	R 1/4"	37	19	Metaljoint Form B
CSS R 1/4"/WD	R 1/4"	37	19	WD Form C
CSS R 1/4" K	R 1/4" K	35	17	Taper Form D
CSS R 3/8"	R 3/8"	37	22	Metaljoint Form B
CSS 1/4" NPT	1/4" NPT	35	17	Taper Form D
CSS 9/16" UNF	9/16"-18 UNF	38	19	O-Ring Form E

Please see "Engineering and technical data - Selecting the correct tube fitting" for more information on port connections and seals.



# CONTROL SYSTEM

CSS TEST FITTINGS WITH SCREW LOCK 630 BAR



## CSS TEST FITTING FOR CUTTING RING CONNECTION E

Model E: Test fitting with straight fitting.

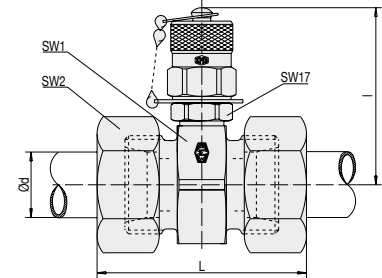

description	PN series	pipe OD	l	SW1	SW2
DS-CSSE 6-L	L 315	6	48.0	22	14
DS-CSSE 8-L		8	49.0	24	17
DS-CSSE 10-L		10	49.0	24	19
DS-CSSE 12-L		12	51.0	27	22
DS-CSSE 15-L		15	53.0	30	27
DS-CSSE 18-L		18	53.0	32	32
DS-CSSE 22-L	L 160	22	55.0	36	36
DS-CSSE 28-L		28	57.5	41	41
DS-CSSE 35-L		35	60.0	46	50
DS-CSSE 42-L		42	65.0	55	60
DS-CSSE 6-S	S 630	6	49.0	24	17
DS-CSSE 8-S		8	49.0	24	19
DS-CSSE 10-S		10	49.0	24	22
DS-CSSE 12-S		12	49.0	24	24
DS-CSSE 14-S	S 400	14	51.0	27	27
DS-CSSE 16-S		16	52.0	30	30
DS-CSSE 20-S		20	53.0	32	36
DS-CSSE 25-S		25	58.0	41	46
DS-CSSE 30-S	S 315	30	60.0	46	50
DS-CSSE 38-S		38	65.0	55	60

# CONTROL SYSTEM

CSS TEST FITTINGS WITH SCREW LOCK 630 BAR



## CSS TEST FITTING FOR CUTTING RING CONNECTION S

Model S: Test fitting with taper and O-ring.

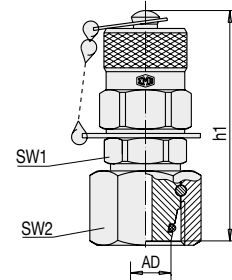

description	PN series	pipe OD	h <sub>1</sub>	h <sub>2</sub>	SW1	SW2	
CSSS 6-L	L 315	6	53		14	17	
CSSS 8-L		8	53		17	17	
CSSS 10-L		10	50		19	17	
CSSS 12-L		12	50		22	17	
CSSS 15-L		15	51		27	19	
CSSS 18-L		18		22	32		
CSSS 22-L	L 160	22		22	36		
CSSS 28-L		28		24	41		
CSSS 35-L		35		27	50		
CSSS 42-L		42		28	60		
CSSS 6-S		S 630	6	54		17	17
CSSS 8-S			8	51		19	17
CSSS 10-S	10		51		22	17	
CSSS 12-S	12		51		24	17	
CSSS 14-S	S 400	14		20	27	19	
CSSS 16-S		16		20	30		
CSSS 20-S		20		25	36		
CSSS 25-S		25		27	46		
CSSS 30-S	S 315	30		29	50		
CSSS 38-S		38		32	60		

## CSS DIRECT GAUGE ADAPTOR

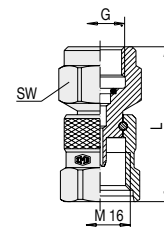

description	G	L	SW
CSSD-G 1/4	G 1/4	54	19
CSSD-G 1/2	G 1/2	58	27
CSSD-1/4 NPT	1/4 NPT	53	19
CSSD-1/2 NPT	1/2 NPT	61	27

# CONTROL SYSTEM

CSS TEST FITTINGS WITH SCREW LOCK 630 BAR



## CSS GAUGE ADAPTOR

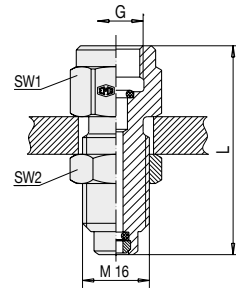

description	G	L	SW1	SW2
CSS0-R 1/4"	G 1/4	57	19	19
CSS0-R 1/2"	G 1/2	66	27	19
CSS0-1/4 NPT	1/4 NPT	55	19	19
CSS0-1/2 NPT	1/2 NPT	64	27	19

## CSS REDUCING FITTING

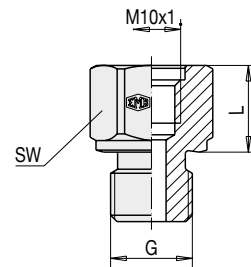

description	G	L	SW	sealing
CSS-RS-M 18 x 1.5	M 18 x 1.5	10	24	Metaljoint Form B
CSS-RS-M 20 x 1.5	M 20 x 1.5	10	27	Metaljoint Form B
CSS-RS-G 3/8	G 3/8	18	22	Metaljoint Form B
CSS-RS-G 1/2	G 1/2	18	27	Metaljoint Form B

# CONTROL SYSTEM

CSS TEST FITTINGS WITH SCREW LOCK 630 BAR



## CSS BULKHEAD FITTING A

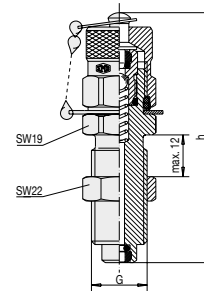

description	G	h	form	SW
CSS SK	M 16 x 2	72	A	19

## CSS BULKHEAD FITTING B

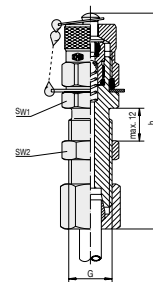

description	G	h	form	SW1	SW2
CSS SK 8-S	M 16 x 1.51)	74	B	22	22

# CONTROL SYSTEM

CSS TEST FITTINGS WITH SCREW LOCK 630 BAR



## CSS THREAD TYPE ADAPTOR A

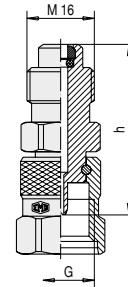

description	G	h	form
CSAD/CSS-CSH	M 16 x 2	39	A
CSAD/CSS-CS 12	S12*	39	A

\* Special thread S 12,65 x 1,5

## CSS THREAD TYPE ADAPTOR B

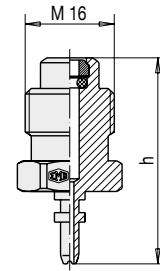

description	G	h	form
CSAD/CSS-CST	CST	37.5	B

## CSS WELDING ADAPTOR

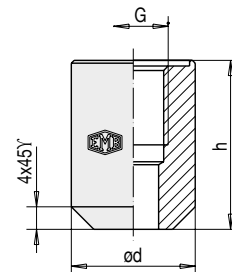

description	OD	G	h
CSAS-M 10 x 1	20	M 10 x 1	25
CSAS-G 1/4"	22	G 1/4"	30

# CONTROL SYSTEM

CSHK TEST FITTINGS WITH SCREW LOCK 630 BAR

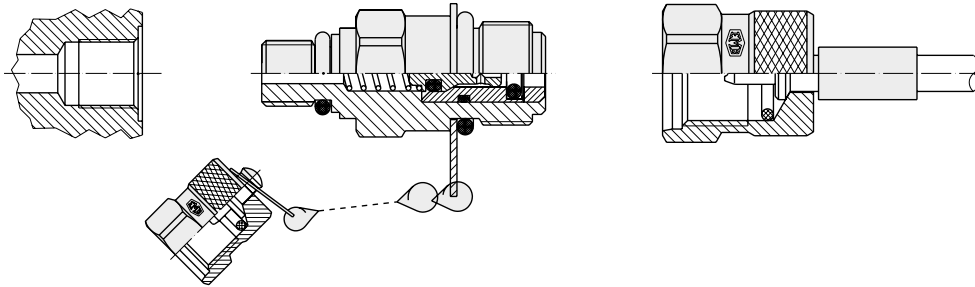
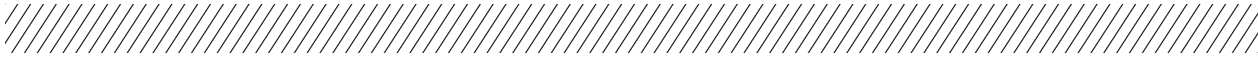

## CSHK SYSTEM INTRODUCTION

### CSHK application

- Monitoring and control of pressure.
- Venting and sampling in high, low and vacuum systems up to 630 bar working pressure.
- Connecting under pressure up to 400 bar.

### CSHK advantages

- Fitting at system pressure level.
- Leak proof connection before ball valve is open.
- Simple connection with measuring, control and switching devices.
- Self-locking metal guard cap.

### CSHK materials

- Metal parts: Steel, Stainless Steel on request.
- Ball: Stainless Steel.
- Seals (add the letter to the description):  
P = Buna N (Temperature range -20 °C to +90 °C).  
VIT = Viton (Temperature range -20 °C to +200 °C).  
E = Ethylene Propylene on request (for brake fluid).
- Data in this catalogue is according to technical standard current at the time of printing and is subject to change without notification.

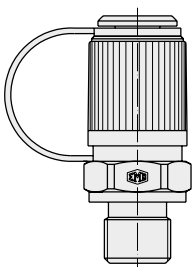

The complete CSHK range is available with hexagonal steel or plastic caps

# CONTROL SYSTEM

CSHK TEST FITTINGS WITH SCREW LOCK 630 BAR



## CSHK TEST FITTING WITH SCREW LOCK

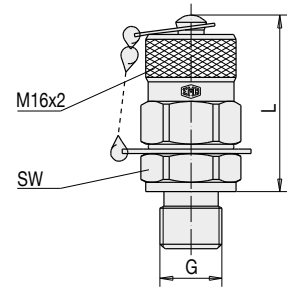

description	G	L	SW	sealing
CSHK M 8 x 1	M 8 x 1	38	17	O-Ring Form A
CSHK M 10 x 1	M 10 x 1	38	17	O-Ring Form A
CSHK M 12 x 1.5/WD	M 12 x 1.5	39	17	WD Form C
CSHK M 14 x 1.5	M 14 x 1.5	37	19	Metaljoint Form B
CSHK M 16 x 1.5	M 16 x 1.5	37	22	Metaljoint Form B
CSHK R 1/8"/WD	R 1/8"	39	17	WD Form C
CSHK R 1/8" K	R 1/8" K	36	17	Taper Form D
CSHK R 1/4"	R 1/4"	37	19	Metaljoint Form B
CSHK R 1/4"/WD	R 1/4"	37	19	WD Form C
CSHK R 1/4" K	R 1/4" K	35	17	Taper Form D
CSHK R 3/8"	R 3/8"	37	22	Metaljoint Form B
CSHK 1/8" NPT	1/8" NPT	36	17	Taper Form D
CSHK 1/4" NPT	1/4" NPT	35	17	Taper Form D
CSHK 5/16" UNF	5/16"-24 UNF	38	17	O-Ring Form E
CSHK 1/2" UNF	1/2"-20 UNF	38	17	O-Ring Form E
CSHK 7/16" UNF	7/16"-20 UNF	38	17	O-Ring Form E
CSHK 9/16" UNF	9/16"-18 UNF	38	19	O-Ring Form E

Please see "Engineering and technical data - Selecting the correct tube fitting" for more information on port connections and seals.

# CONTROL SYSTEM

CSHK TEST FITTINGS WITH SCREW LOCK 630 BAR



## CSHK TEST FITTING FOR CUTTING RING CONNECTION E

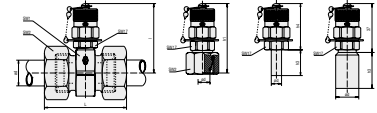

description	PN series	pipe OD	l	SW1	SW2
DS-CSHKE 6-L	L 315	6	48.0	22	14
DS-CSHKE 8-L		8	49.0	24	17
DS-CSHKE 10-L		10	49.0	24	19
DS-CSHKE 12-L		12	51.0	27	22
DS-CSHKE 15-L		15	53.0	30	27
DS-CSHKE 18-L		18	53.0	32	32
DS-CSHKE 22-L		22	55.0	36	36
DS-CSHKE 28-L		L 160	28	58.0	41
DS-CSHKE 35-L	35		60.0	46	50
DS-CSHKE 42-L	42		65.0	55	60
DS-CSHKE 6-S	S 630	6	49.0	24	17
DS-CSHKE 8-S		8	49.0	24	19
DS-CSHKE 10-S		10	49.0	24	22
DS-CSHKE 12-S		12	49.0	24	24
DS-CSHKE 14-S	S 400	14	51.0	27	27
DS-CSHKE 16-S		16	52.0	30	30
DS-CSHKE 20-S		20	53.0	32	36
DS-CSHKE 25-S		25	58.0	41	46
DS-CSHKE 30-S	S 315	30	60.0	46	50
DS-CSHKE 38-S		38	65.0	55	60



# CONTROL SYSTEM

CSHK TEST FITTINGS WITH SCREW LOCK 630 BAR



## CSHK TEST FITTING FOR CUTTING RING CONNECTION S

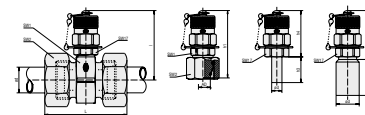

description	PN series	pipe OD	h <sub>1</sub>	h <sub>2</sub>	SW1	SW2
CSHKS 6-L	L 315	6	53		14	17
CSHKS 8-L		8	53		17	17
CSHKS 10-L		10	50		19	17
CSHKS 12-L		12	50		22	17
CSHKS 15-L		15	51		27	19
CSHKS 18-L		18			22	32
CSHKS 22-L	L 160	22		22	36	
CSHKS 28-L		28		24	41	
CSHKS 35-L		35		27	50	
CSHKS 42-L		42		28	60	
CSHKS 6-S	S 630	6	54		17	17
CSHKS 8-S		8	51		19	17
CSHKS 10-S		10	51		22	17
CSHKS 12-S		12	51		24	17
CSHKS 14-S	S 400	14		24	27	19
CSHKS 16-S		16		20	30	
CSHKS 20-S		20		25	36	
CSHKS 25-S	S 315	25		27	46	
CSHKS 30-S		30		29	50	
CSHKS 38-S		38		32	60	

# CONTROL SYSTEM

PRESSURE TEST KIT



**CST 1, 2, 3**

**CSH 1, 2, 3**

**CSS 1, 2, 3**

Bespoke complement on customer's request.

# CONTROL SYSTEM

PRESSURE GAUGE



## CMM PRESSURE GAUGE

Glycerin filled.

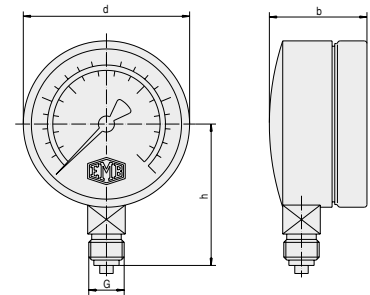

description	description	pressure range				
<b>G = G 1/4</b>	<b>G = 1/4 NPT</b>	<b>bar</b>	<b>psi</b>	<b>d</b>	<b>b</b>	<b>h</b>
CMM G 1/4-10	CMM 1/4 NPT-10	10	145	63	35.5	53
CMM G 1/4-16	CMM 1/4 NPT-16	16	230	63	35.5	53
CMM G 1/4-25	CMM 1/4 NPT-25	25	360	63	35.5	53
CMM G 1/4-40	CMM 1/4 NPT-40	40	580	63	35.5	53
CMM G 1/4-60	CMM 1/4 NPT-60	60	870	63	35.5	53
CMM G 1/4-100	CMM 1/4 NPT-100	100	1450	63	35.5	53
CMM G 1/4-160	CMM 1/4 NPT-160	160	2300	63	35.5	53
CMM G 1/4-250	CMM 1/4 NPT-250	250	3600	63	35.5	53
CMM G 1/4-400	CMM 1/4 NPT-400	400	5800	63	35.5	53
CMM G 1/4-600	CMM 1/4 NPT-600	600	8700	63	35.5	53

description	description	pressure range				
<b>G = G 1/2</b>	<b>G = 1/2 NPT</b>	<b>bar</b>	<b>psi</b>	<b>d</b>	<b>b</b>	<b>h</b>
CMM G 1/2-10	CMM 1/2 NPT-10	10	145	100	49	87
CMM G 1/2-16	CMM 1/2 NPT-16	16	230	100	49	87
CMM G 1/2-25	CMM 1/2 NPT-25	25	360	100	49	87
CMM G 1/2-40	CMM 1/2 NPT-40	40	580	100	49	87
CMM G 1/2-60	CMM 1/2 NPT-60	60	870	100	49	87
CMM G 1/2-100	CMM 1/2 NPT-100	100	1450	100	49	87
CMM G 1/2-160	CMM 1/2 NPT-160	160	2300	100	49	87
CMM G 1/2-250	CMM 1/2 NPT-250	250	3600	100	49	87
CMM G 1/2-400	CMM 1/2 NPT-400	400	5800	100	49	87
CMM G 1/2-600	CMM 1/2 NPT-600	600	8700	100	49	87

## ADJUSTABLE GAUGE FITTING

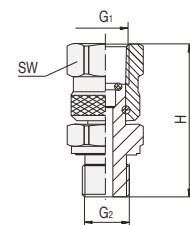

description	G1	G2	H	SW
VO-1/4	1/4	1/4	42.0	19
VO-1/4-1/2	1/4	1/2	47.0	19
VO-1/2-1/4	1/2	1/4	52.0	27
VO-1/2	1/2	1/2	55.5	27

# CONTROL SYSTEM

HOSE CONNECTOR



## HOSE ORDER DESCRIPTION

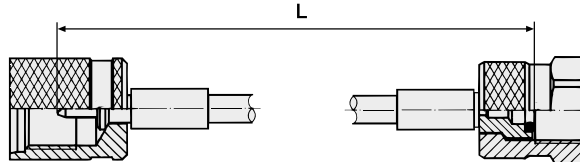

<b>CS...MS<sup>1)</sup></b>			<b>1500</b>	<b>T</b>	<b>not specified DN</b>	
<b>Connection 1</b>			<b>Length L</b>	<b>Connection 2</b>		
H	A	J	hose length in mm	H	A	J
S	S	D		S	S	D
T	K	B		T	K	B
12	L	U		12	L	U
M	G	P		M	G	P
N	F			N	F	
W	C			W	C	
				A	= DN2 400 bar	
				B	= DN2 630 bar	
				C	= DN4 340 bar	

1) Order code of hose for gaseous medium "CS...MSG"

for different connection on second side only

## HOSE CONNECTOR

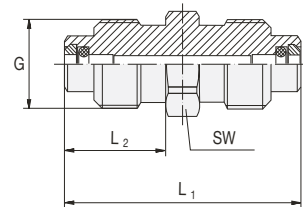

description	G	L1	SW
CSHMSAD	M16X2	42	17
CSSMSAD	M16x1.5	42	17
CS12MSAD	S12x1.5	44	19

# CONTROL SYSTEM

HOSE FITTINGS | HOSE FITTING FOR CONTROL SYSTEM

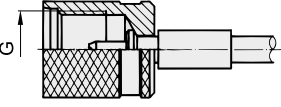

## HOSE FITTING TYPE HS

description	hose fitting	type	G	SW	DN
Rows of screws Connection for test fittings		H S	M16x2 M16x1.5		2 and 4

## HOSE FITTING TYPE 12

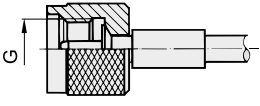
description	hose fitting	type	G	SW	DN
Rows of screws Connection for test fittings		12	S12.65x1.5		2 and 4

## HOSE FITTING TYPE O

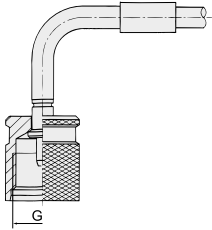
description	hose fitting	type	G	SW	DN
Rows of screws 90° bent Connection for test fittings		H S 12	M16x2 M16x1.5 S12.65x1.5		2

## HOSE FITTING TYPE T CONNECT

description	hose fitting	type	G	SW	DN
Plugging line		T	connector system		2

# CONTROL SYSTEM

HOSE FITTINGS | HOSE FITTINGS FOR CONTROL SYSTEM



## HOSE FITTING TYPE M

description	hose fitting	type	G	SW	DN	
Manometer connection Whitworth pipe thread G3/8 and G1/2 outer line See depiction type N		M	1/4	G1/4	19	2 and 4
			1/2	G1/2	27	
			3/8	G3/8	22	2

## HOSE FITTING TYPE W

description	hose fitting	type	G	SW	DN	
Manometer connection Whitworth pipe thread 90° bent G3/8 and G1/2 outer line See depiction type N		W	1/4	G1/4	19	2
			1/2	G1/2	27	

## HOSE FITTING TYPE N

description	hose fitting	type	G	SW	DN	
Manometer connection With 1/4" NPT outer line See depiction type M		N	1/4	1/4 NPT	19	2
			1/2	1/2 NPT	27	

# CONTROL SYSTEM

HOSE FITTINGS | HOSE FITTINGS FOR CONTROL SYSTEM

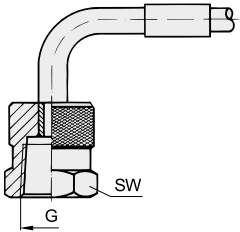

## HOSE FITTING TYPE A

description	hose fitting	type	G	SW	DN	
Manometer connection NPT 90° bent With 1/4" NPT outer line depiction type M	See 	A	1/4	1/4 NPT	19	2 and 4
			1/2	1/2 NPT	27	

## HOSE FITTING TYPE S

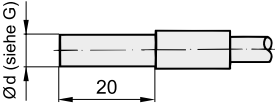
description	hose fitting	type	G	SW	DN	
Pipe socket for compression type fitting acc. to DIN 2353		S	4	4LL		2
			6	6L - 6S		2 and 4
			8	8L - 8S		2 and 4
			10	10L - 10S		2 and 4
			12	12L - 12S		2
			15	15L		2
			1/4	1/4"		2 and 4

## HOSE FITTING TYPE S90°

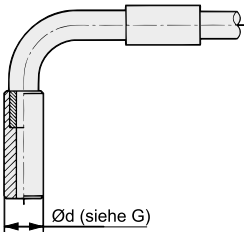
description	hose fitting	type	G	SW	DN
Pipe socket for compression type fitting according to DIN 2353		S90° upon request			2 and 4

# CONTROL SYSTEM

HOSE FITTINGS | HOSE FITTING FOR CONTROL SYSTEM



## HOSE FITTING TYPE K

description	hose fitting	type	G	SW	DN	
Conical nipple with swivel nut and O-ring for 24° connectors		K	6LL	M10x1.0	12	4
			6L	M12x1.5	14	2 and 4
			8L	M14x1.5	17	2 and 4
			10L	M16x1.5	19	2 and 4
			12L	M18x1.5	22	2 and 4
			6S	M14x1.5	17	2 and 4
			8S	M16x1.5	19	2 and 4
			10S	M18x1.5	22	2 and 4
			12S	M20x1.5	24	2 and 4

## HOSE FITTING TYPE R

description	hose fitting	type	G	SW	DN	
Conical nipple with swivel nut and O-Ring for 24° connectors 45° bent		R	6S	M14x1.5	17	2 and 4

## HOSE FITTING TYPE L

description	hose fitting	type	G	SW	DN	
Conical nipple with swivel nut and O-Ring for 24° connectors 90° bent		L	6L	M12x1.5	14	2 and 4
			8L	M14x1.5	17	
			10L	M16x1.5	19	
			6S	M14x1.5	17	
			8S	M16x1.5	19	
			10S	M18x1.5	24	



# CONTROL SYSTEM

HOSE FITTINGS | HOSE FITTING FOR CONTROL SYSTEM



## HOSE FITTING TYPE G

description	hose fitting	type	G	SW	DN	
External thread complying with DIN 3852-B		G	12	M12x1.5	17	2 and 4
			1/8	G 1/8	14	
			1/4	G 1/4	19	
			1/2	G 1/2	27	

## HOSE FITTING TYPE F

description	hose fitting	type	G	SW	DN	
External thread NPT acc. to ANSI		F	1/8	1/8 NPT	13	2 and 4
			1/4	1/4 NPT	17	

## HOSE FITTING TYPE C

description	hose fitting	type	G	SW	DN	
External thread for 24° compression fitting acc. to DIN 3853		C	6L	M12x1.5	14	2 and 4
			8L	M14x1.5	17	
			6S	M14x1.5	17	
			8S	M16x1.5	17	

# CONTROL SYSTEM

HOSE FITTINGS | HOSE FITTING FOR CONTROL SYSTEM



## HOSE FITTING TYPE J

description	hose fitting	type	G			DN
			G	SW	DN	
External thread acc. to SAE J514		J	1/4	7/16-UNF	14	2 and 4
			5/16	1/2-UNF	14	
			3/8	9/16-UNF	17	

## HOSE FITTING TYPE D

description	hose fitting	type	G			DN
			G	SW	DN	
Conical pipe with swivel nut for 24° connector acc. to DIN 2353		D	6L	M12x1.5	14	2 and 4
			8L	M14x1.5	17	
			10L	M16x1.5	19	
			12L	M18x1.5	22	
			6S	M14x1.5	17	
			8S	M16x1.5	19	
			10S	M18x1.5	22	
			12S	M20x1.5	24	

## HOSE FITTING TYPE Q

description	hose fitting	type	G			DN
			G	SW	DN	
Conical pipe with swivel nut for 24° connector acc. to DIN 2353 standards 90° bent		Q	10L	M16x1.5	19	2 and 4
			10S	M18x1.5	22	

# CONTROL SYSTEM

HOSE FITTINGS | HOSE FITTING FOR CONTROL SYSTEM



## HOSE FITTING TYPE B

description	hose fitting	type	G	SW	DN		
Conical pipe with swivel nut acc. to DIN 8542		B	1/4	G 1/4	17	2 and 4	

## HOSE FITTING TYPE U

description	hose fitting	type	G	SW	DN	
Conical pipe with swivel nut complying with SAE J514 for 37° connector		U	1/4	7/16-20 UNF	14	2 and 4
			5/16	1/2-20UNF	17	
			3/8	9/16-18UNF	19	

## HOSE FITTING TYPE UR

description	hose fitting	type	G	SW	DN		
Conical pipe with swivel nut complying with SAE J516 for 45° connectors		UR	1/4	7/16-20UNF	14	2	

# CONTROL SYSTEM

HOSE FITTINGS | HOSE FITTING FOR CONTROL SYSTEM



## HOSE FITTING TYPE E

description	hose fitting	type	G	SW	DN	
Conical pipe with swivel nut acc. to SAE J514 for 37° connector 90° bent		E	1/4	7/16-20UNF	14	2

## HOSE FITTING TYPE ER

description	hose fitting	type	G	SW	DN	
Conical pipe with swivel nut acc. to SAE J514 for 45° connector 90° bent		ER	1/4	7/16-20UNF	14	2

## HOSE FITTING TYPE P

description	hose fitting	type	G	SW	DN	
Measuring hose for vehicle brake systems		P	2	M16x1.5	19	2

# CONTROL SYSTEM

HOSE FITTINGS | HOSE FITTING FOR CONTROL SYSTEM



## HOSE FITTING TYPE H

description	hose fitting	type	G	SW	DN	
Conical pipe with swivel nut for 60° connector		H	1/4	G 1/4	17	4

## HOSE FITTING TYPE T

description	hose fitting	type	G	SW	DN	
Screwed connection ORS acc. to SAE J1453		T	11/16	11/16-16 UN	21	2

## HOSE FITTING TYPE V

description	hose fitting	type	G	SW	DN	
Screwed connection ORS acc. to SAE J 1453 90° bent		V	11/16	11/16-16UN	21	2 and 4



**DRIVEN BY POSSIBILITY™**

# **9. MACHINERY**



**Gates assembly machinery can help you to cut maintenance costs, boost productivity and outperform others thanks to our focus on design, innovation and top-quality materials. The range covers all your needs from workshops to mobile service operations and even on-site field crimping.**

Today, cutting ring and flaring are still the main technologies used to connect tubes. To guarantee leak-free results, the joint procedure requires reliable machines that support the quality of the connection. Therefore, we pay meticulous attention to quality standards in all cutting ring assembly, flaring, tube end forming, tube manipulation, cutting, crimping, and marking, and conduct extensive quality testing before shipment. Thanks to the Gates assembly machines' accurate processes, a minimum of the operator's individual intervention is required, reducing the need for manual justifications as well as process control.



## OPTICAM 4S CUTTING RING ASSEMBLY MACHINE

Hydraulic operating machine with SPC unit (storage programmable control) for both pre-assembly and final assembly of cutting rings. Its fully automated assembly process ensures 100% accuracy and removes the need for any rework or manual intervention, providing the customer with the guarantee of a leak-free connection.

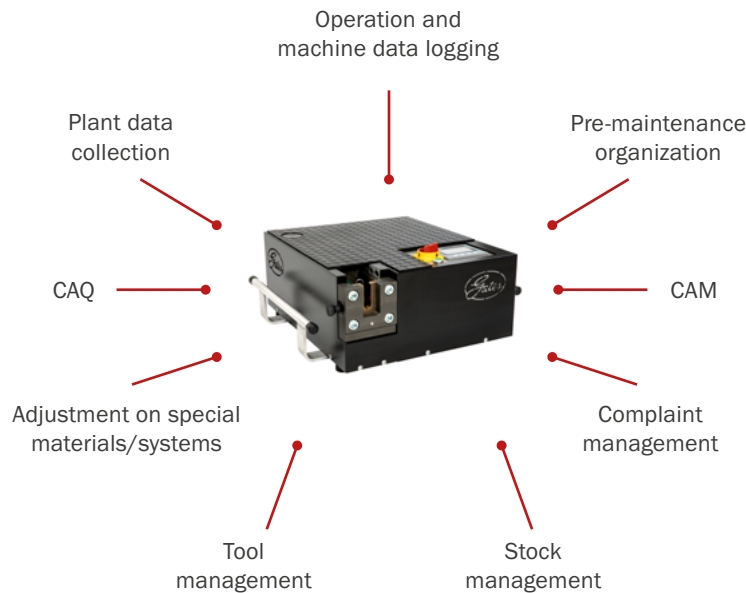

All new Opticam models are equipped with Gates CORTEX operation software that can be linked to external devices such as CAQ, CAM, preventative maintenance, ERP-systems, and others. This innovative feature can transfer operational data to enable analysis (e.g., assemblies/hour), as well as record the technical specifications applied to each assembly. This ability to monitor and detect will support machine uptime in the field, while maximizing the total cost of ownership of capital equipment. With this tool the traceability of single assemblies is made easy.

# MACHINERY

CUTTING RING ASSEMBLY & FLARING MACHINERY



## PRODUCT FEATURES

- 100% assembly-security by process control. The Opticam software indicates mistakes by distance and pressure control
  - Wear of tool detection
  - Detection of incorrect cutting-ring orientation
  - Defective cutting-ring detection
  - Double assembly detection
  - Wrong nut selection detection
  - Detection of dimensional deviations within the different parts
  - Tube burr detection
  - Etc.
- The software allows process control and documentation.
- Up to 10 different cutting ring programme places available
- Color touch screen display showing additional information and enabling language selection
- The machine is equipped with a RJ45 socket for connection to PC. The PC is used to program the machine and to record assembly data.
- The machine meets the requirements of accident prevention.
  - For security reasons the assembling room is monitored by light barriers.
  - Assembly process is started only by the pressing the start button (or optional by using the foot pedal)
- To decrease cycle times, the machine can be equipped with a two-stage power pack

All Opticam models are specifically designed around the challenges our customers face within their manufacturing and assembly operation, ensuring complete flexibility based on our customers' needs. Therefore, the Opticam is available in 3 different versions:

- Standard version
- Sideways assembly tool version
- Detached assembly tool version, allowing you to place just the assembly tool on your work bench. The tool stays connected to the system cabin via energy and sensor lines, freeing up workspace on your bench.



Standard version

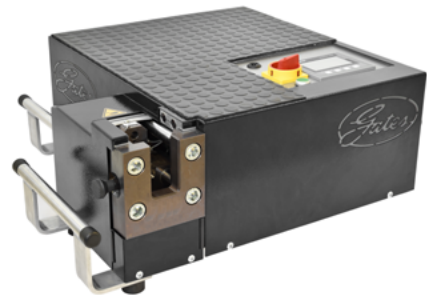

Sideways version

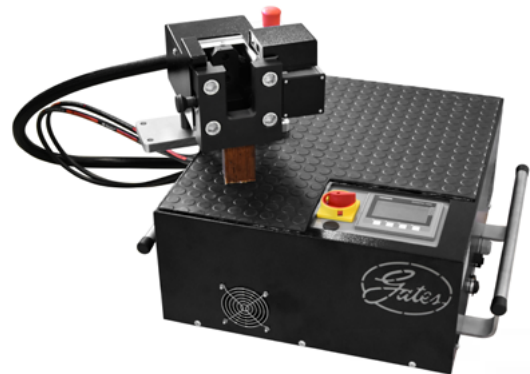

Detached version



# MACHINERY

CUTTING RING ASSEMBLY & FLARING MACHINERY



Technical Specifications Opticam 4S		CAM 4S		CAM 4S DP	
		400 V / 3-Phase		400 V / 3-Phase	
working pressure	max. bar	400		400	
assembly pressure	max. tons	20		20	
hydraulic unit	ltr./min	3		3 + 1.25	
electric drive	Hz	50		50	
dimensions (mm)	H	290		290	
	W	710		710	
	D	640		640	
weight	ca. kg	92		95 incl. oil	
cylinder movement	max. sec.	2,4	e.g. Ø 12 mm	1,9	e.g. Ø 12 mm
order code		CAM4S		CAM4SDP	

Tools	Part Number
Eccentric reception	CAMAUFEX
Contact tool switch	INIWK
Foot switch	FUSSSCHCAM3
Tool box	OPTI100

Assembly	Assembly Sockets (OPTI)	Counter Plates (OPT)
Pre-assembly	OPTI	OPT/E
Pre-assembly for eccentric reception	OPTI-EX	OPT-EX/F/S
Final assembly	OPTI/F	OPT/F
Final assembly for eccentric reception	OPTI-EX/F	OPT-EX/F/S

\*Please contact customer service to select the correct tool

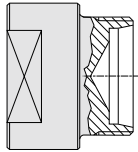
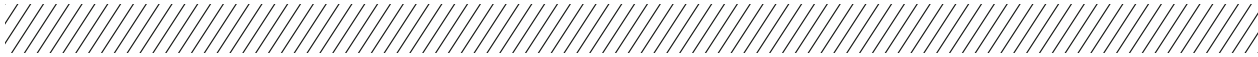

## VM PRE-ASSEMBLY BODIES

Bodies for the turning-angle-controlled serial assembly of cutting ring fittings in the pre-assembly adaptor VM with subsequent final assembly.

Technical Specifications VM Pre-Assembly Bodies				
Description	tube OD	G	L	S
VM 6-L	6	M 12 x 1.5	28	14
VM 8-L	8	M 14 x 1.5	28	14
VM 10-L	10	M 16 x 1.5	28	14
VM 12-L	12	M 18 x 1.5	28	19
VM 15-L	15	M 22 x 1.5	33	19
VM 18-L	18	M 26 x 1.5	36	24
VM 22-L	22	M 30 x 2	37	27
VM 28-L	28	M 36 x 2	40	32
VM 35-L	35	M 45 x 2	42	41
VM 42-L	42	M 52 x 2	42	50
VM 6-S	6	M 14 x 1.5	28	14
VM 8-S	8	M 16 x 1.5	28	14
VM 10-S	10	M 18 x 1.5	28	14
VM 12-S	12	M 20 x 1.5	28	19
VM 14-S	14	M 22 x 1.5	33	19
VM 16-S	16	M 24 x 1.5	33	24
VM 20-S	20	M 30 x 2	37	27
VM 25-S	25	M 36 x 2	39	32
VM 30-S	30	M 42 x 2	42	41
VM 38-S	38	M 52 x 2	42	50



## UP/M UNIPRESS CUTTING RING ASSEMBLY

Hand assembly machine allowing easy cutting-ring pre-assembly and flaring 37° systems. The light-weight, user-friendly design makes it perfect for on-site applications and repairs.

Utilises same tools as electro-hydraulic machines.

Tube flaring for 37° Gates ABO and SAE system.

Technical Specifications UP/M Unipress		UP/M
		<b>Manually</b>
tube range cutting ring assembly	mm Ø	6 to 42
tube range flaring	mm Ø	6 to 22
maximum pressure	bar	230
dimensions (mm)	H	260
	W	190
	D	400
weight	ca. kg	15
order code		UNIPRESS M

TOOLS	UP/M
Pre-assembling counter plate	OPT/E
Pre-assembling socket	OPTI
Flaring device	BÖRDELVORSATZ UPM622
Flaring tools for ABO 37°	UNI-BBO
Flaring tools SAE system	UNI-BB

## UP/M 642 UNIPRESS CUTTING RING ASSEMBLY

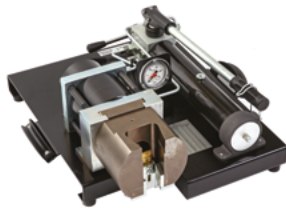

Hand assembly machine allowing easy cutting-ring pre-assembly and flaring 37° systems. The light-weight, user-friendly design makes it perfect for on-site applications and repairs.

Utilises same tools as electro-hydraulic machines.

Tube flaring for 37° Gates ABO and SAE system.



Technical Specifications UP/M 642 Unipress		UP/M 642
		<b>Manually</b>
tube range cutting ring assembly	mm Ø	6 to 42
tube range flaring	mm Ø	6 to 42
maximum pressure	bar	200
dimensions (mm)	H	180
	W	350
	D	450
weight	ca. kg	35
order code		UNIPRESS 642 H

Tools	UP/M
Pre-assembling counter plate	OPT/E
Pre-assembling socket	OPTI
Flaring device	BVORSATZ37
Flaring tools for ABO 37°	UNI-BBO
Flaring tools SAE system	UNI-BB

# MACHINERY

CUTTING RING ASSEMBLY & FLARING MACHINERY



	ABO Flaring System UNI-BBO...	SAE Flaring System UNI-BB...
<b>Tube</b>		
6	UNI-BBO 6-L/S	UNI-BB 6-L/S
8	UNI-BBO 8-L/S	UNI-BB 8-L/S
10	UNI-BBO 10-L/S	UNI-BB 10-L/S
12	UNI-BBO 12-L/S	UNI-BB 12-L/S
14	UNI-BBO 14-S	UNI-BB 14-S
15	UNI-BBO 15-L	UNI-BB 15-L
16	UNI-BBO 16-S	UNI-BB 16-S
18	UNI-BBO 18-L	UNI-BB 18-L
20	UNI-BBO 20-S	UNI-BB 20-S
22	UNI-BBO 22-L	UNI-BB 22-L
25	UNI-BBO 25-S	UNI-BB 25-S
28	UNI-BBO 28-L	UNI-BB 28-L
30	UNI-BBO 30-S	UNI-BB 30-S
35	UNI-BBO 35-L	UNI-BB 35-L
38	UNI-BBO 38-S	UNI-BB 38-S
42	UNI-BBO 42-L	UNI-BB 42-L
1/4"		UNI-BB 1/4"
5/16"		UNI-BB 5/16"
3/8"		UNI-BB 3/8"
1/2"		UNI-BB 1/2"
5/8"		UNI-BB 5/8"
3/4"		UNI-BB 3/4"
7/8"		UNI-BB 7/8"
1"		UNI-BB 1"
1.1/4"		UNI-BB 1.1/4"
1.1/2"		UNI-BB 1.1/2"

# MACHINERY

CUTTING RING ASSEMBLY & FLARING MACHINERY



## UP 4 UNIPRESS CUTTING RING ASSEMBLY & FLARING MACHINE

Universal combination machine for cutting ring pre-assembly with manual or automatic pressure setting and tube flaring for steel and stainless steel tubes with an outer diameter from 6 to 42 mm.

Technical Specifications UP 4 Unipress		UP 4
		<b>400 V / 3-Phase</b>
working pressure	max. bar	0 to 200
electric drive	Hz	50
dimensions (mm)	H	265
	W	660
	D	515
weight	ca. kg	66
order code		UNIPRESS 4
Tools		UP 4
Pre-assembling counter plate		OPT/E
Pre-assembling socket		OPTI
Flaring tools for ABO 37°		UNI-BB0
Flaring tools SAE system		UNI-BB



Tube forming is not only one of the safest methods for the connection of leak-free hydraulic tube systems but can be used as an alternative for expensive welding procedures in many cases. The result is a huge cost reduction on both labour and system assembly cost. This supports economies of scale and provides extra time and money for further projects. Operator faults are basically excluded due to automated machine functions. Gates assembly machines are developed with individual customer needs in mind like ease of use, reliability and cost performance.

## FS 94 TUBE FORMING MACHINE



The FS 94 forming machine offers fast and safe tube forming of both steel and stainless steel tubes. The forming happens in one single step with the help of the electronic power path control, reducing tool costs and operation time significantly.

Easy tube size selection via the machine display.

One tool set for different materials and tube wall thicknesses.

The bayonet catch allows very quick change of tools.

Technical Specifications FS 94		FS 94
		<b>400 V / 3-Phase</b>
electric drive	Hz	50
fuse	A	16
dimensions (mm)	H	350
	W	740
	D	860
weight	ca. kg	200
order code		FS 94 UMFORMMASCHINE

TOOLS	FS 94	
Clamping jaws	SPW	
Reshaping tools	FOW	
Function ring	FSR	Ø 6 to 42 mm
Back-up ring	FSSR	Ø 6 to 12 mm



## FINAL ASSEMBLY WITH FUNCTION & BACK-UP RING

The FSR function ring and FSR back-up ring FSSR support the final assembly, integrating an elastomer seal into the system which protects against excessive tightening. The frictional tension between tube and fitting cone is assured with the metallic seal function. The vulcanised soft seals ensure the leak-free performance in extreme working conditions. Safe assembly is guaranteed by a clearly noticeable assembly stop. It is recommended to use FSR on tube diameters from 6 to 42 mm, FSSR alternatively from 6 to 12 mm with very thin wall thicknesses.



Function Ring FSR	
Description steel	Description stainless steel
FSR 8-L/S	FSR 8-L/S-1.4571
FSR 10-L/S	FSR 10-L/S-1.4571
FSR 12-L/S	FSR 12-L/S-1.4571
FSR 15-L	FSR 15-L-1.4571
FSR 16-S	FSR 16-S-1.4571
FSR 18-L	FSR 18-L-1.4571
FSR 20-S	FSR 20-S-1.4571
FSR 22-L	FSR 22-L-1.4571
FSR 25-S	FSR 25-S-1.4571
FSR 28-L	FSR 28-L-1.4571
FSR 30-S	FSR 30-S-1.4571
FSR 35-L	FSR 35-L-1.4571
FSR 38-S	FSR 38-S-1.4571
FSR 42-L	FSR 42-L-1.4571

Back-up ring FSSR	
Description steel	Description stainless steel
FSSR 6-L/S	FSSR 6-L/S-1.4571
FSSR 8-L/S	FSSR 8-L/S-1.4571
FSSR 10-L/S	FSSR 10-L/S-1.4571
FSSR 12-L/S	FSSR 12-L/S-1.4571



Tools SPW		
Description	Tube OD mm	Wall Thickness mm
SPW 6L/S	6	1-1.5
SPW 8L/S	8	1-2.5
SPW 10L/S	10	1-3.0
SPW 12L/S	12	1-3.5
SPW 15L/S	15	2-3.0
SPW 16L/S	16	2-4.0
SPW 18L/S	18	2-3.0
SPW 20L/S	20	2.5-4.0
SPW 22L/S	22	2-3.5
SPW 25L/S	25	2.5-5.0
SPW 28L/S	28	2.5-5.0
SPW 30L/S	30	3-6.0
SPW 35L/S	35	2.5-6.0
SPW 38L/S	38	3-6.0
SPW 42L/S	42	3-4.0

Tools SPW		
Description	Tube OD mm	Wall Thickness mm
FOW 6X1-1.5 L/S	6	1-1.5
FOW 8X1-1.5 L/S	8	1-1.5
FOW 8X2+L/S	8	2-2.5
FOW 10X1-1.5L/S	10	1-1.5
FOW 10X2+L/S	10	2-3.0
FOW 12X1-1.5L/S	12	1-1.5
FOW 12X2+L/S	12	2-3.5
FOW 15X2+	15	2-3.0
FOW 16X2+	16	2-4.0
FOW 18X2+	18	2-3.0
FOW 20X2,5+	20	2.5-4.0
FOW 22X2+	22	2-3.5
FOW 25X2,5+	25	2.5-5.0
FOW 28X2,5+	28	2.5-5.0
FOW 30X3+	30	3-6.0
FOW 35X2,5+	35	2.5-6.0
FOW 38X3+	38	3-6.0
FOW 42X3+	42	3-4.0



## MOBILPRESS PB 642 TUBE BENDING MACHINE

Machine for hydraulic bending of tubes of 6-42 mm in steel St35, St37, St52 as well as stainless steel tubes. The maximum bending efficiency is 38x5 mm resp. 42x4 mm.

Three different machines are available.

PBEH 642 F

PBEH 642

PBM 642

Technical Specifications PB 642 Mobilpress		PBEH 642 F	PBEH 642	PBM 642
		<b>400 V / 3-Phase</b>	<b>400 V / 3-Phase</b>	<b>manual</b>
operating pressure	max. bar	250	250	
electric drive	Hz	50	50	
weight	ca. kg	70	70	
tube bending efficiency	mm diameter x wall thickness	38x5 or 42x4	38x5 or 42x4	
order code		PRESSBIEGER PBEH642F	PRESSBIEGER PBEH642MDB	PRESSBIEGER PBM642MDB

Tools	PB 642
Bending matrix	TPM
Bending wind head	TPG
Deburring unit	ENTGRATERPBF
Electrohydraulic power unit	ANTRIEBSPBEHF
Cutting ring pre-assembly unit	SCHVORSATZPB3
37° Flaring unit (6 to 42mm)	BVORSATZ37UP3

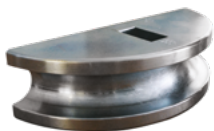

**BENDING TOOLS  
TPM**

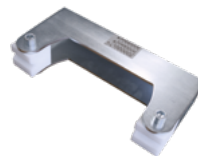

**BENDING WING HEADS  
TPG**

Tools TPM			
Description	Tube OD mm; inch	Thread Tube OD mm	Bending Radius
TPM 06	6		2.0xD
TPM 08	8		2.0xD
TPM 10	10		2.0xD
TPM 12	12		2.0xD
TPM 14	14; 1/4	13.5	2.0xD
TPM 15	15		2.0xD
TPM 16	16		2.0xD
TPM 18	18; 3/8	17.2	2.5xD
TPM 20	20		2.0xD
TPM 22	22; 1/2	21.3	2.5xD
TPM 25	25		2.4xD
TPM 28	28; 3/4	26.9	2.7xD
TPM 30	30		2.5xD
TPM 35	35; 1	33.7	3.0xD
TPM 38	38		2.5xD
TPM 42	42; 1 1/4	42.1	3.0xD

Tools TPG	
Description	Tube OD mm
TPG 6/8	6 + 8
TPG 10/12	10 + 12
TPG 14/16	14 + 16
TPG 18/20	18 + 20
TPG 22/25	22 + 25
TPG 28/30	28 + 30
TPG 35/38	35 + 38
TPG 42	42





## RBV 6/18 TUBE BENDING DEVICE

This device comes with 6 changeable bending rollers for tubes from 6 to 18 mm.

Weight of each piece: approx. 4 kg

Ease-of-use: ideal for workshop independent, mobile bending operations.

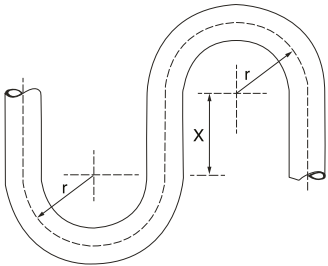

Technical Specifications RBV 6/18

Description	Tube OD mm	Gas Tube	r	~ x	~ kg/pc
RBV 6/18	6		33.0	35	4
	8		34.0	35	
	10	1/8	35.5	35	
	12		36.5	35	
	14	1/4	36.5	35	
	15		44.0	38	
	16		44.0	38	
	18	3/8	51.5	42	



**Gates cutters – both the hose cutters and steel tube cutters - are robust and compact machines, and distinguish themselves by their safe and high-quality cutting function.**

Our range of electrical cutters is all hand controlled for guided cutting thus allowing for optimal speed control and a reduction of blade damage. The blades are positioned close to the powerful motors to limit vibration which enhances the durability and reduces maintenance costs. But there is more: low energy consumption, CE compliant brake motors for 3-phase cutting machines, built-in protection, limited smoke production ... all supporting your safe working environment and personnel safety.

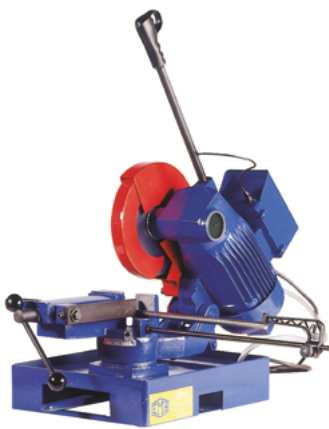

**UNICUT TC 080 METAL SAW**

Unicut is a compact transportable hand circular saw for all types of metal tubes. The saw can be used for straight and mitre cuts, has an integrated automatic cooler and offers best performance for accurate cuts in order to fit tubes perfectly.

Saw blades high-speed steel with DMO surface coating.

Dimension 250 x 2.0 x 32 with 2 side holes 12/64 mm.

CUTTING SECTION		45°	90°
	mm Ø	70	80
	mm Ø	40	40
	mm	60	70
	mm	40	40
	mm	65x60	95x60

Technical Specifications Unicut TC 080		TC 080	TC 080
		400 V / 3-Phase	220 V
mitre cuts		up to 45°	up to 45°
electric drive	kW/Hz	1.0/50	0.8/50
weight	ca. kg	71	71
rotational speed	rev/min	52	52
dimensions (mm)	H	700	700
	W	850	850
	D	450	450
order code		UNICUT TC 080/380V	UNICUT TC 080/220V

Tools	TC 080
Saw blade for thick-walled profiles and solid materials	HSS-SÄGEBLATT 250/128
Saw blade for thin-walled profiles and tubes	HSS-SÄGEBLATT 250/200



## OPTIGRAT OG 642 TUBE DEBURRING MACHINE

Electrically driven deburring unit for quick and clean inner and outer deburring of tubes from 6 to 42 mm diameter. The device is made of HSS steel to ensure mark-free deburring with extraordinary service life.

Technical Specifications OG 642 Optigrat		OG 642
		<b>400 V / 3-Phase</b>
rotational speed inner deburring	rev/min	300
rotational speed outer deburring	rev/min	200
electric drive	Hz	50
weight	ca. kg	30
dimensions (mm)	H	225
	W	492
	D	333
order code		OPTIGRAT OG 642



**THE GATES TUBE DIVISION RENTAL PROGRAMME**

ATTRACTIVE RENTAL SOLUTIONS FOR TUBE FITTING ASSEMBLY MACHINERY

Whether you've got some big contracts up ahead, you're expanding your company's capabilities, or you just need to replace your current equipment there are several factors to consider when deciding to invest in new equipment. Both buying and renting have their own pros and cons, some of which are listed below.

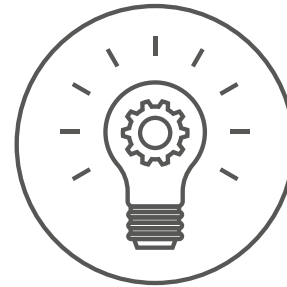

**SOLUTIONS**

Buying	Renting
Better suited for regular or high frequency use	Better suited for short-term use
Higher initial investment cost leads to ownership	Lower investment cost
Less flexible	Equipment can be replaced at any time (= more flexible)
Responsible for maintenance and repair	Less responsibility for repairs and maintenance but damage can result in higher additional charges
Depreciation of equipment	Rental rates can fluctuate + higher logistic costs
No risk of equipment availability	Willingness to compromise on equipment model

In general, buying a machine is recommended when used regularly. However, the Gates tube fitting division understands that not every customer always has as constant need for a specific type of assembly machine. Each project is different and comes with its own challenges. That is why, the Gates tube fittings division offers its customers the option to rent assembly machinery for a certain period in time. The following attractive flat rate hire options are offered.

**Assembly machinery**

- One-time handling charge + price/week
- One-time handling charge + price/per month (period up to 3 months)
- One-time handling charge + price/per month (as of a period of 4 months)

**Assembly tools**

- Weekly rent price
- Monthly rent price

The selection of the assembly tools takes place in dialogue with the Gates tube fitting sales team. Interested to know more about the rental programme and its different options? Please contact your local Gates sales representative.



DRIVEN BY POSSIBILITY™

# 10. ENGINEERING & TECHNICAL DATA

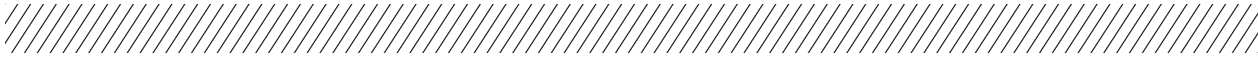

## GATES DS RING - CHARACTERISTICS

The Gates DS ring is the product of extensive research and further development of the well-known EMB cutting ring. Due to the design of the cutting ring geometry, the edges do not cut simultaneously, but one after the other, although the cutting diameter of each cutting edge is exactly equal.

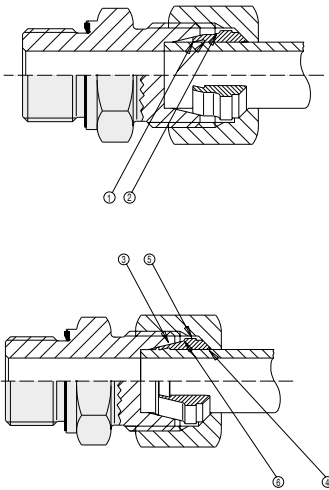

- ① Consequently, the cutting effect is improved and this results in a much greater steadiness during excision at the end of the installation with only slightly more effort.
- ② The DS ring has a limiting surface that signals the end of the installation owing to its location within the body cone. And thereby a force increase is perceptible.
- ③ As both cuttings, as well as the central section, are supported by the cone body, the force is favourably distributed within the cone and this ensures a secure holding function.
- ④ Due to the conical design of the inside end, and the distribution of forces across the cone of the body, the alternating bending stresses that occur are distributed throughout the length of the ring and damped by the cone body and the nut.
- ⑤ The conical surface opposite the cutting edges is smooth, which reduces friction during the assembly, providing a stronger grip. Besides higher stability, the reinforced end of the DS ring reduces friction and takes the pressure off the base of the nut. The required reduction of the cross-section optimises the radial stability and keeps the tube secure.
- ⑥ The stop surface clearly limits over-winding by the bearing at the stud's front surface.

## GATES DSW RING - CHARACTERISTICS

According to current expectations, the connecting points of pipes, installations, etc., should be fitted with soft sealing elements, preferably elastomer materials in order to satisfy the demand for effective sealing. This is particularly important in connections with long-term seals that are subject to extreme stresses in order to protect the environment and resources.

The DSW ring complements the proven range of Gates pipe connections by providing a soft, elastomer-type seal on the pipe side. The ring can be used in standard screw connecting systems with a 24° cone in conformity with DIN 3861, form W, in conjunction with the union nut DIN 3870, form A, or screw connections according to ISO 8434-1. If necessary, the elastomeric sealing ring can be exchanged easily.

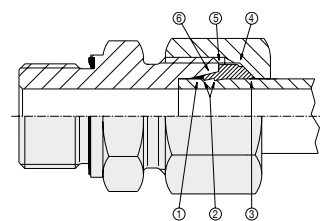

- ① The important primary sealing function is handled by a soft elastomer sealing ring that is integrated in the metal ring for simple installation. It is profiled to match the sealing space, thereby guaranteeing positive fine sealing.
- ② The hold function is performed by a metal ring. This has a special cutting edge shape and a rearward receding cutting edge.
- ③ In order to avoid the unfavourable notch effect on the pipe, the inner contour tapers off into a shallow shoulder end.
- ④ The thick shoulder area, which reduces the surface pressure exerted by the union nut, is followed by a cross-section reduction which contributes to secure pipe clamping.
- ⑤ The wide contact area, which is also the result of the maximum reinforcement of the middle section, ensures that the screw tightening force can be genuinely limited.
- ⑥ The profiled case surface rests against the body cone where it forms an additional metallic seal.

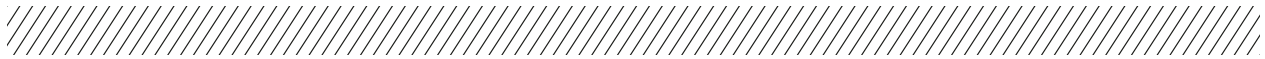

## CUTTING RING FITTINGS - ASSEMBLY WITH VM ADAPTOR

The sequential assembly of cutting ring fittings with subsequent final assembly.

This process is turning angle controlled.

For assemblies using both steel and stainless steel pipes as well as adjustable shaft fittings and pipe-support tubes, the pre-assembly is only to be carried out using the adaptor VM or using other pre-assembly appliances (see chapter "Machinery").

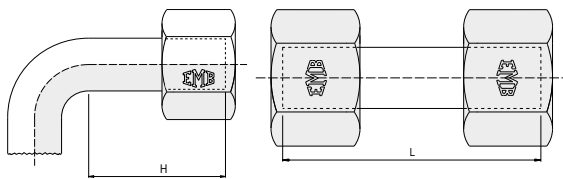

Minimum length (H) of straight tube end for tube bends.

Minimum length (L) for short sections of pipe.

Series	LL				L								S											
tube OD mm	4	5	6	8	6	8	10	12	15	18	22	28	35	42	6	8	10	12	14	16	20	25	30	38
H min	24	25	25	26	31	31	33	33	36	38	42	42	48	48	35	35	37	37	43	43	50	54	58	65
L min	30	32	32	33	39	39	42	42	45	48	53	53	60	60	44	44	47	47	54	54	63	68	73	82

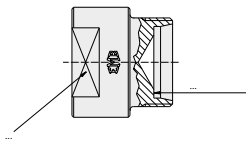

The galvanised Gates cutting-ring fitting is coated with a clear sliding agent, reducing friction and eliminating the need to additionally oil the components. In order to ensure positive assembly, Gates fittings should always be pre-assembled in an oiled pre-assembly adaptor.

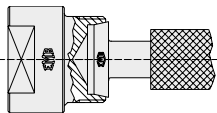

The dimensional stability of the cones will be guaranteed by means of continually checking with a cone gauge.

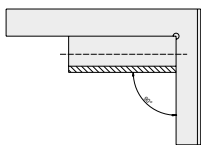

Pipes have to be sawn off rectangularly. Do not use a pipe cutter!

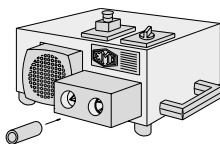

Clean the pipe inside and outside.

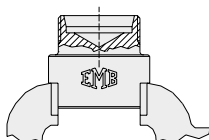

Clamp the pre-mounting socket in a vice, having previously selected the appropriate series and pipe dimensions.

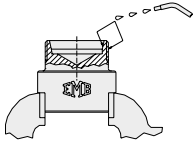

Oil pre-mounting socket - do not grease. When using non-rusting materials it is necessary to lubricate the cutting ring and the nut, as well as the VM, by using a special lubricating agent. For this purpose we recommend Gates lubricating paste. Do not use commercially available lubricating oils!

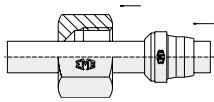

Move screwing components over the pipe end as illustrated.

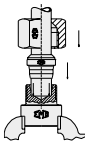

Position pipe in the pre-mounting socket and press firmly against the stop in the inner cone.

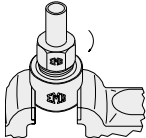

Tighten the fitting nut until the pipe no longer turns in the assembly. The cutting ring then locks on to the pipe.

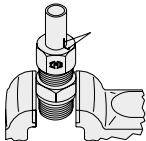

A mark on the nut indicates the turning direction.

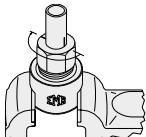

Tighten the fitting nut by half a turn. The cutting ring will uniformly cut into the pipe.

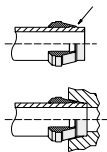

After pre-assembly, check whether a visible flare is present before the first cut. Use a partially slotted series connecting piece for this purpose. The contact face of the pre-assembled pipe must rest against the pipe stop of the screw union connection.

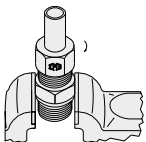

Insert the pre-assembled tube into the assembly socket and turn it approximately 1/2 turn, beyond the point where the torque rise makes itself felt.

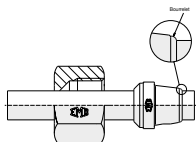

After the connection has been tightened, release it again. Check whether the collar bulge fills the space in front of the cutting edge. The ring can rotate but cannot be moved on its axis.



Each time the connection is disconnected, the union nut must be retightened firmly (similar to final assembly).  
Use a spanner to counter the screw connection!





## CUTTING RING FITTINGS - ASSEMBLY

### Assembly in the screw socket and direct assembly for repair purposes

Pipes made of non-rusting steel, pipe-supports, tube fittings and adjustable shaft screw fittings must be assembled using the pre-assembly adaptor (VM) or using other assembly appliances (see chapter "Machinery").

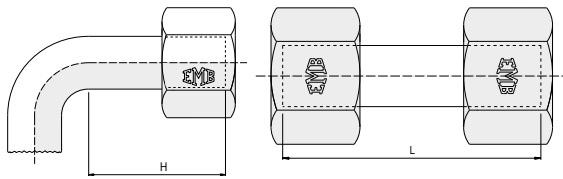

Minimum length (H) of straight tube end for tube bends.

Minimum length (L) for short sections of pipe.

Series	LL				L										S									
tube OD mm	4	5	6	8	6	8	10	12	15	18	22	28	35	42	6	8	10	12	14	16	20	25	30	38
H min	24	25	25	26	31	31	33	33	36	38	42	42	48	48	35	35	37	37	43	43	50	54	58	65
L min	30	32	32	33	39	39	42	42	45	48	53	53	60	60	44	44	47	47	54	54	63	68	73	82

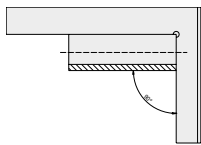

Pipes have to be sawn off rectangularly. Do not use a pipe cutter!

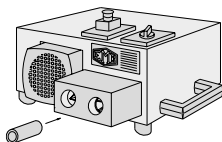

Clean the pipe inside and outside.

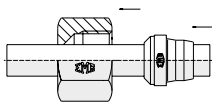

Move screwing components over the pipe end as illustrated.

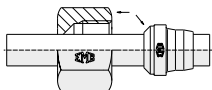

The collar of the cutting ring must face the fitting nut - otherwise a faulty assembly will be the result.

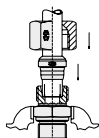

Position the pipe in the pre-mounting socket and press firmly against the stop in the inner cone.

# ENGINEERING & TECHNICAL DATA

SELECTING THE CORRECT TUBE FITTING

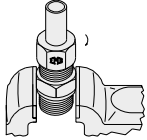

Tighten the fitting nut until the pipe no longer turns in the assembly. The cutting ring then locks on to the pipe.

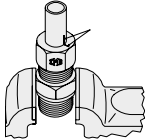

A mark on the nut indicates the turning direction.

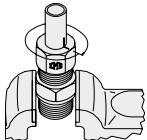

Tighten the fitting nut by one turn. The cutting ring will evenly cut into the pipe and clearly raise and remove material in front of its cutting edge.

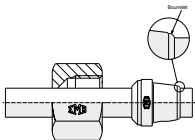

After the connection has been tightened, release it again. Check whether the collar bulge fills the space in front of the cutting edge. The ring can rotate but cannot be moved on its axis.



Each time the fitting is disassembled the nut must be retightened firmly (similar to final assembly). Use a spanner to counter the screw connection!

When using a series-type screw socket, make sure that every pipe end is repositioned within the same inner cone in which the pre-mounting process takes place.

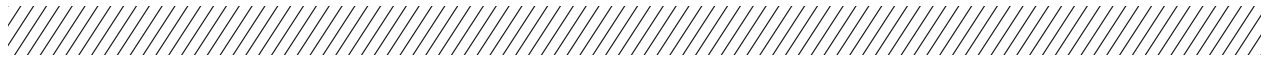

## ADJUSTABLE FITTINGS WITH LOCKNUT - ASSEMBLY

Fittings without support ring for stud ports  
ISO 6149 or UN/UNF.

Fittings with support ring for stud ports  
Whitworth or metric parallel thread with wide  
or small spot face.

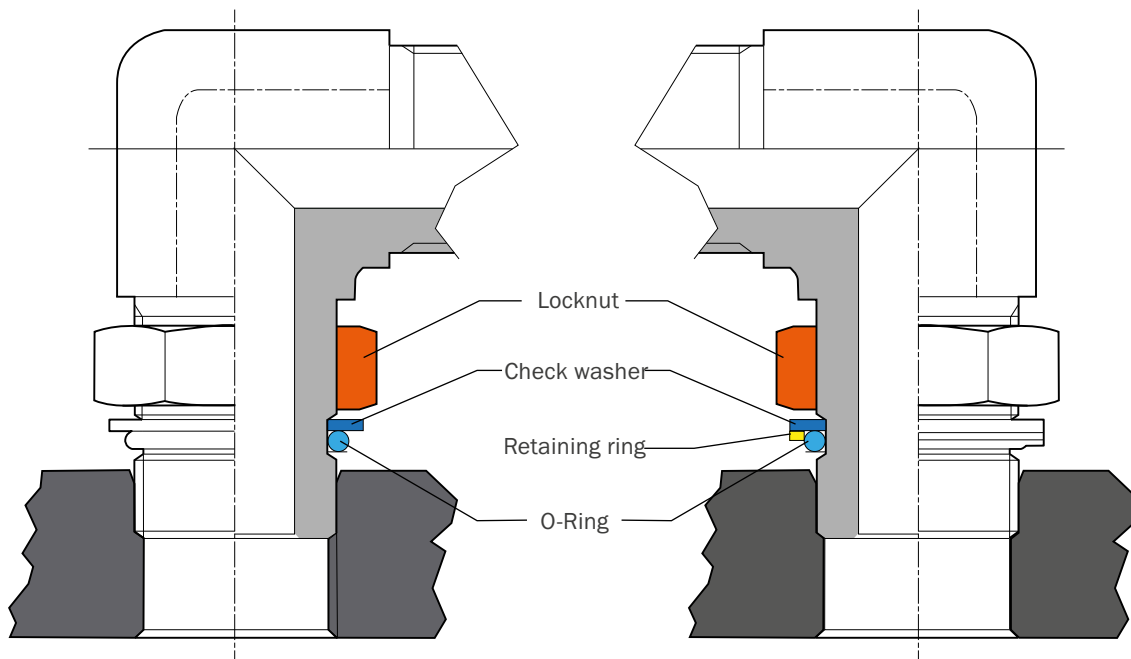

1. Unlock nut as far as possible, check O-ring, washer and retaining ring. These should be in their proper position at the locknut. Oil the O-ring.
2. Screw fitting by hand into the thread port until the washer or retaining ring contact the face of the port.
3. Push fitting in the required position and tighten locknut.
4. Hold fitting in wanted position and tighten locknut.



## GATES CUTTING RING TYPE PIPE SCREW JOINTS

### Standardisation

Deriving from different standards, pipe screw joints and accessories have been improved by constant developments to achieve the present level of quality. This level is in accordance with the standards DIN 2353/ISO 8434-1 and -4. The majority of Gates parts and patterns exceed the standard pressure ratings.

Gates has more than 60 years of experience in manufacturing precision parts, thereby enabling us – together with the certified quality assurance – to ensure the utmost reliability of the products.

Performance and operational reliability of the Gates fitting can only be guaranteed if both Gates components are used and Gates assembly instructions are adhered. Further technical development reserved.

### Materials

The Gates pipe screw joints included in this catalogue are normally manufactured from drawn or forged steel:

- Gates pipe screw joints of steel.
- Gates pipe screw joints of stainless steels – 6CrNiMoTi17122, 1.4571.

### Compressive strength and thermal endurance

The pressure specifications given in our catalogue relate to steel fittings with a static load at a temperature of up to + 120 °C and refer to the rated pressure PN (nominal pressure) according to DIN EN 764-1. PN has a safety factor of 4 (DIN 3859).

Unless otherwise indicated, the pressures mentioned in brackets represent the EMB maximum bursting pressure.

PB is the overpressure of the operating pressure according to DIN EN 764-1. Unless otherwise indicated, the safety factor for PB is 2,5.

### Pressure range

Series	LL			L										S									
	4	6	8	6	8	10	12	15	18	22	28	35	42	6	8	10	12	14	16	20	25	30	38
K1	100			500			400			250				800			630			400			
K2	100			250			160			100				630			400			250			
K3*	100			315			160			630				400			315						

\* Pressure drop to be considered.

K1 - Steel // DS-Ring, DSW-Ring.

K2 - Stainless Steel // S-Ring.

K3 - Stainless Steel // DS-Ring, DSW-Ring.

### Working temperature for fittings

Steel: -40 °C up to +120 °C (DIN 3859).

Stainless steel: -60 °C up to +400 °C (DIN EN 10088-3).

Consider below information "Reduction of pressure".

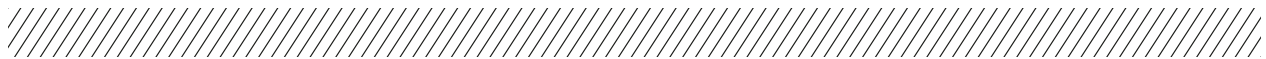

## WORKING TEMPERATURE FOR SEALINGS

NBR (e.g. Perbunan\*): -35 °C up to +100 °C.

FKM (e.g. Viton\*\*): -25 °C up to +200 °C.

PTFE (e.g. Teflon\*\*): -60 °C up to +200 °C.

The temperatures are recommendations only. These can be influenced by the operating medium. To define the use of different materials (components or joints), take the smallest respective temperatures limits as a starting point.

## TEMPERATURE DEPENDENT PRESSURE RATING REDUCTION

A reduction of pressure is necessary when operating at various temperatures.

Material fitting	Temperature range	Reduction of pressure
Steel	- 40 °C up to + 120 °C	no
1,4571	- 60 °C up to + 20 °C	no
1,4571	+ 50 °C	4 %
1,4571	+ 100 °C	11 %
1,4571	+ 200 °C	20 %
1,4571	+ 300 °C	29 %
1,4571	+ 400 °C	33 %

For other tubes and fitting materials, the tubes have to be tested separately on both the approved temperature range and the necessary reduction of pressure.

When using male stud fittings, additional pressure reductions may apply. This is caused by both the counter material which the part is screwed into and the sealing material.

To make use of the maximum operating pressure, we recommend male stud fittings with WD sealing (soft seal). Depending on the counter material, an alternative sealing material may be necessary.

Further different circumstances should be considered. Approved pressures, security factors, temperatures as well as standards, instructions or registrations may influence the pressure calculation.

Rated pressure (PN) and operating pressure (PB) are the maximum permissible working pressures, including any pressure peaks. The pressure has to be adjusted in accordance to the temperature variations. The pressure and security details apply only when using original Gates parts as well as following the Gates assembly instructions. Perfect clamping of the tube system is important in order to reduce vibration and to prevent subsequent damage.

## SURFACE

To provide durable surface protection, Gates cutting ring type pipe screw joints are coated with Zink Nickel. Other coatings can be delivered upon request.

## STORAGE

For parts with soft sealing, please follow instructions and pay attention to comments according to DIN 7716.

\* Registered trademark of BAYER AG.  
\*\* Registered trademark of DU PONT.



## ORDER CODE LOGIC, DELIVERY, AND PACKAGING

The order symbols given in the catalogue refer to steel parts. They apply to complete assemblies comprising socket, nut and Gates cutting ring. For ordering screw joint sockets separately, an "X" has to be added to the order symbol as prefix.

### Example screw joints:

- |                                  |             |
|----------------------------------|-------------|
| ▪ Complete with S ring           | A 4-RLL     |
| ▪ Complete with DS ring          | DS-A 25-RS  |
| ▪ Socket without DS ring and nut | XA 25-RS    |
| ▪ Complete with DSW ring         | DSW-A 25-RS |

Where materials or surfaces other than standards are desired, the respective symbols will be added to follow the catalogue order symbol.

### Example screw joints:

- |  |                          |
|--|--------------------------|
| ▪ Complete Form A/60°, stainless steel | DS-A 25-RS/Form A/1.4571 |
| ▪ Screw joint with Viton sealing       | DS-A 25-RS/WD/VIT        |

Standard pipe screw joints are available at short notice and are supplied in cardboard boxes with additional product protection where necessary. The packing condition follows principles for optimised facilitation of storage and guaranteed protection against contamination.

Quantities per package unit are given in the price list. Full package orders are appreciated.

If smaller quantities are required, you may contact your Gates service partner.



## STUD THREADS AND PORTS FOR PIPE FITTINGS

**BSP parallel DIN-ISO 228**

**BSP taper DIN 3858**

**Metric parallel DIN 13**

**Metric taper DIN 158**

Soft sealing and O-ring sealing NBR (Perbunan\*); FKM upon request (Viton\*\*).

Stud thread form A	Stud thread form B	Stud thread form E	Stud thread form SBE	Stud thread form C
DIN 3852 Part 1+2	DIN 3852 Part 1+2	DIN 3852 Part 11	EMB	DIN 3852 Part 1+2
Sealing by sealing ring DIN 7603	Sealing by sealing shoulder	Sealing by soft ring	Sealing by EDE ring or DKA	Sealing by conical thread

Port form X	Port form X	Port form X	Port form X	Port form Z
DIN 3852 Part 1+2 for parallel stud threads	DIN 3852 Part 1+2 for parallel stud threads	DIN 3852 Part 1+2 for parallel stud threads	DIN 3852 Part 1+2 for parallel stud threads	DIN 3852 Part 1+2 for conical stud threads

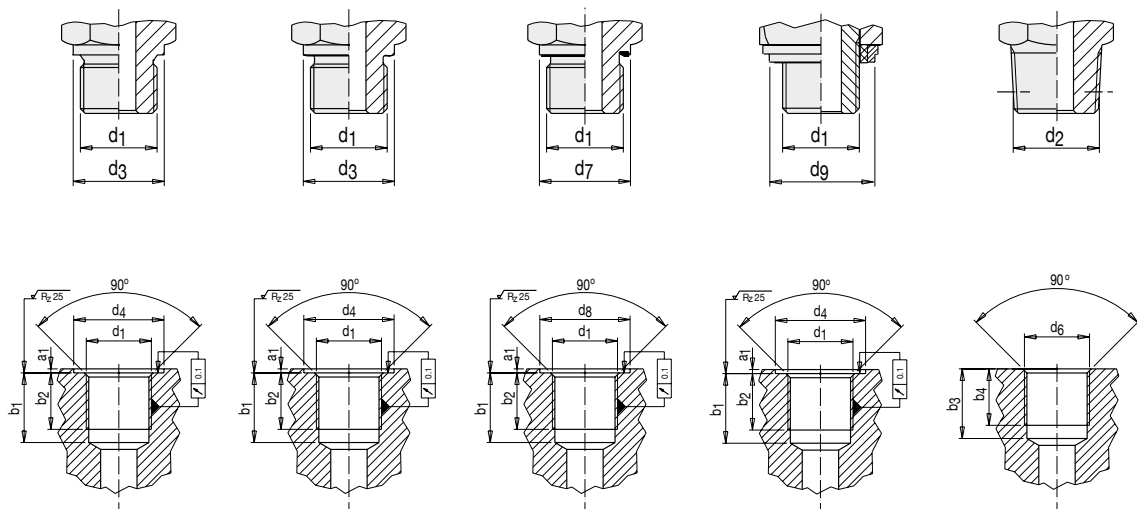

\* Registered trademark of BAYER AG.  
 \*\* Registered trademark of DU PONT.

# ENGINEERING & TECHNICAL DATA

SELECTING THE CORRECT TUBE FITTING



Pipe OD mm	Series	BSP												Metric															
		d <sub>1</sub> **	d <sub>4</sub>	d <sub>3</sub>	d <sub>8</sub>	d <sub>7</sub>	d <sub>9</sub>	a <sub>1</sub>	b <sub>1</sub>	b <sub>2</sub>	d <sub>2</sub>	d <sub>6</sub>	b <sub>3</sub>	b <sub>4</sub>	d <sub>1</sub>	d <sub>4</sub>	d <sub>3</sub>	d <sub>8</sub>	d <sub>7</sub>	d <sub>9</sub>	a <sub>1</sub>	b <sub>1</sub>	b <sub>2</sub>	d <sub>2</sub>	b <sub>3</sub>	b <sub>4</sub>			
4	J	G 1/8"A	15	14				1	13	8	R 1/8" taper	G 1/8"	9.5	5.5												M 8x1 taper	10	5.5	
																											M 8x1 taper	10	5.5
		G 1/8"A	15	14				1	13	8	R 1/8" taper	G 1/8"	9.5	5.5												M 10x1 taper	10	5.5	
		G 1/8"A	15	14				1	13	8	R 1/8" taper	G 1/8"	9.5	5.5												M 10x1 taper	10	5.5	
6	J	G 1/8"A	15	14	15	13.9	14.9	1	13	8	R 1/8" taper	G 1/8"	9.5	5.5	M 10x1	15	14	15	13.9	14.9	1	13.5	8		M 10x1 taper	10	5.5		
		G 1/4"A	19	18	20*	18.9*	18.9	1.5	18.5	12	R 1/4" taper	G 1/4"	13.5	8.5	M 12x1.5	18	17	18	16.9	16.9	1.5	18.5	12		M 12x1.5 taper	13.5	8.5		
		G 1/4"A	19	18	20*	18.9*	18.9	1.5	18.5	12	R 1/4" taper	G 1/4"	13.5	8.5	M 14x1.5	20	19	20	18.9	18.9	1.5	18.5	12		M 14x1.5 taper	13.5	8.5		
		G 3/8"A	23	22	23	21.9	21.9	2	18.5	12	R 3/8" taper	G 3/8"	13.5	8.5	M 16x1.5	22	21	23*	21.9*	21.9	1.5	18.5	12		M 16x1.5 taper	13.5	8.5		
		G 1/2"A	27	26	28*	26.9*	26.9	2.5	22	14	R 1/2" taper	G 1/2"	16.5	10.5	M 18x1.5	24	23	25*	23.9*	23.9	2	18.5	12		M 18x1.5 taper	13.5	8.5		
		G 1/2"A	27	26	28*	26.9*	26.9	2.5	22	14	R 1/2" taper	G 1/2"	16.5	10.5	M 22x1.5	28	27	28	26.9	26.9	2.5	20.5	14		M 22x1.5 taper	15.5	10.5		
		G 3/4"A	33	32	33	31.9	32.9	2.5	24	16	R 3/4" taper	G 3/4"	19	13	M 26x1.5	32	31	33*	31.9*	31.9	2.5	22.5	16						
		G 1"A	40	39	41*	39.9*	39.9	2.5	27	18	R 1" taper	G 1"	23	16	M 33x2	40	39	41*	39.9*	39.9	2.5	26	18						
		G 1 1/4"A	50	49	51*	49.9*	49.9	2.5	29	20	R 1 1/4" taper	G 1 1/4"	24	17	M 42x2	50	49	51*	49.9*	49.9	2.5	28	20						
		G 1 1/2"A	56	55	56	54.9	55.9	2.5	31	22	R 1 1/2" taper	G 1 1/2"	24	17	M 48x2	56	55	56	54.9	55.9	2.5	30	22						
		6	S	G 1/4"A	19	18	20*	18.9*	18.9	1.5	18.5	12	R 1/4" taper	G 1/4"	13.5	8.5	M 12x1.5	18	17	18	16.9	16.9	1.5	18.5	12		M 12x1.5 taper	13.5	8.5
				G 1/4"A	19	18	20*	18.9*	18.9	1.5	18.5	12	R 1/4" taper	G 1/4"	13.5	8.5	M 14x1.5	20	19	20	18.9	18.9	1.5	18.5	12		M 14x1.5 taper	13.5	8.5
G 3/8"A	23			22	23	21.9	21.9	2	18.5	12	R 3/8" taper	G 3/8"	13.5	8.5	M 16x1.5	22	21	23*	21.9*	21.9	1.5	18.5	12		M 16x1.5 taper	13.5	8.5		
G 3/8"A	23			22	23	21.9	21.9	2	18.5	12	R 3/8" taper	G 3/8"	13.5	8.5	M 18x1.5	24	23	25*	23.9*	23.9	2	18.5	12		M 18x1.5 taper	13.5	8.5		
G 1/2"A	27			26	28*	26.9*	26.9	2.5	22	14	R 1/2" taper	G 1/2"	16.5	10.5	M 20x1.5	26	25	27*	25.9*	25.9	2	20.5	14		M 20x1.5 taper	15.5	10.5		
G 1/2"A	27			26	28*	26.9*	26.9	2.5	22	14	R 1/2" taper	G 1/2"	16.5	10.5	M 22x1.5	28	27	28	26.9	26.9	2.5	20.5	14		M 22x1.5 taper	15.5	10.5		
G 3/4"A	33			32	33	31.9	32.9	2.5	24	16					M 27x2	33	32	33	31.9	32.9	2.5	24	16						
G 1"A	40			39	41*	39.9*	39.9	2.5	27	18					M 33x2	40	39	41*	39.9*	39.9	2.5	26	18						
30	S	G 1 1/4"A	50	49	51*	49.9*	49.9	2.5	29	20				M 42x2	50	49	51*	49.9*	49.9	2.5	28	20							
		G 1 1/2"A	56	55	56	54.9	55.9	2.5	31	22				M 48x2	56	55	56	54.9	55.9	2.5	30	22							

\* Deviating from DIN 3852.

\*\* For female thread "A" does not apply.



# ENGINEERING & TECHNICAL DATA

SELECTING THE CORRECT TUBE FITTING



## Metric parallel DIN ISO 6149-1/-2/-3

## UNF / UN parallel ISO 11926-1/-2/-3

## NPT taper ANSI / ASME B1.20.1-1983

O-ring sealing NBR (Perbunan\*); FKM upon request (Viton\*\*).

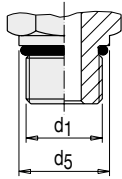

### Stud

DIN ISO 6149-2+3.

Sealing by O-ring.

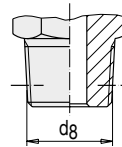

### Stud thread NPT

ANSI / ASME B1.20.1-1983.

Sealing by conical thread.

### Stud threads UNF and UN-2 A

ISO 11926-2+3.

Sealing by O-ring.

d1	d5	d2	d3	d4	a1	a2	b1	b2	
<b>UNF/UN</b>	<b>- 0.4</b>	<b>± 0.05</b>		<b>min.</b>	<b>max.</b>	<b>0.4</b>	<b>min.</b>	<b>min.</b>	<b>± 1°</b>
7/16 - 20 UNF	14	12.45	15	21	1.6	2.4	14	11.5	12°
9/16 - 18 UNF	17	15.70	18	25	1.6	2.5	15.5	12.7	12°
3/4 - 16 UNF	22	20.65	23	30	2.4	2.5	17.5	14.3	15°
7/8 - 14 UNF	27	24.00	28	34	2.4	2.5	20	16.7	15°
11/16 - 12 UN	32	29.20	33	41	2.4	3.3	23	19.0	15°
15/16 - 12 UN	41	35.55	42	49	3.2	3.3	23	19.0	15°
15/8 - 12 UN	50	43.55	51	58	3.2	3.3	23	19.0	15°

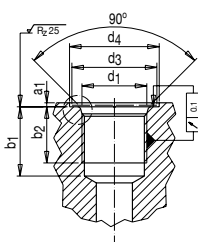

### Port

DIN ISO 6149-1.

For O-ring sealing.

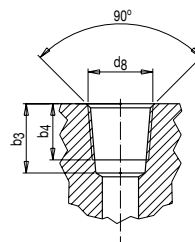

### Port NPT

ANSI / ASME B1.20.1-1983.

For conical thread.

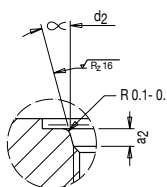

### Port UNF and UN-2 B

ISO 11926-1.

For O-ring sealing.

\* Registered trademark of BAYER AG.  
 \*\* Registered trademark of DU PONT.

# ENGINEERING & TECHNICAL DATA

SELECTING THE CORRECT TUBE FITTING



Pipe OD mm	Series	Metric										NPT		
		d <sub>1</sub>	d <sub>5</sub>	d <sub>2</sub>	d <sub>3</sub>	d <sub>4</sub> *	a <sub>1</sub>	a <sub>2</sub>	b <sub>1</sub>	b <sub>2</sub>	a	d <sub>6</sub>	b <sub>3</sub>	b <sub>4</sub>
			-0,4	0,1	min.	min.	max.	0,4	min.	min.	w 1°		min.	min.
4	J	M 8 x 1	12	9.1	12.5	14	1	1.6	11.5	10	12	1/8"	12	10
5		--	--	--	--	--	--	--	--	--	--	--	--	--
6		M 10 x 1	14	11.1	14.5	16	1	1.6	11.5	10	12	1/8"	12	10
8		M 10 x 1	14	11.1	14.5	16	1	1.6	11.5	10	12	1/8"	12	10
6	J	M 10 x 1	14	11.1	14.5	16	1	1.6	11.5	10	12	1/8"	12	10
8		M 12 x 1.5	17	13.8	17.5	19	1.5	2.4	14	11.5	15	1/4"	17	14
10		M 14 x 1.5	19	15.8	19.5	21	1.5	2.4	14	11.5	15	1/4"	17	14
12		M 16 x 1.5	22	17.8	22.5	24	1.5	2.4	15.5	13	15	3/8"	17	14
15		M 18 x 1.5	24	19.8	24.5	26	2	2.4	17	14.5	15	1/2"	21	17
18		M 22 x 1.5	27	23.8	27.5	29	2	2.4	18	15.5	15	1/2"	21	17
22		M 27 x 2	32	29.4	32.5	34	2	3.1	22	19	15	3/4"	21	17
28		M 33 x 2	41	35.4	41.5	43	2.5	3.1	22	19	15	1"	26	21
35		M 42 x 2	50	44.4	50.5	52	2.5	3.1	22.5	19.5	15	1 1/4"	29	24
42		M 48 x 2	55	50.4	55.5	57	2.5	3.1	25	22	15	1 1/2"	29	24
6	S	M 12 x 1.5	17	13.8	17.5	19	1.5	2.4	14	11.5	15	1/4"	17	14
8		M 14 x 1.5	19	15.8	19.5	21	1.5	2.4	14	11.5	15	1/4"	17	14
10		M 16 x 1.5	22	17.8	22.5	24	1.5	2.4	15.5	13	15	3/8"	17	14
12		M 18 x 1.5	24	19.8	24.5	26	2	2.4	17	14.5	15	3/8"	17	14
14		M 20 x 1.5	27	21.8	27.5	29	2	2.4	17	14.5	15	1/2"	21	17
16		M 22 x 1.5	27	23.8	27.5	29	2	2.4	18	15.5	15	1/2"	21	17
20		M 27 x 2	32	29.4	32.5	34	2	3.1	22	19	15	3/4"	21	17
25		M 33 x 2	41	35.4	41.5	43	2.5	3.1	22	19	15	1"	26	21
30		M 42 x 2	50	44.4	50.5	52	2.5	3.1	22.5	19.5	15	1 1/4"	29	24
38		M 48 x 2	55	50.4	55.5	57	2.5	3.1	25	22	15	1 1/2"	29	24

\* Type without groove for identification.



## TIGHTENING TORQUES MA FOR STUDS

Torques for studs with metal seal, form B, DIN 3852 or with soft sealing (WD) to avoid leaking.

### Sealing of conical thread

Conical threads are not self-sealing. To achieve leak-free sealing, an additional sealing medium is necessary. A well-established sealing medium is a PTFE-tape (e. g. Teflon\*).

### Note:

The quoted figures relate to fittings out of steel (galvanised), to counter parts made of steel, and studs with soft sealing. For the type RI, the tightening torques for series "S" are to be used.

### Tightening torques: pipe thread / metric thread

Series	Pipe OD	Pipe thread	Screw in thread				
			Form B MA (Nm)	with WD MA (Nm)	metric thread ISO	Form B MA (Nm)	with WD MA (Nm)
L	6	G 1/8 A	18	18	M 10 x 1.0	18	18
L	8	G 1/4 A	35	35	M 12 x 1.5	30	25
L	10	G 1/4 A	35	35	M 14 x 1.5	45	45
L	12	G 3/8 A	70	70	M 16 x 1.5	65	55
L	15	G 1/2 A	140	90	M 18 x 1.5	80	70
L	18	G 1/2 A	100	90	M 22 x 1.5	140	125
L	22	G 3/4 A	180	180	M 26 x 1.5	190	180
L	28	G 1 A	330	310	M 33 x 2.0	340	310
L	35	G 1 1/4 A	540	450	M 42 x 2.0	500	450
L	42	G 1 1/2 A	630	540	M 48 x 2.0	630	540
S	6	G 1/4 A	55	55	M 12 x 1.5	35	35
S	8	G 1/4 A	55	55	M 14 x 1.5	55	55
S	10	G 3/8 A	90	80	M 16 x 1.5	70	70
S	12	G 3/8 A	90	80	M 18 x 1.5	110	90
S	14	G 1/2 A	150	115	M 20 x 1.5	150	125
S	16	G 1/2 A	130	115	M 22 x 1.5	170	135
S	20	G 3/4 A	270	180	M 27 x 2.0	270	180
S	25	G 1 A	340	310	M 33 x 2.0	410	310
S	30	G 1 1/4 A	540	450	M 42 x 2.0	540	450
S	38	G 1 1/2 A	700	540	M 48 x 2.0	700	540

\*Registered trademark of DU PONT.



## PIPES – DIMENSIONS AND CHARACTERISTICS

We recommend the use of seamless precision steel tubes with dimensions to DIN 10305, part 4, material conforming St 37.4 (to DIN 10277), NBK.

Outer dia	Wall thickness	Sectional area of flow approx.	Weight	Calculated pressure
mm	mm	cm <sup>2</sup>	kg/m	bar
4	0.75	0.049	0.060	409
4	1.00	0.031	0.074	522
6	1.00	0.130	0.123	389
6	1.50	0.071	0.166	549
6	2.00	0.031	0.197	692
6	2.25	0.017	0.208	757
8	1.00	0.280	0.173	333
8	1.50	0.200	0.240	431
8	2.00	0.130	0.296	549
8	2.50	0.071	0.339	658
10	1.00	0.500	0.222	282
10	1.50	0.380	0.314	373
10	2.00	0.280	0.395	478
10	2.50	0.190	0.462	576
10	3.00	0.130	0.518	666
12	1.00*	0.790	0.271	235
12	1.50	0.640	0.389	353
12	2.00	0.500	0.493	409
12	2.50	0.380	0.586	495
12	3.00	0.280	0.606	576
12	3.50	0.190	0.734	651
15	1.50	1.130	0.499	282
15	2.00	0.950	0.641	376
15	2.50	0.780	0.771	409
15	3.00	0.640	0.888	478
16	2.00	1.130	0.691	353
16	2.50	0.950	0.832	386
16	3.00	0.790	0.962	452
18	1.50*	1.760	0.610	235
18	2.00	1.530	0.789	313
18	2.50	1.330	0.956	392
18	3.00	1.130	1.110	409

Outer dia	Wall thickness	Sectional area of flow approx.	Weight	Calculated pressure
mm	mm	cm <sup>2</sup>	kg/m	bar
20	2.50	1.770	1.080	353
20	3.00	1.540	1.260	373
20	3.50	1.330	1.424	426
20	4.00	1.130	1.578	478
22	2.00*	2.550	0.986	256
22	2.50	2.270	1.202	320
22	3.00	2.010	1.406	385
25	2.00*	3.460	1.134	226
25	2.50	3.140	1.387	282
25	3.00	2.830	1.628	338
25	4.00	2.260	2.072	394
25	4.50	2.010	2.275	437
25	5.00	1.760	2.466	478
28	2.00*	4.520	1.282	201
28	2.50	4.150	1.572	252
28	3.00	3.800	1.850	302
28	4.00	3.140	2.368	403
28	5.00	2.540	2.836	434
30	3.00	4.520	2.000	282
30	4.00	3.800	2.570	376
30	5.00	3.140	3.080	409
35	2.00*	7.540	1.630	161
35	2.50	7.060	2.000	201
35	3.00	6.600	2.370	242
35	4.00	5.720	3.060	322
35	5.00	4.900	3.690	403
35	6.00	4.150	4.290	419
38	4.00	7.070	3.350	297
38	5.00	6.160	4.070	371
38	6.00	5.310	4.740	390
38	7.00	4.520	5.350	446
42	3.00	10.180	2.890	201
42	4.00	9.080	3.750	269

When thin-walled tubes are subject to severe strain, parallel sleeves are recommended.

Calculated pressures have been determined in conforming to DIN 2413, scope of application is for primary static load at temperatures up to +120 °C.

### Characteristic values

Yield point: 235 N/mm<sup>2</sup>.

Safety factor: 1.5.

Permissible variation in wall thickness: DIN 2391/sheet 1.

Calculated to DIN 2413/III for a ratio of diameters of  $u = OD/ID > 1.35$ .

Tubes made of stainless steel (e.g. 1.4571) to be cold-drawn seamless and heat-treated scale - free to DIN EN 10216-5-X6 CrNiMoTi17-12-2 - CFD with tolerances to DIN EN ISO 1127.

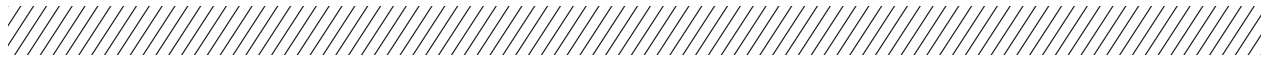

## TABLE FOR THE APPLICATION OF REINFORCING SLEEVES

Wall thickness	Steel tubes St 37.4 and 1.4571																						
	4																						
3.5																							
3																							
2.5																							
2																							
1.5																							
1																							
0.75																							
0.5																							
Pipe OD	4	6	8	6	8	10	15	15	18	22	28	35	42	6	8	10	12	14	16	20	25	30	38
Series	LL			L										S									

Wall thickness	For soft metal tubes																						
	4																						
3.5																							
3																							
2.5																							
2																							
1.5																							
1																							
0.75																							
0.5																							
Pipe OD	4	6	8	6	8	10	15	15	18	22	28	35	42	6	8	10	12	14	16	20	25	30	38
Series	LL			L										S									

● VSH is always required.

○ VSH is recommended; particularly in case of frequent loosening and in connection with heavily loaded lines (vibrations).

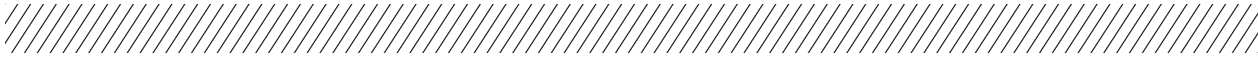

## PORT CONNECTIONS AND SEALS FOR TEST FITTINGS

Form A			
G	d <sub>1</sub>	t <sub>1</sub>	t <sub>2</sub>
M8x1	9.5+0.1	11	15.5
M10x1	11.5+0.1	12	16.5

Form B				
G	d <sub>1</sub>	t <sub>1</sub>	t <sub>2</sub>	a
M14x1.5	20	12	18.5	1
M16x1.5	22	12	18.5	1
G1/4	19	12	18.5	1
G3/8	23	12	18.5	1.5

Form C				
G	d <sub>1</sub>	t <sub>1</sub>	t <sub>2</sub>	a
M12x1.5	18	12	18.5	1
G1/8	15	8	13	1
G1/4	19	12	18.5	1

Form D			
G	type	t <sub>1</sub>	t <sub>2</sub>
R1/8	taper	5.5	9.5
R1/4	taper	8.5	13.5
1/8	NPT	9	13.5
1/4	NPT	12	18.5

Form E						
G	type	d <sub>1</sub>	d <sub>2</sub>	t <sub>1</sub>	t <sub>2</sub>	a
9/16-24	UNF	9.1	17	10	12	1.9
7/16-20	UNF	12.4	21	11.5	14	2.4
1/2-20	UNF	14	23	11.5	14	2.4
9/16-18	UNF	15.6	25	12.7	15.5	2.5

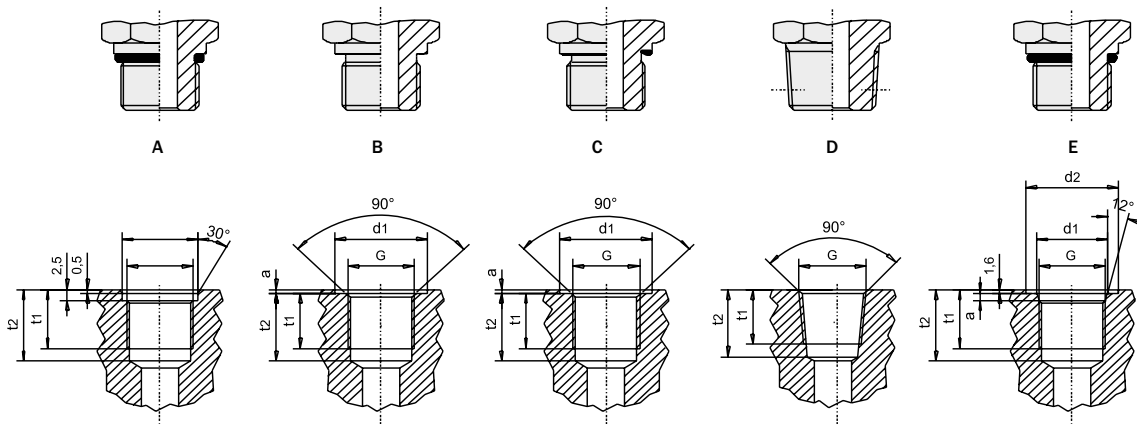



## TEST HOSES TECHNICAL DATA

Order code		A	B	C
Nominal bore		DN2	DN2	DN4
max. working pressure	bar	400	630	340
burst pressure	bar	1100	1900	850
testing pressure	bar	600	950	570
pressure rating at 0°C	bar	488	768	463
pressure rating at 30°C	bar	440	693	418
pressure rating at 50°C	bar	400	630	380
pressure rating at 80°C	bar	344	542	327
pressure rating at 100°C	bar	308	485	293
working temperature	°C	-30 to 100 momentary		
inside diameter	mm	2	2	4
outside diameter	mm	5	5	8.6
bending radius	mm	20	20	40
max. coil length	m	30	30	60
weight/meter	g	16	16	42
inner and outer tube wall reinforcement		PA	PA	PA
		synthetic fibre		

## REDUCING FITTINGS - EXAMPLES

The great variety of reducers can be restricted by the use of standard screw joints. The desired combination can be provided in short-notice cases of demand or in cases of small quantities.

### Straight male thread screw joint

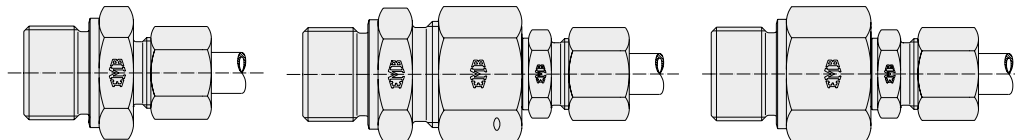

Pipe outside diameter: 14 mm  
 Male thread: R 1"  
 Series: S

Combination possible from:

Straight male thread screw joint with male thread R 1" (for instance A 25-RS) and reducing screw joint RSDKO 25/14. Threaded reducing socket RI 1"-1/2" and straight male thread screw joint A 14-RS.

### Straight screw joint

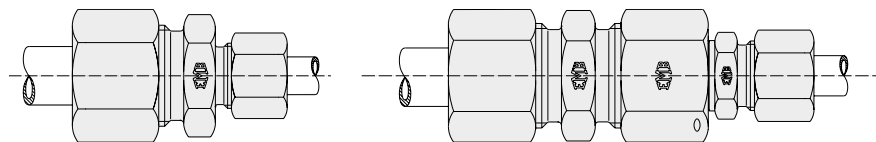

1st pipe outside diameter: 30 mm  
 2nd pipe outside diameter: 20 mm  
 Series: S

Combination possible from:

Straight screw joint E 30-S.  
 Reducing screw joint RSDKO 30/20.



## L-shaped male thread screw joint

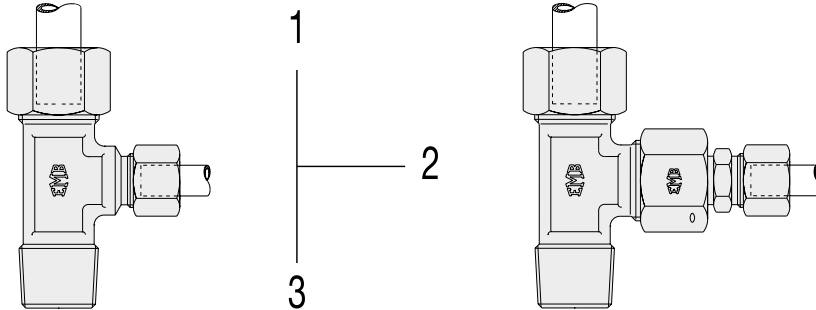

1st pipe outside diameter: 16 mm  
 2nd pipe outside diameter: 10 mm  
 Male thread: NPT  
 Series: S  
 Order pattern: 1-2-3

Combination possible from:  
 L-shaped male thread screw joint.  
 D 16-S/NPT and reducing screw joint RSDKO 16/10.

## T-screw joint

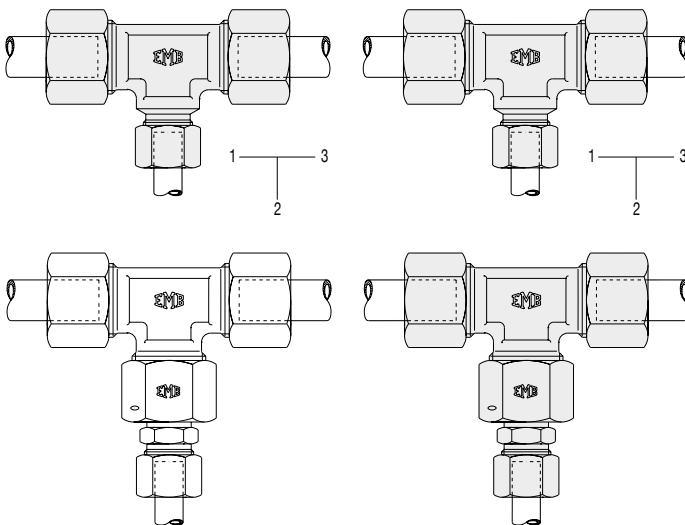

1st pipe outside diameter: 12 mm  
 2nd pipe outside diameter: 8 mm  
 3rd pipe outside diameter: 12 mm  
 Series: S  
 Order pattern: 1-2-3

Combination possible from:  
 T-screw joint G 12-S.  
 Reducing screw joint RS 12/8.

Similarly it is possible to provide reducing screw joint assemblies also in other configurations and combinations.

Further combinations are offered by using the straight male thread socket VADKO.





## WELDING NIPPLE TYPE SCREW JOINTS - TECHNIQUE

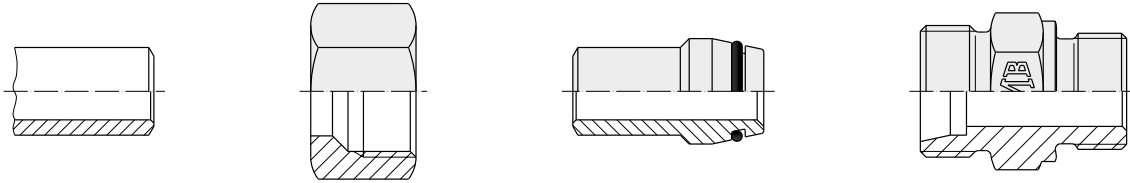

In particularly intricate working conditions Gates welding nipple type screw joints will come to use with:

- Extreme vibrations
- Pulsating loads
- Very heavy pressure surges
- Extreme temperatures and fluctuations in temperature
- In systems where outages lead to high cost

Welding nipples can be easily complemented using solder less pipe screw joints according to DIN 2352/ISO 8434-1. The cutting ring is removed and the welding nipple is fitted in its place.

The working-pressure (PB) of complete welding nipple fittings is determined by the component showing the lowest pressure (pipe, welding-nipple, fittings).

The oiled steel welding cone SNO corresponds to DIN 3865, form A.

Steel based welding nipples can be welded appropriately with common methods. The choice of the welding additive in accordance to DIN 8556 has to be chosen by considering the welding method and the specific application.

## WELDING NIPPLE TYPE SCREW JOINTS - ASSEMBLY

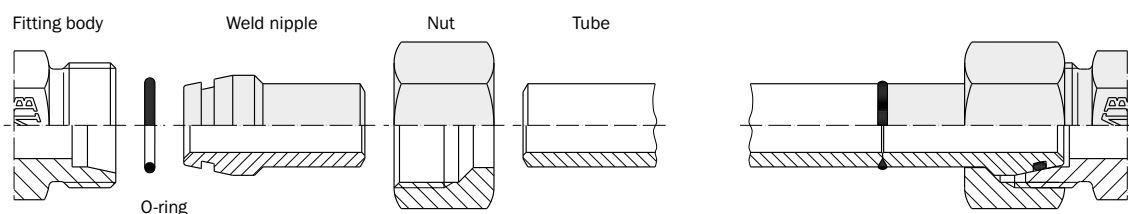

- Determining the tube length.
- Measure distance between fitting ends.
- Deduct dimension X from each fitting.
- Reduce pipe end by L1 when cutting rings have to be replaced.
- Cut the tube at right angles.
- Chamfer tube outside end.
- Deburr for welding purposes inside.
- Clean appropriately.
- Place the nut on the welding nipple.
- Weld nipple and tube.
- Descale the weld and clean the O-ring groove.
- Place the separately supplied O-ring.

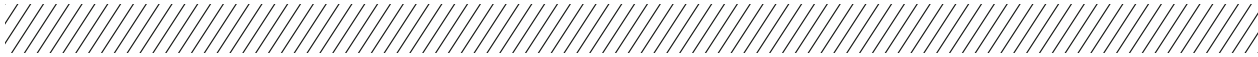

- Oil the thread.
- O-ring must not be twisted.
- Tighten nut by hand.
- The nut has to be tightened by 1/3 of a turn beyond the point of a noticeable increase in force.
- Hold the fitting body by means of a spanner.
- While assembling, torsion in the connecting tube must be avoided.
- Application of deviating numbers of tightening turns reduces the nominal pressure rating and the life of the fitting which causes leakages or other reasons of failure.

### FLARE FITTING DIN 24° - CHARACTERISTICS

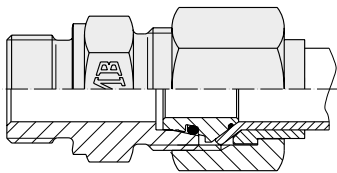

Before tightening the nut

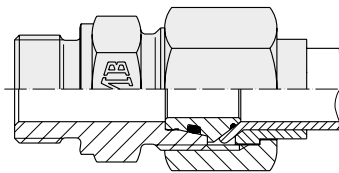

After tightening the nut

#### Function of the flare fitting

Gates flare fitting's ideal design, which consists of four components, ensures the secure and tight connection of flared tubes and standardised fitting bodies according to DIN 2353 / ISO 8434-1 and 4.

#### Fitting components:

Fitting body to DIN / ISO.

Flare adaptor DIN 3949.

Support ring DIN 3949.

Nut DIN 3949.

The central component – flare adaptor – effects the transition from the 24° taper of the fitting body to the SAE 37° flare connection. O-rings ensure sealing at the body taper and the flare connection. Thus a high degree of sealing efficiency is ensured, even under alternating pressure load. As the nut is tightened, the flare adaptor is pressed into the fitting taper with deformation of the retaining collar, until the collar at the flare adaptor is in full contact with the fitting body thus preventing further penetration and detrimental expansion of the fitting body. Having been tightened, the centre unit is captured in the fitting body – a great help to the operator during reassembly. The fitting can be dismantled and reassembled as often as necessary. The support ring provides secure and notch free tube clamping and high fatigue resistance under bending load.



## Flare tube fittings

- High degree of fine sealing efficiency.
- Elastomeric sealing at both sectioning points.
- No setting of the connection.

## No setting of the connection

- Improved connection between centre unit and fitting body.
- Reduced surface pressure between tube and support ring.

## Secure tube connection

- Larger flare and adapted loose collar.
- High tensile strength.
- No risk of disconnection when tightened insufficiently.

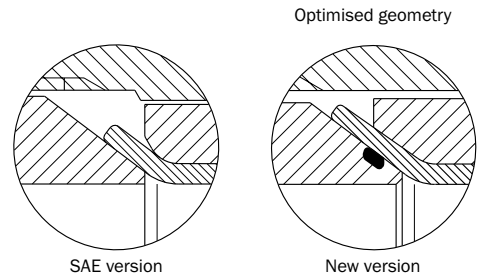
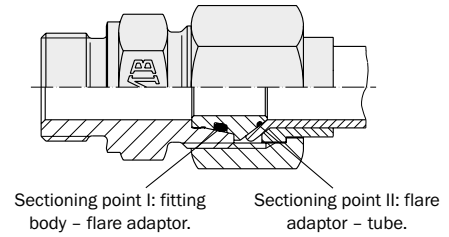

## FLARE FITTING DIN 24° - ASSEMBLY

### Assembly/reassembly

- Cut the tube rectangularly. Do not use a pipe cutter!
- Deburr the tube inside and outside. Do not chamfer!
- Clean off swarf and dirt.
- Lubricate flare connection parts and place them on the pipe. For stainless steel fittings (e.g. 1.4571) it is necessary to use a special lubricant (Gates lubricant "Gleitpaste").
- Flare pipe end. Check for possible cracks.
- Insert flare adaptor into fitting and apply flared pipe to the body. Tighten by hand.
- Use spanner to tighten with one to one and a half turn.
- Each time the fitting is disconnected, the nut must be retightened without using excessive force.

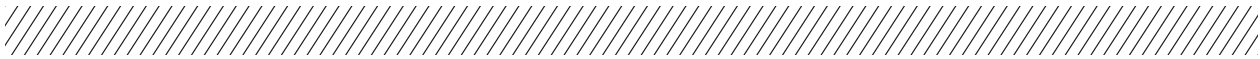

## Material

Flare fittings are machined from drawn steel bars or forgings.

The surface is phosphated and oiled (ISO 4042). Other surface protections are available.

Stainless steel (1.4571) is available.

Serial seal is NBR (e.g. Perbunan\*).

Temperature range from -35 °C to +100 °C.

FKM upon request (e.g. Viton\*).

Temperature range from -25 °C to +200 °C.

When using different materials for fittings and seals, the lowest temperature limits must be respected.

A tube quality suitable for flaring should be used, preferably a seamless precision steel tube of DIN 2391/C material St. 35, NBK.

## Nominal pressures

Series	Pipe OD	Nominal pressure
L	6-10	500 bar
L	12-18	400 bar
L	22-42	250 bar
S	6-16	630 bar
S	20-38	400 bar

Gates flare fittings are made in two different series. These are suitable for use at the following pressures:

- When the nominal pressure for certain type of fittings differ from those shown above, the nominal pressures indicated for the individual types should be taken into account.
- The nominal pressure of steel-type flare fittings is based on a safety factor of 4 (DIN 3859). Use at lower pressure range consequently results in higher safety. The nominal pressure presupposes uniform load conditions at temperatures up to +120 °C. Allowances must be made for working conditions involving heavy impact pressure, mechanical strain and vibration.

\* Registered trademark of BAYER AG.

\*\* Registered trademark of DU PONT.



## FLARE FITTING DIN 24° - TUBE DIMENSION

### Determining the tube length

The correct tube length is determined by measuring the distance between the fitting body ends. Dimension X is then deducted from each connection.

Tube dimension	X	L <sub>1</sub>
6x1	1	8
6x1.5	2	9
8x1	1	8
8x1.5	2	9
8x2	2.5	9.5
10x1	1	8
10x1.5	2	9
10x2	3	10
12x1	1	8
12x1.5	2	9
12x2	3	10
14x1.5	0.5	8.5
14x2	1	9
14x2.5	2	10
14x3	3	11
15x1.5	1	8
15x2	2	9
15x2.5	3	10
16x1.5	0	8.5
16x2	1	9.5
16x2.5	1.5	10
16x3	2.5	11
18x1.5	0	7.5
18x2	1	8.5
18x2.5	1.5	9
20x2	1	11.5
20x2.5	2	12.5
20x3	3	13.5
20x3.5	4	14.5
22x1.5	1	8.5
22x2	2	9.5
22x2.5	3	10.5
22x3	3.5	11
25x2	1	13
25x2.5	1.5	13.5
25x3	2.5	14.5
25x4	4	16
28x2	1.5	9
28x2.5	2.5	10
28x3	3	10.5
30x2	0.5	13
30x2.5	0.5	14
30x3	1	14.5
30x4	3	16.5
30x5	4.5	18
35x2	1.5	12
35x2.5	2	12.5
35x3	3	13.5
35x4	4.5	15
38x2.5	0	16
38x3	0.5	16.5
38x4	2	18
38x5	4	20
42x2	1.5	12.5
42x3	3	14
42x4	4.5	15.5

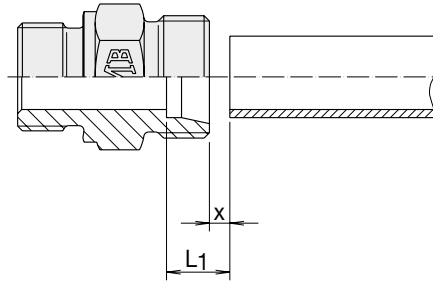



### Checking the flared tube

Tube cut off at right angles; lightly deburr both inside and outside. Do not chamfer.

If the flare is too short, perfect function of the fitting cannot be guaranteed!

Tube dimension dxs	Check dia Da min	Check dia Da max
6x1	9.1	10
6x1.5	9.1	10
8x1	11.3	12
8x1.5	11.3	12
8x2	11.3	12
10x1	13.1	14
10x1.5	13.1	14
10x2	13.1	14
12x1	15.3	16
12x1.5	15.3	16
12x2	15.3	16
14x1.5	18.6	19.6
14x2	18.6	19.6
14x2.5	18.6	19.6
14x3	18.6	19.6
15x1.5	19.1	20
15x2	19.1	20
15x2.5	19.1	20
16x1.5	20.6	22
16x2	20.6	22
16x2.5	20.6	22
16x3	20.6	22
18x1.5	23.2	24
18x2	23.2	24
18x2.5	23.2	24
20x2	25.6	26.8
20x2.5	25.6	26.8
20x3	25.6	26.8
20x3.5	25.6	26.8
22x1.5	26.5	27.5
22x2	26.5	27.5
22x2.5	26.5	27.5
22x3	26.5	27.5
25x2	31.1	33
25x2.5	31.1	33
25x3	31.1	33
25x4	31.1	33
28x2	32.7	33.3
28x2.5	32.7	33.3
28x3	32.7	33.3
30x2	37	38.7
30x2.5	37	38.7
30x3	37	38.7
30x4	37	38.7
30x5	37	38.7
35x2	41.8	42.7
35x2.5	41.8	42.7
35x3	41.8	42.7
35x4	41.8	42.7
38x2.5	46	47.2
38x3	46	47.2
38x4	46	47.2
38x5	46	47.2
42x2	48.8	49.8
42x3	48.8	49.8
42x4	48.8	49.8

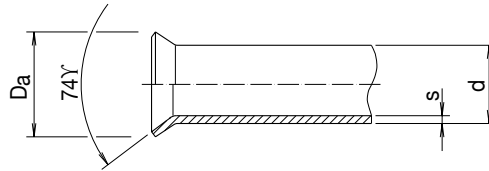

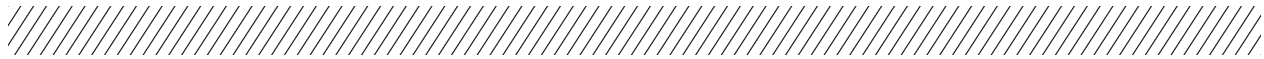

## Straight tube length to start of bending radius

Bend first – flare later

Straight tube length ( $L_1$ ) to start of bending radius:

- Manual flaring tool
- Flaring machine

Tube OD	$L_1$ Flaring machine UNIPRESS
6	43
8	44
10	46
12	47
14	50
15	50
16	52
18	58
20	58
22	60
25	60
28	60
30	62
35	62
38	70
42	70

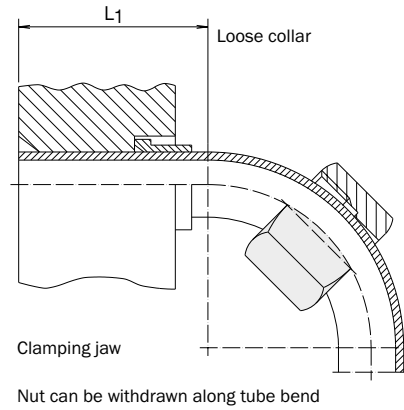

Flare first – bend later

If installation problems demand that the straight tube length (dimension  $L_2$ ) has to be shorter than indicated in the table, bending must be carried out after flaring.

Tube OD	$L_2$
10	15
12	15
15	17
16	21
18	18

Tube OD 6, 8 and 14 upon request.

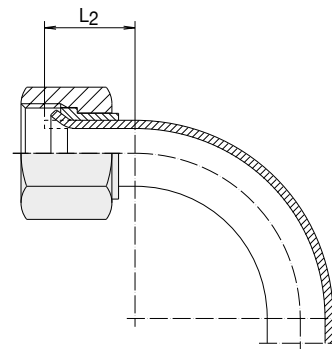

## Minimum straight tube length L

Tube OD	Series	L Flaring machine UNIPRESS
6	L	59
8	L	62
10	L	64
12	L	67
15	L	75
18	L	76
22	L	81
28	L	88
35	L	92
42	L	130
6	S	61
8	S	64
10	S	66
12	S	68
14	S	74
16	S	79
20	S	82
25	S	94
30	S	96
38	S	136

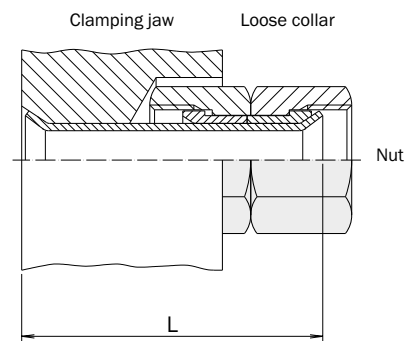
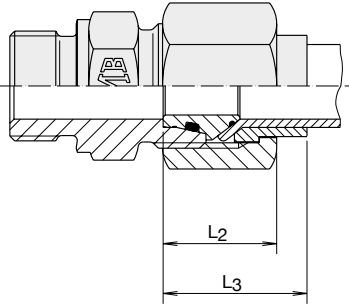

Table for length correction



The dimensions marked X in the following table represent the tube wall thicknesses on which the lengths in the lists of dimensions are based. For other tube wall thicknesses, the lengths have to be modified by the corrected dimension taken from the table.

Tube OD	Series	L2	L3
6	L	17.5	20.5
8	L	18.5	21.5
10	L	19.5	24
12	L	20	24.5
15	L	21.5	25.5
18	L	23	27
22	L	24	30.5
28	L	26	31.5
35	L	30	36
42	L	34	40
6	S	17.5	20.5
8	S	18.5	21.5
10	S	20	24.5
12	S	20.5	25
14	S	23	27.5
16	S	25	31
20	S	27.5	33
25	S	31	38.5
30	S	33	41.5
38	S	37.5	48

Tube OD	Series	Corrective dimension Tube wall thickness							
		1	1,5	2	2,5	3	3,5	4	5
6	L	X	+1						
8	L	X	+1	1.5					
10	L	-1	X	+1					
12	L	-1	X	+1					
15	L		X	+1	+2				
18	L		-1	X	+1				
22	L		-1	X	+1	1.5			
28	L			-1.5	-0.5	X			
35	L			-1.5	-1	X		1.5	
42	L			-1.5		X		1.5	
6	S	X	+1						
8	S	X	+1	1.5					
10	S	-1	X	+1					
12	S	-1	X	+1					
14	S		-0.5	X	+1	+2			
16	S		-1	X	0.5	1.5			
20	S			X	+1	+2	3		
25	S			-1.5	-1	X		1.5	
30	S			-2	-1	X		+2	3.5
38	S				-0.5	X		1.5	3.5





## HOW TO INTERPRET?

The following table gives rationalised conversion pressures from MPa to psi according to the SAE J517 standard for hydraulic hoses. These reference pressures allow the user to relate the new MPa pressure number to the former even psi number, 3000 psi relates to 21 MPa with the mathematically correct conversion being 21 MPa equal to 3045 psi. Allowing for the use of the most common available pressures this table will assist in relating the old psi numbers to the new ISO standards that will use either MPa or Bar.

### MPa to psi

MPa	Bar	Relative psi	Actual psi
3.5	35	500	507.5
7	70	1000	1015
14	140	2000	2030
21	210	3000	3045
28	280	4000	4060
35	350	5000	5075
42	420	6000	6090
49	490	7000	7105

Note: 1MPa = 10 Bar = 145 psi

### Inches - millimetres

Inches		Millimetres
Fraction	Decimals	
1/64	0.015625	0.397
1/32	0.03125	0.794
3/64	0.046875	1.191
1/16	0.0625	1.588
5/64	0.078125	1.984
3/32	0.09375	2.381
7/64	0.109375	2.778
1/8	0.125	3.175
9/64	0.140625	3.572
5/32	0.15625	3.969
11/64	0.171875	4.366
3/16	0.1875	4.763
13/64	0.203125	5.159
7/32	0.21875	5.556
15/64	0.234375	5.953
1/4	0.250	6.350
17/64	0.265625	6.747
9/32	0.28125	7.144
19/64	0.296875	7.541
5/16	0.3125	7.938
23/64	0.359375	9.128
3/8	0.375	9.525
25/64	0.390625	9.922
13/32	0.40625	10.319
27/64	0.421875	10.716
7/16	0.4375	11.113
29/64	0.453125	11.509
15/32	0.46875	11.906
31/64	0.484375	12.303
1/2	0.500	12.700
33/64	0.515625	13.097
17/32	0.53125	13.494
35/64	0.546875	13.891

Inches		Millimetres
Fraction	Decimals	
9/16	0.5625	14.288
37/64	0.578125	14.684
19/32	0.59375	15.081
39/64	0.609375	15.478
5/8	0.625	15.875
41/64	0.640625	16.272
21/32	0.65625	16.669
11/16	0.6875	17.463
45/64	0.703125	17.859
23/32	0.71875	18.256
47/64	0.734375	18.653
3/4	0.750	19.050
49/64	0.765625	19.447
25/32	0.78125	19.844
51/64	0.796875	20.241
13/16	0.8125	20.638
53/64	0.828125	21.034
27/32	0.84375	21.431
55/64	0.859375	21.828
7/8	0.875	22.225
57/64	0.890625	22.622
29/32	0.90625	23.019
59/64	0.921875	23.416
15/16	0.9375	23.813
61/64	0.953125	24.209
31/32	0.96875	24.606
63/64	0.984375	25.003

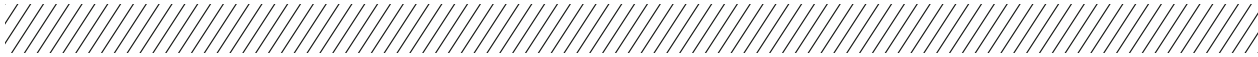

## Metric (SI) - Imperial units for Hose and Connectors use

Quantity	Imperial unit	Metric (SI) unit	Conversion from imperial to SI unit	Conversion from SI to imperial unit
Area	Square inch (in <sup>2</sup> )	Square metre (m <sup>2</sup> )	(in <sup>2</sup> ) x (6.4516 x 10 <sup>-4</sup> ) = (m <sup>2</sup> )	(m <sup>2</sup> ) x 1550.003 = (in <sup>2</sup> )
Force	Pound (lbf)	Newton (N)	(lbf) x 4.4482 = (N)	(N) x (2.2481 x 10 <sup>-1</sup> ) = (lbf)
Frequency	Cycles/second (cps)	Hertz (Hz)	1 (cps) = 1 (Hz)	1 (Hz) = 1 (cps)
Length	Inch (in)	Metre (m)	(in) x (2.540 x 10 <sup>-2</sup> ) = (m)	(m) x 39.370 = (in)
Mass	Pound (lbm)	Kilogram (kg)	(lbm) x 0.4536 = (kg)	(kg) x 2.2046 = (lbm)
Power	Electric horsepower (HP)	Watt (W)	(HP) x (7.460 x 10 <sup>2</sup> ) = (W)	(W) x (1.3405 x 10 <sup>-3</sup> ) = (HP)
Pressure	Pounds/sq in (psi)	Newtons/sq metre (N/m <sup>2</sup> )	(psi) x (6.8948 x 10 <sup>3</sup> ) = (N/m <sup>2</sup> )	(N/m <sup>2</sup> ) x (1.4504 x 10 <sup>-4</sup> ) = (psi)
	(psi) (psi) (bar)	Mega Pascal (MPa) Bar (bar) (N/m <sup>2</sup> )	(Non-preferred conversions) psi/145 = MPa psi/14.5 = bar (bar) x 100000 = (N/m <sup>2</sup> )	(MPa) x 145 = (psi) (bar) x (1.4504 x 10 <sup>1</sup> ) = (psi) (N/m <sup>2</sup> ) x (1.00 x 10 <sup>-5</sup> ) = (bar)
Temperature	Degrees Fahrenheit (°F)	Degrees Celsius (°C)	(°Celsius) = 0.556 (°F-32)	(1.8°C) + 32 = °F
Torque	Pound-inch (lbf-in)	Newton-metres (Nm)	(lbf-in) x (1.1298 x 10 <sup>-1</sup> ) = (Nm)	(Nm) x 8.8507 = (lbf-in)
Volume	US gallon (gal)	Cubic metre (m <sup>3</sup> )	(gal) x (4.543 x 10 <sup>-3</sup> ) = (m <sup>3</sup> )	(m <sup>3</sup> ) x (2.201 x 10 <sup>2</sup> ) = (gal)
		Litre (l)	(Non-preferred conversions) (gal) x 4.543 = (l)	(l) x (2.201 x 10 <sup>-1</sup> ) = (gal)
Work	Foot-pound (ft-lbf)	Joule (J)	(ft-lbf) x 1.3558 = (J)	(J) x (7.3756 x 10 <sup>-1</sup> ) = (ft-lbf)





**DRIVEN BY POSSIBILITY™**

**CUSTOMER EXPERIENCE TEAM**

CONTACT BY MAIL:  
GATESCSIR@GATES.COM

CONTACT BY PHONE (PER SPOKEN LANGUAGE):  
+48718814503 - ENGLISH  
+48718814502 - POLISH  
+48718814505 - GERMAN