



OPERATING MANUAL
TUBE END FORMING MACHINE
FS 94



GATES TUBE FITTINGS GMBH

CONTENTS PAGE

1. General information	4	5. Start-up.....	10
2. Basic safety instructions.....	5	5.1 Set-up.....	10
2.1 Obligations and liability	5	5.2 Exchanging the screwed sealing plug	10
2.2 Safety symbols	5	5.3 Tube quality.....	10
2.3 Hazards when handling the machine	5	5.4 Tube machining	10
2.4 Safety devices.....	6	5.5 Tool change.....	11
2.5 Intended use.....	6	5.6 Operation	12
2.6 Informal safety measures to be performed by the operator.....	6	Important instructions	13
2.7 Obligations of the operator/personnel	6	6. Shutdown, disposal.....	14
2.8 Training of personnel.....	6	6.1 Shutdown	14
2.9 Workstation for the operating personnel....	6	6.2 Disposal	14
2.10 Hazards caused by electrical and hydraulic energy.....	6	7. Maintenance	15
2.11 Cleaning the machine	7	7.1 Oil quality	15
2.12 Structural changes to the assembly machine FS 94.....	7	7.2 Oil change	15
3. Transporting the assembly machine	7	7.3 Cleaning the machine	15
3.1 Transport.....	7	7.4 Cleaning and care of the tools.....	15
3.2 Transport damages.....	7	8. Inspection and maintenance list.....	16
4. Description of the assembly machine FS 94....	8	9. Error causes	17
4.1 Description.....	8	10. Customer/aftersales service	18
4.2 Overall view.....	8	11. FS system	20
4.3 Operating and display elements	8	12. Machine and tools	21
4.4 Technical data	9	12.1. Technical data of machine.....	21
4.5 Marking of the assembly machine FS 94... 9		12.2. Usable tube sizes – steel	21
		12.3. Usable tube sizes – high-grade steel (1.4571)	22

13. Tools.....	23	17. Assembly with FSSR ring in the fitting body (for thin tubes).....	31
13.1. Clamping tools.....	23	17.1. Sliding the FSSR ring onto the tube	31
13.2. Forming tools.....	23	17.2 Pressing the tube into the 24° connector	31
13.3. Tool list.....	24	17.3. Tightening the nut finger-tight.....	31
14. Accessories	25	17.3. Completing assembly.....	31
14.1. Sealing and back-up rings – steel	25	18. Tube length shortening for steel.....	32
14.2. Sealing and back-up rings – high-grade steel	26	19. Tube length shortening for high grade steel ...	33
15. Forming.....	27	20. Minimum straight tube length	34
15.1. Determining the tube length.....	27		
15.2. Sawing tubes	27		
15.3. Checking machine settings and tools ...	27		
15.4. Sliding nut onto tube.....	27		
15.5. Forming the tube.....	27		
15.6. Inspecting the formed tube Visual inspection.....	28		
16. Assembly with FSR ring in the fitting body	30		
16.1. Pressing the FSR ring into the fitting body	30		
16.2. Pressing the tube against the 24° inclination.....	30		
16.3. Tightening the nut finger-tight.....	30		
16.4. Completing assembly.....	30		

1. GENERAL INFORMATION

Identification data	Type of machine Model designation	Assembly machine FS 94
Manufacturer address	Company name Street Town Telephone	Gates Tube Fittings GmbH Kolumbusstrasse 54 D-53881 Euskirchen 0 22 51 / 12 56 - 0
Ordering of spare parts and customer service		See address above
Document		Version: 1.0 Date of creation: 04.02.2020

2. BASIC SAFETY INSTRUCTIONS

This operating manual contains important instructions for operating the machine in a safe manner.

2.1 OBLIGATIONS AND LIABILITY

- Knowing the basic safety instructions and safety regulations is a basic requirement for the safe handling and smooth operation of this machine.
- This operating manual, and in particular the safety instructions contained in it, are to be complied with by all persons who work on the machine.
- In addition, the rules and regulations for accident prevention that are applicable for the site of operation are to be adhered to and the prescribed inspection and maintenance work carried out.
- Our general terms and conditions of sale and delivery are generally applicable. These will be made available to the operator no later than on the date the contract is concluded. Guarantee and liability claims for any personal injuries and damage to property are excluded if they are due to one or more of the following causes:
 - The machine not being used in accordance with its intended purpose
 - Incorrect set-up, start-up, operation and maintenance of the machine
 - Operation of the machine with defective safety devices or incorrectly attached and non-functional safety devices
 - Ignoring the instructions in this operating manual
 - Unauthorised structural modifications to the machine
 - Poor monitoring of machine parts that are subject to wear
 - Improper performance of repairs
 - Emergencies caused by external influence or force majeure

2.2 SAFETY SYMBOLS

The following pages describe the safety instructions and safety requirements.

Explanation of hazard and other symbols

In this operating manual, the following terms and symbols are used to denote hazards and instructions:

PROHIBITION SYMBOL

This prohibition symbol means that the activities or things mentioned are to be strictly refrained from.

WARNING SYMBOL

This symbol means:

- *An immediate and imminent danger to the life and health of persons. Not adhering to these instructions will result in severe adverse health effects with the possibility of lifethreatening injuries.*
- *A possible danger to the life and health of persons. Not adhering to these instructions may result in severe adverse health effects with the possibility of lifethreatening injuries.*
- *A potentially dangerous situation. Not adhering to these instructions may result in minor injuries or damage to property.*

2.3 HAZARDS WHEN HANDLING THE MACHINE

The machine has been constructed in accordance with state-of-the-art technology and the recognised safety rules and regulations. Nevertheless, its use may constitute a risk for the life and physical condition of the user or of third parties, or cause damage to the machine and to other property.

- The machine must only be used
 - For its intended purpose,
 - In perfect working order with regard to safety.
- Any malfunctions which may compromise safety are to be immediately eliminated or reported to the manufacturer.

2.4 SAFETY DEVICES

The assembly machine FS 94 has the following safety devices

- Emergency stop switch
- Bell with sensor and warning
- Pressure limitation valve
- Housing cover
- Two-hand control
- Before starting up the assembly machine, all safety devices must always be properly attached and functional.
- Safety devices may be only removed
 - After shutdown and
 - Once the power supply plug has been pulled out.

All safety devices are to be checked on a regular basis.

2.5 INTENDED USE

The machine may only be used for forming contours on hydraulic tubes. The tubes approved are steel tubes (E235+N, E355+N) in accordance with DIN EN 10305-4 and high-grade steel tubes (1.4571) in accordance with DIN 10216-5, min. tolerances D4/T3.

2.6 INFORMAL SAFETY MEASURES TO BE PERFORMED BY THE OPERATOR

- The operating manual must always be kept on the site where the machine is used.
- In addition to the operating manual, the generally applicable and local regulations for accident prevention and environmental protection are to be made available and complied with.
- All notices affixed to the machine must be kept legible.

2.7 OBLIGATIONS OF THE OPERATOR/ PERSONNEL

The operator/personnel commit themselves to only allowing persons to work on the machine who

- Are familiar with the fundamental regulations on occupational health and safety and accident prevention and have been instructed regarding the handling of the machine.
- Have read and understood the operating manual read and/or have been introduced to the machine, and confirmed with their signature.

2.8 TRAINING OF PERSONNEL

- Only trained and instructed personnel may work on the machine.
- The responsibilities of personnel are to be clearly specified for the putting out, selecting and inserting of tools, for start-up, for operation and for the performance of inspection and maintenance work on the machine.
- Trainee personnel may only work on the machine when supervised by an experienced person.

2.9 WORKSTATION FOR THE OPERATING PERSONNEL

- The work area is located in front of the machine.
- The workstation is to be kept clean and tidy near and around the machine and regular checks must be made to ensure this.

2.10 HAZARDS CAUSED BY ELECTRICAL AND HYDRAULIC ENERGY

- Work may only be carried out on the electrical and hydraulic power supply by a trained member of staff.

2.11 CLEANING THE MACHINE

Used substances and materials should be correctly handled and disposed of, in particular

- When working on the hydraulics and
- When cleaning with solvents.

2.12 STRUCTURAL CHANGES TO THE ASSEMBLY MACHINE FS 94

It is forbidden to make any changes, fittings or modifications to the machine without the manufacturer's consent. Machine parts that are not in perfect working order are to be exchanged immediately.

Only original spare and wear parts are to be used.

Spare parts from elsewhere cannot be guaranteed to have been designed and manufactured in such a way as to fulfil the operational stress and safety requirements.

3. TRANSPORTING THE ASSEMBLY MACHINE

3.1 TRANSPORT

The machine is only intended for transport using forklifts and industrial trucks. The machine can be lifted and transported using the forks beneath the frame. Observe the relevant regulations.

3.2 TRANSPORT DAMAGES

- Any transport damages determined must be noted on the shipping documents.
- The responsible supplier (normally the truck driver) must confirm the determined damage on the shipping documents by affixing his signature.
- Transport damages are to be reported to the manufacturer as soon as possible.

4. DESCRIPTION OF THE ASSEMBLY MACHINE FS 94

4.1 DESCRIPTION

The machine is intended exclusively for manufacturing the Gates-FS™ form on hydraulic tubes sized 6-42 mm, for material see point 5.3.

The machine may only be used for the intended operating conditions. The intended use also includes:

- The observance of all instructions in the operating manual
- The performance of prescribed inspection and maintenance work.

4.2 OVERALL VIEW



4.3 OPERATING AND DISPLAY ELEMENTS

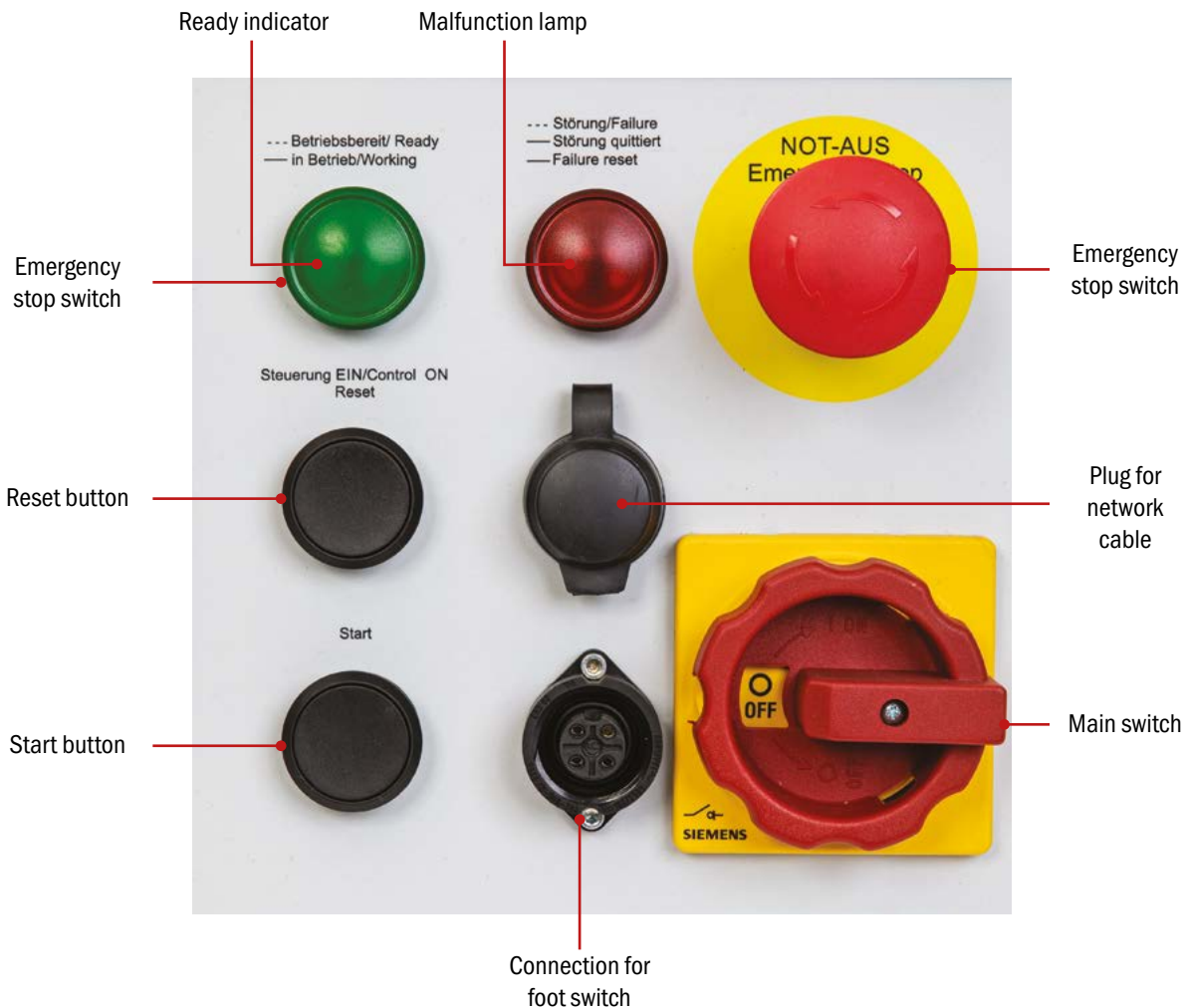

4.4 TECHNICAL DATA

4.4.1 General data

Width	740 mm
Depth	860 mm
Height	350 mm
Weight (without tools)	195 kg

4.4.2 Power supply

Voltage	400 V
Fuse protection	16 A
Operating pressure	600 bar max.
Power	3.5 kW

Voltage supply in accordance with IEC 60038 is required, since machine will not function correctly otherwise.

4.4.3 Ambient conditions

Min. ambient temperature	+5 °C
Max. ambient temperature	+35 °C
Max. relative humidity	80%

If the machine is to be put into storage for more than 6 months (for sea transit for example), please consult the manufacturer. The machine must be specially protected in this case.

4.4.4 Hydraulic oil

Oil type	HLP 46
Oil quantity	approx. 7 L

4.4.5 Noise level

Noise level	≤ 72 dB(A)
-------------	------------

4.5 MARKING OF THE ASSEMBLY MACHINE FS 94

The type plate and the CE marking can be found on the front side of the machine.

5. START-UP

5.1 SET-UP

The ground on which the machine is to be set up must be adequate to bear the weight of the machine and ensure its stability.

The assembly machine FS 94 is ready for operation:

- Once the sealing plug has been exchanged for the vent screw/ see point 5.2,
- Once the machine has been properly connected to the power supply 400 V/ 16 A,
- Once the tool has been selected and inserted,
- Once the bell has been closed
- After the direction of rotation has been verified

IMPORTANT

The machine is to be protected against weathering.

IMPORTANT

When working on the electrics, mechanics and hydraulics, the machine is to be shut off from the electricity supply.

5.2 EXCHANGING THE SCREWED SEALING PLUG

For transporting the machine, the tank is sealed with a screwed sealing plug for reasons of safety.

For start-up, it is necessary to remove the screwed sealing plug and to exchange it for the enclosed ventilation connector.

To do so, remove the cover from the machine and the screwed sealing plug. Now insert the ventilation connector and fasten it finger-tight.

Keep the screwed sealing plug (VSCH) for possible transportation.

IMPORTANT

For transporting the machine, the tank must be sealed with a screwed sealing plug.

For operating the machine, the screwed sealing plug must be exchanged for a ventilation connector.

5.3 TUBE QUALITY





- Seamless, cold-bending and flangeable tube materials in accordance with EN 10305-4 (EN235+N, EN355+N) or high-grade steel tubes (1.4571) in accordance with DIN 10216-5 are to be used.
- The tube tolerances for high-grade steel tubes (1.4571) must correspond to at least D4/ T3 for the outside and inside diameter.
- A perfect condition of tube is to be used, and the tube must show no signs of damage.

5.4 TUBE MACHINING

The tube ends

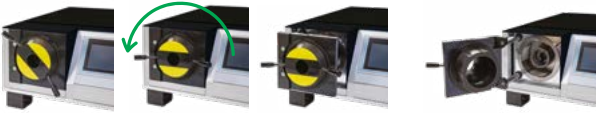
- Must be deburred on the inside and outside, chamfer of 0.2x45° maximum
- Are to be sawn off at right angles, without using a tube cutter or cut-off wheel
- Must be cleaned in the clamping and deformation area and freed from paint, grease, oil, dust and impurities.

5.5 TOOL CHANGE

 <p>FOW SPW92</p>	<p>1. Tools must be available for start-up.</p>
	<p>2. Push back the tool flap.</p>
	<p>3. Before inserting the tools it must be made sure that they are free from shavings and impurities.</p>
	<p>4. Worn or defective tools are to be exchanged immediately.</p>
	<p>5. Forming connectors are to be inserted as shown in the picture. (bayonet fixing)</p>
	<p>6. Clamping jaws are to be inserted as shown in the picture. The running surface of the tool flap must always be slightly greased. After inserting, <u>press the start button</u>.</p>
	<p>7. Close the tool flap.</p>

 **IMPORTANT**





Make sure that the tools fit the desired tube size.





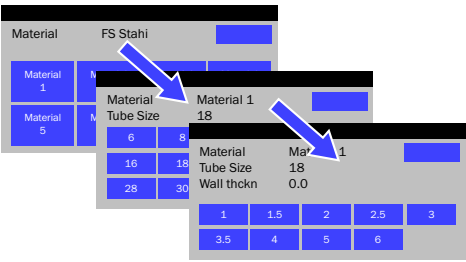
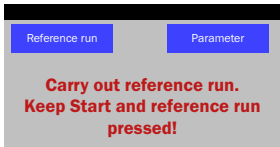

5.6 OPERATION

5.6.1 General

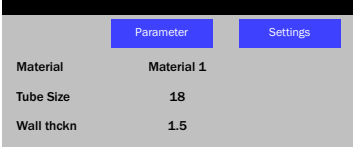
The system has a user-friendly design. The functions and status indicators are very wide-ranging and differentiated. Personnel should therefore be thoroughly informed before or while the system is started up for the first time, or at least have read and understood the following information.

5.6.2 Tube forming procedure

	<ol style="list-style-type: none"> 1. Plug in the power cable. 2. Switch on the main switch. 3. Unlock the emergency stop switch if necessary 4. Press reset 5. The machine will go into its default setting
	<ol style="list-style-type: none"> 6. Open the tool flap.
	<ol style="list-style-type: none"> 7. "Tool change" will appear on the display. 8. Please make sure that the right tool has been inserted
	<ol style="list-style-type: none"> 9. Insert tool (refer to 5.5) 10. The display will show "to enter the tool, press the start button". Please press the start button and then close the tool flap.
	<ol style="list-style-type: none"> 11. This will automatically appear after closing the tool flap. Select Parameters first.
	<ol style="list-style-type: none"> 12. Select material, outer tube diameter and wall thickness.
	<ol style="list-style-type: none"> 13. Perform a reference run. To do this, hold down "reference run" on the display and the start button both at once until the reference run is complete and the machine has reached insertion position.

	<p>14. Chance to check all inputs again.</p>
	<p>15. Slip the nut over the tube before forming.</p>
	<p>16. Push the prepared tube through the clamping jaws and into the machine as far as it will go.  Never form a side of a tube twice or reach with your hands into the tool.</p>
	<p>17. Press the start key and hold the tube at a sufficient distance.</p>
	<p>18. The tube will be clamped and formed.</p>
	<p>19. Once the forming process is complete, the clamping jaw will automatically open. The tube can now be taken out.  Beware of falling workpieces.</p>
	<p>20. Then examine the result and check after assembly that the tube has no damages (cracks, chips, etc.). Gates FS gauges can be used to check the contour.</p>

IMPORTANT INSTRUCTIONS

 **IMPORTANT**

Never form or clamp the same side of tube ore than once.

 **IMPORTANT**

Never reach into the machine.

 **IMPORTANT**

Beware of falling workpieces.

6. SHUTDOWN, DISPOSAL

6.1 SHUTDOWN

Turn the main switch to 0. Inadvertent restarting can be prevented by placing a padlock on the main switch.



6.2 DISPOSAL

- Dispose of machine parts by material. Observe national regulations
- Always dispose of machine parts in accordance with local environmental conditions
- Dispose of oil residue properly and in an environmentally friendly manner

7. MAINTENANCE

7.1 OIL QUALITY

Use hydraulic oil quality HLP 46 in accordance with DIN 51524 part 2.

7.2 OIL CHANGE

Perform an oil change at least once a year.



IMPORTANT

The oil change may only be carried out by instructed persons.

Keep a suitable collection receptacle ready (7 litres approx.). Remove the ventilation connection at the lateral upper edge of the oil tank. A suitable suction device is needed to empty the oil tank.

Fill the oil tank with 7 litres of hydraulic oil (see 7.1). Use a funnel to do this and then turn the ventilation connector to retighten it without exerting undue force.



IMPORTANT

Ensure that the old oil is disposed of properly and in an environmentally friendly manner. The national regulations relevant in each case apply.

7.3 CLEANING THE MACHINE

The essential cleaning of the machine is limited to the cleaning of the work area and the outer care of the machine. Impurities, shavings, grease and oil are to be wiped off with a dry cloth and removed.



Instructions regarding cleaning

When using halogenated hydrocarbon based solvents and cleaning agents such as trichloroethane and methylene chloride (dichloromethane), chemical reactions can occur on aluminium as well as on galvanised parts. This can cause the components to oxidise. The reaction may be explosive in extreme cases. Therefore only cleaning agents may be used which do not contain the ingredients mentioned. Fire and naked flames are strictly forbidden.

7.4 CLEANING AND CARE OF THE TOOLS

- Before inserting the tools it must be made sure that they are free from shavings and impurities.
- Exchange worn and defective tools immediately.



IMPORTANT

Risk of injury by small metal splinters. Wear suitable personal protective equipment (gloves, safety goggles)

8. INSPECTION AND MAINTENANCE LIST

 **IMPORTANT**

The power plug is to be pulled out before working on the mechanics and hydraulics.

WHEN SHOULD THIS BE DONE?	WHAT SHOULD BE DONE?	WHERE SHOULD THIS BE DONE?	HOW THIS SHOULD BE DONE	WHO IS AUTHORISED TO DO THIS?
Daily	Check for damage visible on the outside	Entire machine	Visual inspection	Operator of the machine
Daily	Check that display elements are functioning		Visual inspection of indicator lamps	Operator of the machine
Daily	Check tools for wear and clean if necessary.		Visual inspection No damages may be visible in the profiling of the clamping jaws.	Operator of the machine
Monthly	Check position measuring system, tightening torque.		Torque spanner 100 Nm +5%	Instructed specialist
Monthly	Lightly grease bell			Operator
Every 3 months	Check oil level		Remove housing cover and check oil level on the inspection glass	Instructed specialist
Annually	Examine electrical and hydraulic equipment		Visual inspection No electricity! Padlock on main switch	Instructed specialist Consider the operating manual for the hydraulic supply
Annually	Examine electrical connections and retighten connection if necessary.	Switch cabinet and entire system	Check using screwdriver	Electrical specialist
Annually. Earlier where necessary. If hydraulic oil shows black colouring	Change hydraulic oil.			Instructed specialist Consider the operating manual for the hydraulic supply

9. ERROR CAUSES

 **IMPORTANT**

The liability and guarantee of Gates Tube Fittings GmbH will expire in the event of unauthorised disassembly of the machine or in the case of changes being made to components or components being exchanged for non-original components.

ERROR	POSSIBLE CAUSE	SOLUTION
Tube slips through the clamping jaw	Wrong clamping jaw Clamping jaw dirty	Insert the correct clamping jaw Clean and degrease the
	Clamping jaw worn	Exchange the clamping
	Wrong tube standard	Use correct tube standard
Tube considerably over-formed	Wrong size selected	Select the correct size
	Wrong material selected	Select the correct material
	Tube was inserted during the reference run	Only insert the tube after the reference run
	Tube was formed more than once	Never form tubes more than once
Tube considerably under-formed	Wrong size selected	Select the correct size
	Wrong material selected	Select the correct material
	Tube was not resting against the forming connector before the clamping jaw was closed.	Deburr tube and place tube against the forming connector before the forming process. IMPORTANT: Never form a side of tube more than once.
The machine goes sporadically into power-up cycle	Reference run was not completed due to the start or enabling key being inadvertently released.	Repeat reference run.
	Strong voltage fluctuations in the power supply, rotation direction monitoring triggered	Disconnect machine from the power supply.
Error message "check press switch"	One of the two press switches is defective. (Check inputs E1.3 and E1.4)	Contact Gates Tube Fittings GmbH
	Cable break or loose cable at one of the press switches	Contact Gates Tube Fittings GmbH
	Press switch incorrectly wired	Contact Gates Tube Fittings GmbH

10. CUSTOMER/AFTERSALES SERVICE

If none of the causes specified in chapter 9 can have caused the malfunction, please contact our customer service.

Before sending us the machine in the event of malfunction or for maintenance, please make sure you contact us by telephone first.

Telephone: 0 22 51 / 12 56 - 0

Please send to the following address:

Gates Tube Fittings GmbH

Street Kolumbusstrasse 54

Town D-53881 Euskirchen

Telephone 0 22 51 / 12 56 - 0

Please enclose the following information:

- Description of the error symptoms
- In the case of incorrect assembly, provide an example where appropriate
- Copy of the sale contract
- Serial number
- Name and telephone number of our contact

An appropriate form will be sent to you before shipping.

CE

EG-Konformitätserklärung

in the sense of the EC Machinery Directive 2006/42/EC, Annex II A



We, Gates Tube Fittings GmbH
Kolumbusstr. 54
D-53881 Euskirchen
Tel. +49 (0) 2251 1256 - 0
Fax +49 (0) 2251 1256 - 400,

hereby declare that the machine described below, on the basis of its design and construction, as well as the version that we have put into circulation, corresponds with the relevant fundamental health and safety requirements of EC directive 2006/42/EC.

Designation of the machine: FS-94 (equipment for tube end forming)

Type of machine: FS 94

Year of construction: 2019

Relevant EC directives:

- EC Electromagnetic Compatibility Directive 2004/108/EC

Applied harmonised standards:

- DIN EN ISO 12100-1 and 2, safety of machinery
- DIN EN 60204-1, electrical equipment of machines

**Name/address of the authorised representative
for the compilation of technical documentation:**

Markus Breinig
Gates Tube Fittings GmbH
Kolumbusstr. 54
D-53881 Euskirchen

Euskirchen, 04.02.2020
Place, date

Signature/stamp

TECHNICAL DOCUMENTATION FOR GATES - FS® SYSTEM

11. FS SYSTEM

In industrial applications where welded and flanged connections are currently used, direct tube forming offers an economical and technically reliable alternative.

With the Gates - FS system, a forming system with the entire range of sizes from 6-42 mm tube outside diameter of the DIN fitting in steel and high-grade steel is now available to the user.

The tube forming requirements in terms of cost saving and reliability based on DIN 2353 (fittings) are therefore consistently met by Gates FS.

- Considerable cost saving thanks to reduction of the system/process costs
- Simple and reliable assembly
- Functional reliability and high performance in operation

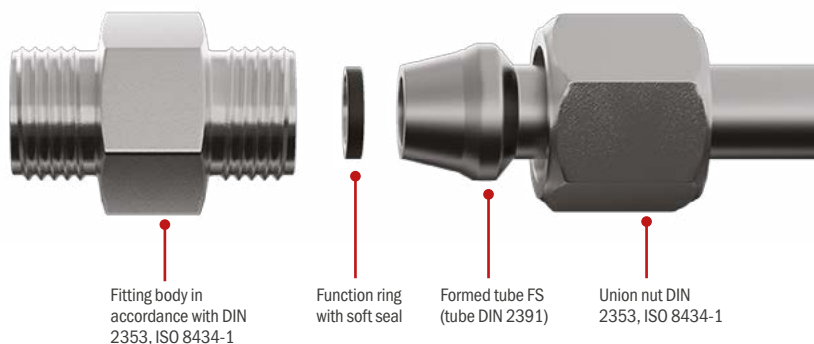

A non-cutting connection, the Gates FS system can also be used in safety-relevant areas where no cutting connections may be used.

The Gates FS system is based on the existing welded socket fittings in terms of form and function. The tube seat in the 24° inclination of the fitting body is known and established from the existing systems such as cutting ring, welded sockets or flange adapters. A secondary metallic sealing effect is obtained in this manner and above all a practical assembly.

The actual sealing function is assumed by a function ring on which a soft seal is vulcanised and which is inserted at the tube stop of the fitting body. The function ring is designed in such a way that the gap between the tube and the ring is closed if assembly is carried out correctly, thus creating a chamber for the soft seal. The second function of the ring is to prevent overassembly.

12. MACHINE AND TOOLS

To mount the FS contour onto the tube, an Gates forming machine and the appropriate tools are needed.

The electronically controlled Gates forming machine with integrated force-displacement control and the associated Gates forming tools ensure a consistent forming with a high economic efficiency.

A long service life is achieved through using high-quality materials and adhering to high quality standards for Gates deforming tools.

12.1. TECHNICAL DATA OF MACHINE

Refer to section 4.4.

12.2. USABLE TUBE SIZES – STEEL

TUBE	WALL										
	1.0	1.5	2.0	2.25	2.5	3.0	3.5	4.0	4.5	5.0	6.0
6	x	x									
8	x	x	x		x						
10	x	x	x		x	x					
12	x	x	x		x	x	x				
15			x		x	x					
16			x		x	x		x			
18			x		x	x					
20					x	x	x	x			
22			x		x	x	x				
25					x	x	x	x	x	x	
28					x	x	x	x		x	
30						x		x		x	x
35					x	x		x		x	x
38						x		x		x	x
42						x	x	x			

12.3. USABLE TUBE SIZES - HIGH-GRADE STEEL (1.4571)

TUBE	WALL										
	1.0	1.5	2.0	2.25	2.5	3.0	3.5	4.0	4.5	5.0	6.0
6	x	x									
8	x	x	x		x						
10	x	x	x		x	x					
12	x	x	x		x	x	x				
15			x		x	x					
16			x		x	x		x			
18			x		x	x					
20					x	x	x	x			
22			x		x	x	x				
25					x	x	x	x	x	x	
28					x	x	x	x		x	
30						x		x		x	
35					x	x		x		x	
38						x		x		x	
42						x	x	x			

13. TOOLS

To form a standard hydraulic tube in steel or high-grade steel, clamping tools (SPW92) and the associated forming tools (FOW) are required.

13.1. CLAMPING TOOLS

Gates FS clamping tools hold the tube securely in place during the forming process thanks to their tooth geometry. The four individual segments are captive and precisely interconnected. The high quality of the tools ensures a reliable forming and a long service life. A clamping tool is needed for each tube outside diameter. This is used for every wall thickness and every material.



13.2. FORMING TOOLS

Gates FS forming tools compress the tube through their axial movement and in doing so, form the 24° inclination into the tube. Changing the tool is very simple and quick to do thanks to the bayonet fixing used. The use of premium materials and the high quality ensure consistent forming and a long service life. In the case of standard wall thicknesses, a forming tool is needed for every tube outside diameter. This tool can be used for any material.



13.3. TOOL LIST

TUBE OUTSIDE DIAMETER X WALL THICKNESS	SPW92	FOW
6x1	6 L/S	6x1-1.5L/S
6x1.5		
8x1	8 L/S	8x1-1.5L/S
8x1.5		
8x2		8x2+L/S
8x2.5		
10x1	10 L/S	10x1-1.5L/S
10x1.5		
10x2		10x2+L/S
10x2.5		
10x3		
12x1	12 L/S	12x1-1.5L/S
12x1.5		
12x2		12x2+L/S
12x2.5		
12x3		
12x3.5		
15x2	15 L	15x2+
15x2.5		
15x3		
16x2	16 S	16x2+
16x2.5		
16x3		
16x4		
18x2	18 L	18x2+
18x2.5		
18x3		
20x2.5	20 S	20x2.5+
20x3		
20x3.5		
20x4		

TUBE OUTSIDE DIAMETER X WALL THICKNESS	SPW92	FOW
22x2	22 L	22x2+
22x2.5		
22x3		
22x3.5		
25x2.5	25 S	25x2.5+
25x3		
25x3.5		
25x4		
25x4.5		
25x5	28 L	28x2.5+
28x2.5		
28x3		
28x3.5		
28x4		
28x5	30 S	30x3+
30x3		
30x4		
30x5	35 L	35x2.5+
30x6		
35x2.5		
35x3	38 S	38x3+
35x4		
35x5		
35x6		
38x3	42 L	42x3+
38x4		
38x5		
38x6	42 L	42x3+
42x3		
42x3.5		
42x4		

14. ACCESSORIES

14.1. SEALING AND BACK-UP RINGS – STEEL

TUBE OUTSIDE DIAMETER X WALL THICKNESS	FSR	FSSR
6x1		6 L/S
6x1.5		
8x1	8 L/S	8 L/S
8x1.5		
8x2	8 L/S	
8x2.5		
10x1		10 L/S
10x1.5		
10x2	10 L/S	
10x2.5		
10x3		
12x1		12 L/S
12x1.5		
12x2	12 L/S	
12x2.5		
12x3		
12x3.5		
15x2	15 L	
15x2.5		
15x3		
16x2	16 S	
16x2.5		
16x3		
16x4		
18x2	18 L	
18x2.5		
18x3		
20x2.5	20 S	
20x3		
20x3.5		
20x4		

TUBE OUTSIDE DIAMETER X WALL THICKNESS	FSR	FSSR
22x2	22 L	
22x2.5		
22x3		
22x3.5		
25x2.5	25 S	
25x3		
25x3.5		
25x4		
25x4.5		
25x5		
28x2.5	28 L	
28x3		
28x3.5		
28x4		
28x5	30 S	
30x3		
30x4		
30x5	30 S	
30x6		
35x2.5		
35x3	35 L	
35x4		
35x5		
35x6		
38x3	38 S	
38x4		
38x5		
38x6		
42x3	42 L	
42x3.5		
42x4		

14.2. SEALING AND BACK-UP RINGS – HIGH-GRADE STEEL

TUBE OUTSIDE DIAMETER X WALL THICKNESS	FSR	FSSR
6x1		6 L/S-1.4571
6x1.5		
8x1	8 L/S-1.4571	8 L/S-1.4571
8x1.5		
8x2	8 L/S-1.4571	
8x2.5		
10x1	10 L/S-1.4571	10 L/S-1.4571
10x1.5		
10x2	10 L/S-1.4571	
10x2.5		
10x3		
12x1	12 L/S-1.4571	12 L/S-1.4571
12x1.5		
12x2	12 L/S-1.4571	
12x2.5		
12x3		
12x3.5		
15x2	15 L-1.4571	
15x2.5		
15x3	16 S-1.4571	
16x2		
16x2.5		
16x3		
16x4		
18x2	18 L-1.4571	
18x2.5		
18x3		
20x2.5	20 S-1.4571	
20x3		
20x3.5		
20x4		

TUBE OUTSIDE DIAMETER X WALL THICKNESS	FSR	FSSR
22x2	22 L-1.4571	
22x2.5		
22x3		
22x3.5		
25x2.5	25 S-1.4571	
25x3		
25x3.5		
25x4		
25x4.5		
25x5	28 L-1.4571	
28x2.5		
28x3		
28x3.5		
28x4		
28x5	30 S-1.4571	
30x3		
30x4		
30x5	35 L-1.4571	
30x6		
35x2.5		
35x3	38 S-1.4571	
35x4		
35x5		
35x6		
38x3	42 L-1.4571	
38x4		
38x5		
38x6	42 L-1.4571	
42x3		
42x3.5		
42x4		

15. FORMING

15.1. DETERMINING THE TUBE LENGTH

The tube is shortened by the deformation. The machining allowance for the tube length before forming is determined using the table on page 32/33.

15.2. SAWING TUBES

Saw the tube to be installed at a right angle and chamfer the edges.



 **IMPORTANT** Do not use a tube cutter

15.3. CHECKING MACHINE SETTINGS AND TOOLS

The machine settings are to be verified on the display and the tools checked at the time of start-up and when changing tube sizes. Refer also to the machine manual.

15.4. SLIDING NUT ONTO TUBE

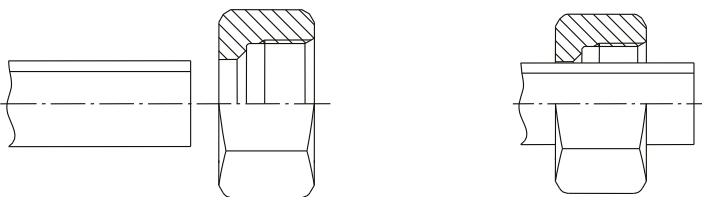

15.5. FORMING THE TUBE

Refer to point 5.6 Operation.

15.6. INSPECTING THE FORMED TUBE - VISUAL INSPECTION

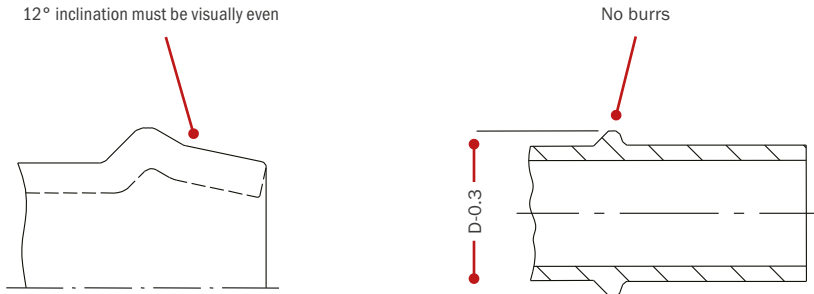

Checking using a gauge

Gates FS gauges make it easy to check the 24° angle and the 45° angle on a tube formed by the Gates machine FS 94.

Both angles are relevant for cutting ring connections according to ISO 8434-1, so that the connection is leakage-free and captive after assembly.

The appropriate tube outer diameter is shown on each gauge in order to rule out any confusion by the operator.

Always use the right gauge to check the angles and never use a gauge for a different tube outer diameter!

The forming contour is implied by the gauge, but this may not be used as a reference for optimal forming.

Gates FS gauges are only suitable for formings performed with the Gates FS machine and not for checking formings created by competitors' machines.

Function

Using the gauge, it is only possible to check the angles that are relevant for assembly and not the complete contour of the formed tube.

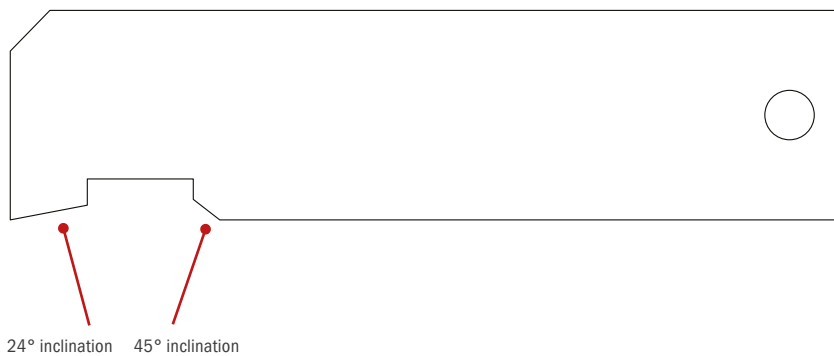

Measurement of 24° inclination

To do this, the gauge needs to be placed on the end of the formed tube (fig. 2). Please make sure that the handle of the gauge is resting firmly against the tube. Now slide the gauge backwards until the 24° angle is on the angle of the formed tube. If you can see a gap, the forming does not correspond to specifications and the tube may not be used. The length of the inclination on the gauge does not correspond to the length of the inclination on the formed tube. It just serves for measuring the angle.

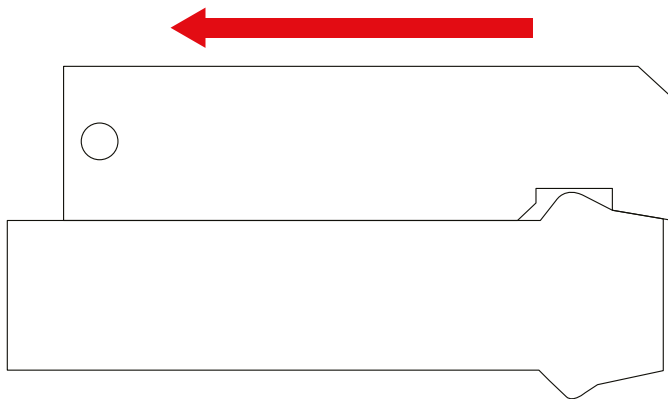

Measurement of 45° inclination

To do this, the gauge needs to be placed on the end of the formed tube (fig. 3). Please make sure that the handle of the gauge is resting firmly against the tube. Now slide the gauge forward until the gauge is on the 45° angle of the formed end. Again, if you can see a gap here, the forming is not correct and the tube may not be used. The length of the inclination on the gauge does not correspond to the length of the inclination on the formed tube. It just serves for measuring the angle.

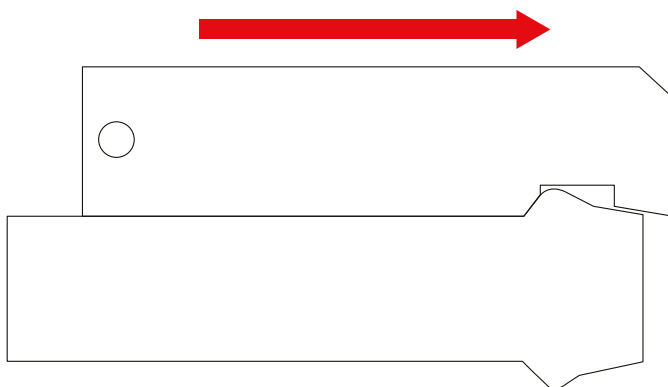

Guarantee

FS gauges serve only for checking the angles within the 24° and 45° inclination areas. In no case does the entire contour of the gauge allow a correct forming to be concluded. In order to do so, the operator of the machine should always perform a visual inspection in addition.

The FS gauges do not undergo any regular calibration by Gates, meaning that damaged gauges should be exchanged.

Gates Tube Fittings GmbH shall accept no liability for damages to property or personal injuries caused by improper or incorrect handling.

16. ASSEMBLY WITH FSR RING IN THE FITTING BODY

16.1. PRESSING THE FSR RING INTO THE FITTING BODY



The protruding rubber seal must be visible from the outside after assembly

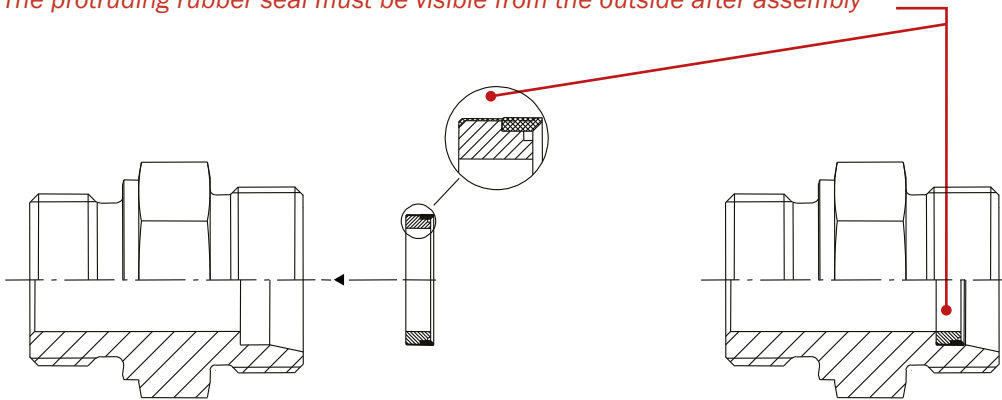

The ring cannot fall out of the borehole by itself due to its geometry. It is therefore captive.

16.2. PRESSING THE TUBE AGAINST THE 24° INCLINATION

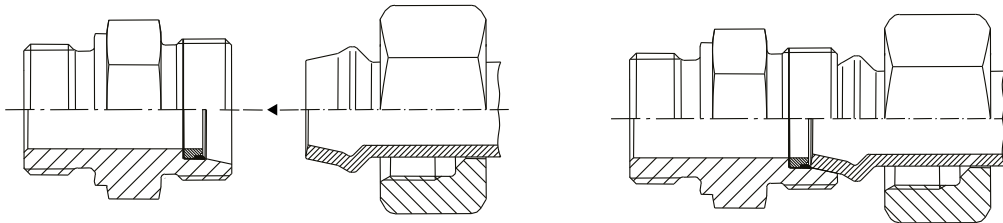

16.3. TIGHTENING THE NUT FINGER-TIGHT

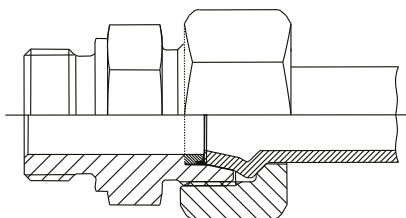

16.4. COMPLETING ASSEMBLY

Finish assembling the nut with a suitable key until a noticeable increase in force is felt (approx. 180°).

Following this assembly, the tube will be resting against the FSR ring and the soft seal will be completely chambered.

17. ASSEMBLY WITH FSSR RING IN THE FITTING BODY (FOR THIN TUBES)

17.1. SLIDING THE FSSR RING ONTO THE TUBE



IMPORTANT

The protruding rubber seal must be facing the front side of the tube

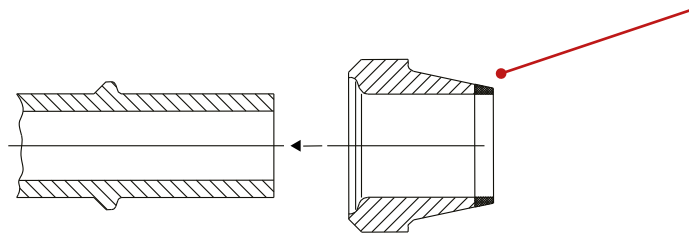

17.2. PRESSING THE TUBE INTO THE 24° CONNECTOR

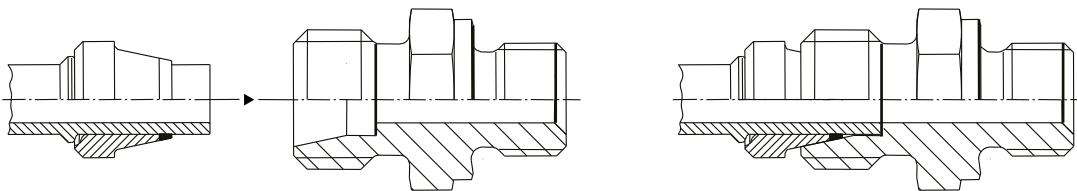

17.3. TIGHTENING THE NUT FINGER-TIGHT

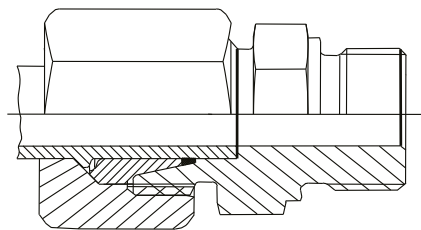

17.3. COMPLETING ASSEMBLY

Finish assembling the nut with a suitable key until a noticeable increase in force is felt (approx. 120°).

The ring will now be resting against the tube and the soft seal will be completely chambered.

18. TUBE LENGTH SHORTENING FOR STEEL

TUBE OUTSIDE	X1	X2
6x1	3.3	10.3
6x1.5	3.3	10.3
6x2	*	*
8x1	4.3	11.3
8x1.5	6.9	13.9
8x2	5.5	12.5
8x2.5	5.8	12.8
10x1	4.8	11.4
10x1.5	5.8	12.8
10x2	4.4	11.4
10x2.5	4.6	11.6
10x3	4.1	11.1
12x1	5.3	12.3
12x1.5	6.6	13.6
12x2	4.9	11.9
12x2.5	4.9	11.9
12x3	5.4	12.4
12x3.5	5.4	12.4
15x2	4.3	11.3
15x2.5	4.4	11.9
15x3	3.7	10.7
16x2	1.7	10.2
16x2.5	1.6	10.1
16x3	1.8	10.3
16x4	1.6	10.1
18x2	3.5	11.0
18x2.5	3.8	11.3
18x3	3.6	11.1
20x2.5	6.3	16.8
20x3	6.5	17.0
20x3.5	6.3	16.8
20x4	6.1	16.6
22x2	4.9	12.4
22x2.5	4.3	11.8
22x3	4.5	12.0
25x2.5	1.9	13.9

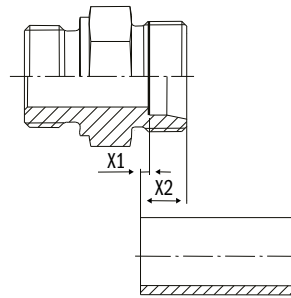

If the tube length from the tube stop is determined, the measurement X1 is to be added.
In the case of measurement from the connector end, the measurement X2 is to be added.

TUBE OUTSIDE	X1	X2
25x3	2.2	14.2
25x4	2.4	14.4
25x4.5	2.5	14.5
25x5	2.5	14.5
28x2.5	3.9	11.4
28x3	4.2	11.7
28x4	4.3	11.8
28x5	4.3	11.8
30x3	1.0	14.5
30x4	1.0	14.5
30x5	0.6	14.1
30x6	0.5	14.0
35x2.5	3.9	14.4
35x3	3.7	14.2
35x4	4.0	14.5
35x5	4.1	14.6
35x6	4.1	14.6
38x3	-1.4	14.6
38x4	-1.3	14.7
38x5	-1.3	14.7
38x6	-1.7	14.3
38x7	-2.1	13.9
42x3	4.2	15.2
42x3.5	*	*
42x4	4.7	15.7

Execution for thin-walled tubes

* Values available on request

19. TUBE LENGTH SHORTENING FOR HIGH GRADE STEEL

TUBE OUTSIDE	X1	X2
6x1	*	*
6x1.5	*	*
6x2	*	*
8x1	*	*
8x1.5	*	*
8x2	6.0	13.0
8x2.5	6.3	13.3
10x1	*	*
10x1.5	*	*
10x2	5.4	12.4
10x2.5	5.6	12.6
10x3	5.1	12.1
12x1	*	*
12x1.5	*	*
12x2	5.4	12.4
12x2.5	5.4	12.4
12x3	5.9	12.9
12x3.5	5.9	12.9
15x2	4.8	11.8
15x2.5	4.9	11.9
15x3	4.2	11.2
16x2	2.1	10.6
16x2.5	2.0	10.5
16x3	2.2	10.7
16x4	2.0	10.5
18x2	4.0	11.5
18x2.5	4.3	11.8
18x3	4.1	11.6
20x2.5	7.1	17.6
20x3	7.3	17.8
20x3.5	7.1	17.6
20x4	6.9	17.4
22x2	5.4	12.9
22x2.5	2.9	12.3
22x3	5.0	12.5
25x2.5	2.9	14.9

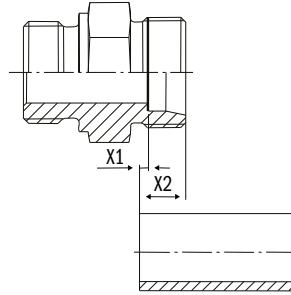

If the tube length from the tube stop is determined, the measurement X1 is to be added.
 In the case of measurement from the connector end, the measurement X2 is to be added.

TUBE OUTSIDE	X1	X2
25x3	3.2	15.2
25x4	3.4	15.4
25x4.5	3.5	15.5
25x5	3.5	15.5
28x2.5	4.9	12.4
28x3	5.2	12.7
28x4	5.3	12.8
28x5	5.3	12.8
30x3	2.0	15.5
30x4	2.0	15.5
30x5	1.6	15.1
35x2.5	4.8	15.3
35x3	4.6	15.1
35x4	4.9	15.4
35x5	5.0	15.5
35x6	5.0	15.5
38x3	-0.5	15.5
38x4	-1.0	15.0
38x5	-0.8	15.2
38x6	-0.7	15.3
42x3	5	16.0
42x3.5	*	*
42x4	5.5	16.5

Execution for thin-walled tubes

* Values available on request

20. MINIMUM STRAIGHT TUBE LENGTH

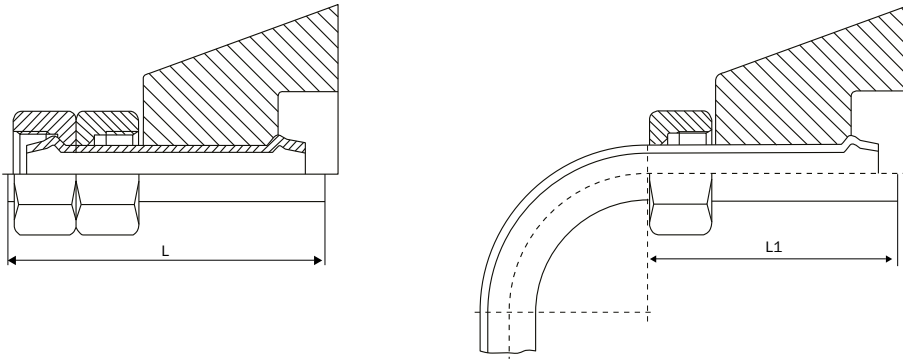

TUBE OUTSIDE DIAMETER [mm]	L* [mm]	L1* [mm]
6	90	70
8	90	70
10	90	70
12	90	70
15	90	70
16	100	75
18	95	70
20	115	85
22	100	75
25	135	105
28	120	95
30	140	110
35	140	110
38	150	115
42	140	110





DRIVEN BY POSSIBILITY™